

DRILLING

DRILLING PRODUCTS

D004E



DRILLING TOOLS



PRECISION
FOR SUCCESS

CHOOSE JAPAN'S NO. 1

MITSUBISHI
MITSUBISHI MATERIALS

www.mitsubishicarbide.com

HOW TO READ THE STANDARD OF DRILLING TOOLS

- How the pages are organised
- ① Organised according to the application for the drill.

PHOTO OF PRODUCT
PRODUCT TITLE
PRODUCT TYPE
PRODUCT SECTION

VIOLET DRILLS
VAPDS
Short, High precision

All drills except those with tolerances of 0.1mm and under dia. 20mm have a tolerance of ± 0.020 mm.

Highly efficient drilling and long tool life have been achieved with the newly developed Violet coating. (Standard drill depth: less than 3 times the drill diameter)

PRODUCT TYPE
PRODUCT SECTION

DRILLING (SOLID CARBIDE)
MPS, MSL

From 3-30 I'd hole depth.
High double margin type for accurate and reliable drilling.
All drills with through constant holes dia standard.

D1 Tolerance: 0.150-0.010, 0.200-0.010, 0.250-0.010, 0.300-0.010, 0.400-0.010
DIN type: 0.010, -0.002, -0.005, -0.013, -0.016

● Type A Double margin type
● Type B Standard margin type

MPS—SIL-DIN (I'd 3-5)
MPS—SIL-DIN-C (I'd 3-5)
MPS—L (I'd 8-30)

MSL (I'd 20-30)

Order Number	Dia. D1	Flute Length L1	Overall Length L2	Shank Dia. D2	Stock	Order Number	Dia. D1	Flute Length L1	Overall Length L2	Shank Dia. D2	Stock
VAPSD0050	0.5	3	50	3	●	VAPSD0088	0.88	6	50	3	●
D0051	0.51	3	50	3	●	D0089	0.89	6	50	3	●
D0052	0.52	3	50	3	●	D0090	0.9	6	50	3	●
D0053	0.53	3	50	3	●	D0091	0.91	6	50	3	●
D0054	0.54	3	50	3	●	D0092	0.92	6	50	3	●
D0055	0.55	3	50	3	●	D0093	0.93	6	50	3	●
D0056	0.56	4	50	3	●	D0094	0.94	6	50	3	●
D0057	0.57	4	50	3	●	D0095	0.95	6	50	3	●
D0058	0.58	4	50	3	●	D0096	0.96	6	50	3	●
D0059	0.59	4	50	3	●	D0097	0.97	6	50	3	●
D0060	0.6	5	50	3	●	D0098	0.98	6	50	3	●
D0061	0.61	5	50	3	●	D0099	0.99	6	50	3	●
D0062	0.62	5	50	3	●	D0100	1.0	6	50	3	●
D0063	0.63	5	50	3	●	D0101	1.01	6	50	3	●
D0064	0.64	5	50	3	●	D0102	1.02	6	50	3	●
D0065	0.65	5	50	3	●	D0103	1.03	6	50	3	●
D0066	0.66	5	50	3	●	D0104	1.04	6	50	3	●
D0067	0.67	5	50	3	●	D0105	1.05	6	50	3	●
D0068	0.68	5	50	3	●	D0106	1.06	6	50	3	●
D0069	0.69	5	50	3	●	D0107	1.07	8	55	3	●
D0070	0.7	5	50	3	●	D0108	1.08	8	55	3	●
D0071	0.71	5	50	3	●	D0109	1.09	8	55	3	●
D0072	0.72	5	50	3	●	D0110	1.1	8	55	3	●
D0073	0.73	5	50	3	●	D0111	1.11	8	55	3	●
D0074	0.74	5	50	3	●	D0112	1.12	8	55	3	●
D0075	0.75	5	50	3	●	D0113	1.13	8	55	3	●
D0076	0.76	5	50	3	●	D0114	1.14	8	55	3	●
D0077	0.77	5	50	3	●	D0115	1.15	8	55	3	●
D0078	0.78	5	50	3	●	D0116	1.16	8	55	3	●
D0079	0.79	5	50	3	●	D0117	1.17	8	55	3	●
D0080	0.8	5	50	3	●	D0118	1.18	8	55	3	●
D0081	0.81	5	50	3	●	D0119	1.19	8	55	3	●
D0082	0.82	5	50	3	●	D0120	1.2	8	55	3	●
D0083	0.83	5	50	3	●	D0121	1.21	8	55	3	●
D0084	0.84	5	50	3	●	D0122	1.22	8	55	3	●
D0085	0.85	5	50	3	●	D0123	1.23	8	55	3	●
D0086	0.86	6	50	3	●	D0124	1.24	8	55	3	●
D0087	0.87	6	50	3	●	D0125	1.25	8	55	3	●

● Inventory maintained. ● - Inventory maintained in Japan. CUTTING CONDITIONS: B093, B006

PRODUCT STANDARDS
indicates diameters, order numbers, stock status, number of flutes, dimensions and spare parts for the title product.

LEGEND FOR STOCK STATUS MARK
is shown on the page.

● To Order: For solid-carbide drills or brazed drills, please specify the order number and grade. For indexable type drills, please specify the order number for the drill. For indexable type drill inserts, please specify the insert number and insert grade.

DRILLING TOOLS



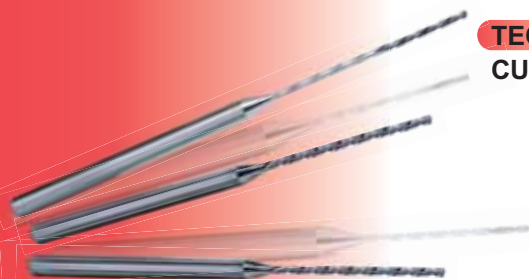







PRODUCT OVERVIEW	D002
DRILL NAVI	
<i>P</i> - Steel	D004
<i>M</i> - Stainless Steel	D008
<i>K</i> - Cast iron	D012
<i>S</i> - Special alloy	D016
<i>N</i> - Non ferrous alloy	D018
<i>H</i> - Hardened Material	D020
<i>X</i> - Drills for Special Applications	D021
PRODUCT CODE IDENTIFICATION	D022
SYMBOL DESCRIPTIONS	D023
SOLID CARBIDE	
MSE	[Micro Drill]..... D024
MINI-MWS	[Mini Drill with internal coolant] D030
MWE / MWS	[2 Margin Drill]..... D038
MWS	[2 Margin Super Long Drill] D048
MPS	[4 Margin & Super Long Drill]..... D059
MSL	[2 Margin Super Long Drill] D080
MGS	[Micro Gun Drill with internal coolant]..... D088
MNS	[4 Coolant hole Drill for Aluminium]..... D092
MAE / MAS	[High Precision Drill for Aluminium]..... D118
MHS	[Precision drill for hard materials]..... D126
VCHSM	[For Hard Material ~ 65HRC]..... D136
MHE	[Tailor made Drill for wheel hubs]..... D140
INDEXABLE DRILLS	
STAW	[Small Diameter Insert Drill]..... D146
TAW	[Insert Drill]..... D151
TAF	[Indexable Insert Drill] D164
BRAZED DRILLS	
BRS, BRM, BRK, BRA...	[Brazed Drill] D178
VIOLET DRILLS	
VAPDS	[HSS-Co short Drill for Steel]..... D185
VAPDM	[HSS-Co medium Drill for Steel]..... D192
VAPDS-SUS	[HSS-Co short Drill for Stainless Steel]..... D197
VAPDM-SUS	[HSS-Co medium Drill for Stainless Steel]..... D204
VEUS	[HSS long Drill for Stainless Steel]..... D211
VSD	[HSS long Drill for Stainless Steel]..... D214
VAPDS-CB	[HSS-Co Drill for Counter Boring] D217
TECHNICAL DATA	
CUTTING FORMULAE	D221



DRILL OVERVIEW

DRILLING DRILL OVERVIEW CHART

Cutting Mode	Size Range	Hole Depth	Product Code	Coolant	Shape	Coating	Work Material							Page		
							P	M	K	S	N	H	Dimensions	Cutting Conditions		
							Mild Steel	General Steel	Stainless Steel	Cast Iron	Special Alloy	Light Alloy			Hardened Steel	
Solid Carbide	φ0.10 ~ φ3.00	l/d 5 ~ 12	MSE	External	 MSP=Pilot Drill for MSE	VP	○	○	○	○	○	○			D024	D029
	φ0.5 ~ φ25.0	l/d 1 ~ 30	MWS	Internal		VP	○	○	○	○	○			D030	D056	
	φ3.0 ~ φ20.0	l/d 3 ~ 40	MPS/MSL	Internal		VP	○	○	○	○	○			D059	D078	
	φ3.0 ~ φ20.0	l/d 2 ~ 3	MWE	External		VP	○	○	○	○	○			D038	D056	
	φ3.0 ~ φ12.0	l/d 3 ~ 30	MHS	Internal		VP				○	○			D126	D134	
	φ2.5 ~ φ16.0	l/d ~ 3	VCHSM	External		VP				○	○			D136	D139	
	φ10.0 ~ φ18.0	l/d 5 ~ 12	MHE	External		VP	○	○	○	○				D140	D144	
	φ0.7 ~ φ3.0	l/d ~ 100	MGS	Internal			○	○	○	○	○	○			D088	D091
	φ3.0 ~ φ16.0	l/d ~ 3	MAE	External							○	○			D118	D125
	φ3.0 ~ φ16.0	l/d ~ 3	MAS	Internal							○	○			D118	D125
φ3.5 ~ φ14.0	l/d 3 ~ 30	MNS	Internal							○				D092	D116	
High Speed Steel	φ0.5 ~ φ13.0	l/d ~ 3	VAPDS	External		V	○	○	○	○	○			D185	D196	
	φ0.5 ~ φ32.0	l/d ~ 6	VAPDM			V	○	○	○	○	○			D192	D196	
	φ0.5 ~ φ13.0	l/d ~ 12	VSD			V	○	○	○	○	○			D214	D216	

Cutting Mode	Size Range	Hole Depth	Product Code	Coolant	Shape	Coating	Work Material							Page	
							P	M	K	S	N	H	Dimensions	Cutting Conditions	
							Mild Steel	General Steel	Stainless Steel	Cast Iron	Special Alloy	Light Alloy			Hardened Steel
High Speed Steel	φ0.5 ~ φ20.0	l/d ~ 5	VAPD5SUS	External		V	<input type="checkbox"/>	<input type="checkbox"/>	<input type="checkbox"/>	<input type="checkbox"/>	<input type="checkbox"/>	<input type="checkbox"/>	<input type="checkbox"/>	D197	D210
	φ0.5 ~ φ13.0	l/d ~ 12	VAPDMSUS			V	<input type="checkbox"/>	<input type="checkbox"/>	<input type="checkbox"/>	<input type="checkbox"/>	<input type="checkbox"/>	<input type="checkbox"/>	<input type="checkbox"/>	D204	D210
	φ1.0 ~ φ13.0	l/d ~ 10	VEUSM			V	<input type="checkbox"/>	<input type="checkbox"/>	<input type="checkbox"/>	<input type="checkbox"/>	<input type="checkbox"/>	<input type="checkbox"/>	<input type="checkbox"/>	D211	D213
	φ3.0 ~ φ20.0	l/d ~ 12	VAPD5CB			V	<input type="checkbox"/>	<input type="checkbox"/>	<input type="checkbox"/>	<input type="checkbox"/>	<input type="checkbox"/>	<input type="checkbox"/>	<input type="checkbox"/>	D219	D222
Indexable	φ10.0 ~ φ13.9	l/d 3 ~ 5	STAW	Internal		VP	<input type="checkbox"/>	<input type="checkbox"/>	<input type="checkbox"/>	<input type="checkbox"/>	<input type="checkbox"/>	<input type="checkbox"/>	<input type="checkbox"/>	D146	D150
	φ14.0 ~ φ30.4	l/d 3 ~ 8	TAW			VP	<input type="checkbox"/>	<input type="checkbox"/>	<input type="checkbox"/>	<input type="checkbox"/>	<input type="checkbox"/>	<input type="checkbox"/>	<input type="checkbox"/>	D151	D162
	φ12.0 ~ φ56.0	l/d ~ 4	TAF				<input type="checkbox"/>	<input type="checkbox"/>	<input type="checkbox"/>	<input type="checkbox"/>	<input type="checkbox"/>	<input type="checkbox"/>	<input type="checkbox"/>	D164	D174
Brazed	φ8.0 ~ φ40.0	l/d ~ 3	BRA	Internal		UP	<input type="checkbox"/>	<input type="checkbox"/>	<input type="checkbox"/>	<input type="checkbox"/>	<input type="checkbox"/>	<input type="checkbox"/>	<input type="checkbox"/>	D179	D184
	φ14.0 ~ φ30.0	l/d ~ 3	BR5			UP	<input type="checkbox"/>	<input type="checkbox"/>	<input type="checkbox"/>	<input type="checkbox"/>	<input type="checkbox"/>	<input type="checkbox"/>	<input type="checkbox"/>	D181	D184
	φ14.0 ~ φ30.0	l/d ~ 5	BRM			UP	<input type="checkbox"/>	<input type="checkbox"/>	<input type="checkbox"/>	<input type="checkbox"/>	<input type="checkbox"/>	<input type="checkbox"/>	<input type="checkbox"/>	D182	D184
	φ14.0 ~ φ30.0	l/d ~ 7	BRK			UP	<input type="checkbox"/>	<input type="checkbox"/>	<input type="checkbox"/>	<input type="checkbox"/>	<input type="checkbox"/>	<input type="checkbox"/>	<input type="checkbox"/>	D183	D184

















DRILL NAVI

DRILL SELECTION CHART

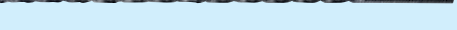
● Solid Carbide Drills









Size Range (mm)	Hole Depth (L/d)	Drill Tolerance	Drill Type/ Series	Shape	Internal Coolant	Coating	Shank Type			Page Number	
							(whistle notch) DIN 6535HE	(cylindrical) DIN 6535HA	(cylindrical) *	Dimensions	Cutting Conditions
φ3.0-φ20.0	2	h8	MWE...SA			VP			●	D038	D056
	3	h8	MWE...MA			VP			●	D038	D056
φ3.0-φ20.0	3	IT7	MPS...S-DIN (DIN6537)		●	VP	●	●		D062	D078
	5	IT7	MPS...L-DIN (DIN6537)		●	VP	●	●		D062	D078
φ3.0-φ14.0	8	h7	MPS...L8C		●	VP		●		D062	D078
	10	h7	MPS...L10C		●	VP		●		D062	D078
	12	h7	MPS...L12C		●	VP		●		D062	D078
φ3.0-φ14.0	15	h7	MPS...L15C		●	VP		●		D062	D078
	20	h7	MPS...L20C		●	VP		●		D062	D078
φ3.0-φ12.0	25	h7	MPS...L25C		●	VP		●		D062	D078
φ3.0-φ10.0	30	h7	MPS...L30C		●	VP		●		D062	D078
φ3.0-φ9.0	40	h7	MPS...L40C		●	VP		●		D062	D078
φ20.5-φ25.0	3	h8	MWS...MB		●	VP			●	D047	D057
	5	h8	MWS...LB		●	VP			●	D047	D057

*Note: Manufacturers Standard. For more details please refer to the product page.

DRILLING | DRILL SELECTION CHART - 1ST RECOMMENDATION FOR STEEL

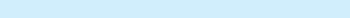

● Mini Solid Carbide Drills

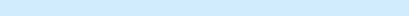
Size Range (mm)	Hole Depth (L/d)	Drill Tolerance	Drill Type/ Series	Shape	Internal Coolant	Coating	Shank Type			Page Number	
							(whistler notch) DIN 6535HE	(cylindrical) DIN 6535HA	(cylindrical) *	Dimensions	Cutting Conditions
φ0.10-φ3.0	5-12	0 ~ -0.009	MSE			VP			●	D026	D029
	-	-	MSP	 *Pilot Drill for MSE		VP			●	D028	D029
φ0.70-φ3.0	-100	0 ~ -0.005	MGS		●				*	D090	D091
φ0.5-φ2.95	1	0 ~ -0.014	MWS...SB		●	VP			●	D033	D056
φ0.5-φ2.9	5	*	MWS...LB		●	VP			●	D033	D056
	12	*	MWS...XB		●	VP			●	D033	D056
φ1.0-φ2.95	20	*	MWS.X20DB		●	VP			●	D035	D056
	25	*	MWS.X25DB		●	VP			●	D035	D056
	30	*	MWS.X30DB		●	VP			●	D035	D056

*Note: Manufacturers Standard. For more details please refer to the product page.









DRILL NAVI









DRILL SELECTION CHART

DRILLING | DRILL SELECTION CHART - 1ST RECOMMENDATION FOR STEEL

● HSS-Co Drills





Size Range (mm)	Hole Depth (L/d)	Drill Tolerance	Drill Type/ Series	Shape	Internal Coolant	Coating	Shank Type		Page Number	
							(whistle notch)	(cylindrical) *	Dimensions	Cutting Conditions
φ0.5-φ13.0	~6	*	VAPDS					●	D187	D196
φ0.5-φ32.0	~12	*	VAPDM					●	D192	D196
φ0.5-φ13.0	~12	*	VSD					●	D214	D216

● Brazed Drills



Size Range (mm)	Hole Depth (L/d)	Drill Tolerance	Drill Type/ Series	Shape	Internal Coolant	Coating	Shank Type		Page Number	
							(clamping face)	(cylindrical)	Dimensions	Cutting Conditions
φ8.0-φ40.0	3	h7	BRA		●		●		D179	D184
φ14.0-φ30.0	3	h7	BRS		●		●		D181	D184
	5	h8	BRM		●		●		D182	D184
	7	h8	BRK		●		●		D183	D184

*Note: Manufacturers Standard. For more details please refer to the product page.

● Insert Drills

Size Range (mm)	Hole Depth (L/d)	Drill Tolerance	Drill Type/ Series	Shape	Internal Coolant	Coating	Shank Type		Page Number	
							(clamping face)	(cylindrical) *	Dimensions	Cutting Conditions
φ10.0-φ13.9	3	h8	STAWSN		●	VP	●		D148	D150
	5	h8	STAWMN		●	VP	●		D148	D150
φ14.0-φ30.4	3	h7	TAWSN		●	VP	●		D154	D162
	5	h7	TAWMN		●	VP	●		D154	D162
	8	h7	TAWLN		●	VP	●		D154	D162

● Indexable Drills

Size Range (mm)	Hole Depth (L/d)	Drill Tolerance	Drill Type/ Series	Shape	Internal Coolant	Coating	Shank Type		Page Number	
							(clamping face)	(cylindrical) *	Dimensions	Cutting Conditions
φ12.0-φ56.0	2	~φ14.5 (0~-0.10)	TAFS		●	VP	●		D166	D174
	3		TAFM		●	VP	●		D166	D174
	4	≥φ15.0 (0~-0.20)	T AFL		●	VP	●		D166	D174

*Note: Manufacturers Standard. For more details please refer to the product page.













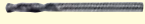



DRILL NAVI

DRILL SELECTION CHART

DRILL SELECTION CHART - 1ST RECOMMENDATION FOR STAINLESS STEEL









● Solid Carbide Drills

Size Range (mm)	Hole Depth (L/d)	Drill Tolerance	Drill Type/ Series	Shape	Internal Coolant	Coating	Shank Type			Page Number	
							(Whistle notch) DIN 6535HE	(Cylindrical) DIN 6535HA	(Cylindrical) *	Dimensions	Cutting Conditions
φ3.0-φ20.0	2	h8	MWE...SA			VP			●	D038	D056
	3	h8	MWE...MA			VP			●	D038	D056
φ3.0-φ20.0	3	IT7	MPS...S-DIN (DIN6537)		●	VP	●	●		D062	D078
	5	IT7	MPS...L-DIN (DIN6537)		●	VP	●	●		D062	D078
φ3.0-φ14.0	8	h7	MPS...L8C		●	VP		●		D062	D078
	10	h7	MPS...L10C		●	VP		●		D062	D078
	12	h7	MPS...L12C		●	VP		●		D062	D078
φ3.0-φ14.0	15	h7	MPS...L15C		●	VP		●		D062	D078
	20	h7	MSLL20C		●	VP		●		D082	D086
φ3.0-φ12.0	25	h7	MSLL25C		●	VP		●		D082	D086
φ3.0-φ10.0	30	h7	MSLL30C		●	VP		●		D082	D086
φ3.0-φ9.0	40	h7	MPS...L40C		●	VP		●		D062	D078
φ20.5-φ25.0	3	h8	MWS...MB		●	VP			●	D047	D057
	5	h8	MWS...LB		●	VP			●	D047	D057

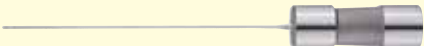
*Note: Manufacturers Standard. For more details please refer to the product page.

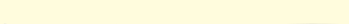

● Mini Solid Carbide Drills

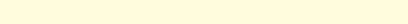
Size Range (mm)	Hole Depth (L/d)	Drill Tolerance	Drill Type/ Series	Shape	Internal Coolant	Coating	Shank Type			Page Number	
							(whistle notch) DIN 6535HE	(cylindrical) DIN 6535HA	(cylindrical) *	Dimensions	Cutting Conditions
φ0.10-φ3.0	5-12	0 ~ -0.009	MSE			VP			●	D026	D029
	-	-	MSP	 *Pilot Drill for MSE		VP			●	D028	D029
φ0.70-φ3.0	-100	0 ~ -0.005	MGS		●				*	D090	D091
φ0.5-φ2.95	1	0 ~ -0.014	MWS...SB		●	VP			●	D033	D056
φ0.5-φ2.9	5	*	MWS...LB		●	VP			●	D033	D056
	12	*	MWS...XB		●	VP			●	D033	D056
φ1.0-φ2.95	20	*	MWS...X20DB		●	VP			●	D035	D056
	25	*	MWS...X25DB		●	VP			●	D035	D056
	30	*	MWS...X30DB		●	VP			●	D035	D056

*Note: Manufacturers Standard. For more details please refer to the product page.





DRILL NAVI





DRILL SELECTION CHART

DRILL SELECTION CHART - 1ST RECOMMENDATION FOR STAINLESS STEEL

● HSS-Co Drills

Size Range (mm)	Hole Depth (L/d)	Drill Tolerance	Drill Type/ Series	Shape	Internal Coolant	Coating	Shank Type		Page Number	
							(whistle notch)	(cylindrical) *	Dimensions	Cutting Conditions
φ0.5-φ20.0	~5	*	VAPDS-SUS			V		●	D198	D210
φ0.5-φ13.0	~12	*	VAPDM-SUS			V		●	D204	D210
φ1.0-φ13.0	~10	*	VEUSM			V		●	D211	D213

● Brazed Drills



Size Range (mm)	Hole Depth (L/d)	Drill Tolerance	Drill Type/ Series	Shape	Internal Coolant	Coating	Shank Type		Page Number	
							(clamping face)	(cylindrical)	Dimensions	Cutting Conditions
φ8.0-φ40.0	3	h7	BRA		●	UP	●		D179	D184
φ14.0-φ30.0	3	h7	BRS		●	UP	●		D181	D184
	5	h8	BRM		●	UP	●		D182	D184
	7	h8	BRK		●	UP	●		D183	D184

*Note: Manufacturers Standard. For more details please refer to the product page.





● Indexable Drills

Size Range (mm)	Hole Depth (L/d)	Drill Tolerance	Drill Type/ Series	Shape	Internal Coolant	Coating	Shank Type		Page Number	
							(clamping face)	(cylindrical) *	Dimensions	Cutting Conditions
φ12.0-φ56.0	2	~φ14.5 (0~-0.10) ≥φ15.0 (0~-0.20)	TAF5		●	VP	●		D166	D174
	3		TAFM		●	VP	●		D166	D174
	4		T AFL		●	VP	●		D166	D174

*Note: Manufacturers Standard. For more details please refer to the product page.



















DRILL NAVI

DRILL SELECTION CHART

● Solid Carbide Drills

DRILLING | DRILL SELECTION CHART - 1ST RECOMMENDATION FOR CAST IRON

Size Range (mm)	Hole Depth (L/d)	Drill Tolerance	Drill Type/ Series	Shape	Internal Coolant	Coating	Shank Type			Page Number	
							(whistle notch) DIN 6535HE	(cylindrical) DIN 6535HA	(cylindrical) *	Dimensions	Cutting Conditions
φ3.0-φ20.0	2	h8	MWE..SA			VP			●	D038	D056
	3	h8	MWE..MA			VP			●	D038	D056
φ3.0-φ20.0	3	IT7	MPS..S-DIN (DIN6537)		●	VP	●	●		D062	D078
	5	IT7	MPS..L-DIN (DIN6537)		●	VP	●	●		D062	D078
φ3.0-φ14.0	8	h7	MPS..L8C		●	VP		●		D062	D078
	10	h7	MPS..L10C		●	VP		●		D062	D078
	12	h7	MPS..L12C		●	VP		●		D062	D078
φ3.0-φ14.0	15	h7	MPS..L15C		●	VP		●		D062	D078
	20	h7	MPS..L20C		●	VP		●		D062	D078
φ3.0-φ12.0	25	h7	MPS..L25C		●	VP		●		D062	D078
φ3.0-φ10.0	30	h7	MPS..L30C		●	VP		●		D062	D078
φ3.0-φ9.0	40	h7	MPS..L40C		●	VP		●		D062	D078
φ20.5-φ25.0	3	h8	MWS..MB		●	VP			●	D047	D057
	5	h8	MWS..LB		●	VP			●	D047	D057

*Note: Manufacturers Standard. For more details please refer to the product page.

● Mini Solid Carbide Drills

Size Range (mm)	Hole Depth (L/d)	Drill Tolerance	Drill Type/ Series	Shape	Internal Coolant	Coating	Shank Type			Page Number	
							(whistle notch) DIN 6535HE	(cylindrical) DIN 6535HA	(cylindrical) *	Dimensions	Cutting Conditions
φ0.10-φ3.0	5-12	0 ~ -0.009	MSE			VP			●	D026	D029
	-	-	MSP	 *Pilot Drill for MSE		VP			●	D028	D029
φ0.70-φ3.0	-100	0 ~ -0.005	MGS		●				*	D090	D091
φ0.5-φ2.95	1	0 ~ -0.014	MWS...SB		●	VP			●	D033	D056
φ0.5-φ2.9	5	*	MWS...LB		●	VP			●	D033	D056
	12	*	MWS...XB		●	VP			●	D033	D056
φ1.0-φ2.95	20	*	MWS...X20DB		●	VP			●	D035	D056
	25	*	MWS...X25DB		●	VP			●	D035	D056
	30	*	MWS...X30DB		●	VP			●	D035	D056

*Note: Manufacturers Standard. For more details please refer to the product page.





DRILL NAVI





DRILL SELECTION CHART

DRILLING DRILL SELECTION CHART - 1ST RECOMMENDATION FOR CAST IRON

● HSS-Co Drills





Size Range (mm)	Hole Depth (L/d)	Drill Tolerance	Drill Type/ Series	Shape	Internal Coolant	Coating	Shank Type		Page Number	
							(clamping face)	(cylindrical) *	Dimensions	Cutting Conditions
φ0.5-φ13.0	~6	*	VAPDS			V		●	D185	D194
φ0.5-φ32.0	~12	*	VAPDM			V		●	D190	D194
φ0.5-φ13.0	~12	*	VSD			V		●	D212	D214

● Brazed Drills



Size Range (mm)	Hole Depth (L/d)	Drill Tolerance	Drill Type/ Series	Shape	Internal Coolant	Coating	Shank Type		Page Number	
							(clamping face)	(cylindrical) *	Dimensions	Cutting Conditions
φ8.0-φ40.0	3	h7	BRA		●	UP	●		D179	D184
φ14.0-φ30.0	3	h7	BRS		●	UP	●		D181	D184
	5	h8	BRM		●	UP	●		D182	D184
	7	h8	BRK		●	UP	●		D183	D184

*Note: Manufacturers Standard. For more details please refer to the product page.

● Insert Drills

Size Range (mm)	Hole Depth (L/d)	Drill Tolerance	Drill Type/ Series	Shape	Internal Coolant	Coating	Shank Type		Page Number	
							(whistle notch)	(cylindrical) *	Dimensions	Cutting Conditions
φ10.0-φ13.9	3	h8	STAWSN		●	VP	●		D148	D150
	5	h8	STAWMN		●	VP	●		D148	D150
φ14.0-φ30.4	3	h7	TAWSN		●	VP	●		D154	D162
	5	h7	TAWMN		●	VP	●		D154	D162
	8	h7	TAWLN		●	VP	●		D154	D162

● Indexable Drills

Size Range (mm)	Hole Depth (L/d)	Drill Tolerance	Drill Type/ Series	Shape	Internal Coolant	Coating	Shank Type		Page Number	
							(whistle notch)	(cylindrical) *	Dimensions	Cutting Conditions
φ12.0-φ56.0	2	~φ14.5 (0~0.10) ≥φ15.0 (0~0.20)	TAFS		●	VP	●		D166	D174
	3		TAFM		●	VP	●		D166	D174
	4		T AFL		●	VP	●		D166	D174













*Note: Manufacturers Standard. For more details please refer to the product page.



DRILL NAVI

DRILL SELECTION CHART

DRILLING DRILL SELECTION CHART - 1ST RECOMMENDATION SUPER ALLOYS

Size Range (mm)	Hole Depth (L/d)	Drill Tolerance	Drill Type/ Series	Shape	Internal Coolant	Coating	Shank Type			Page Number	
							(Whistle notch) DIN 6535HE	(Cylindrical) DIN 6535HA	(Cylindrical) *	Dimensions	Cutting Conditions
φ3.0-φ20.0	2	h8	MWE...SA			VP			●	D038	D056
	3	h8	MWE...MA			VP			●	D038	D056
φ3.0-φ25.0	3	h8	MWS...MB		●	VP			●	D038	D057
	5	h8	MWS...LB		●	VP			●	D038	D057
φ3.0-φ16.0	8	h7	MWS...X8DB		●	VP			●	D038	D057
φ3.0-φ14.0	10	h7	MWS...X10DB		●	VP			●	D049	D057
	15	h7	MWS...X15DB		●	VP			●	D049	D057
	20	h7	MSL...L20C		●	VP		●		D049	D057
φ3.0-φ12.0	25	h7	MSL...L25C		●	VP		●		D049	D057
φ3.0-φ10.0	30	h7	MSL...L30C		●	VP		●		D049	D057
φ20.5-φ25.0	3	h8	MWS...MB		●	VP			●	D047	D057
	5	h8	MWS...LB		●	VP			●	D047	D057

*Note: Manufacturers Standard. For more details please refer to the product page.

● Mini Solid Carbide Drills

Size Range (mm)	Hole Depth (L/d)	Drill Tolerance	Drill Type/ Series	Shape	Internal Coolant	Coating	Shank Type			Page Number	
							(whistle notch) DIN 6535HE	(cilindrico) DIN 6535HA	(cilindrico) *	Dimensions	Cutting Conditions
φ0.10-φ3.0	5-12	0 ~ -0.009	MSE			VP			●	D026	D029
	-	-	MSP	 *Pilot Drill for MSE		VP			●	D028	D029
φ0.70-φ3.0	-100	0 ~ -0.005	MGS		●				*	D090	D091
φ0.5-φ2.95	1	0 ~ -0.014	MWS...SB		●	VP			●	D033	D056
φ0.5-φ2.9	5	*	MWS...LB		●	VP			●	D033	D056
	12	*	MWS...XB		●	VP			●	D033	D056
φ1.0-φ2.95	20	*	MWS...X20DB		●	VP			●	D035	D056
	25	*	MWS...X25DB		●	VP			●	D035	D056
	30	*	MWS...X30DB		●	VP			●	D035	D056

● HSS-Co Drills

Size Range (mm)	Hole Depth (L/d)	Drill Tolerance	Drill Type/ Series	Shape	Internal Coolant	Coating	Shank Type		Page Number		
							(whistle notch)	(cilindrico) *	Dimensions	Cutting Conditions	
φ0.5-φ13.0	~6	*	VAPDS			V			●	D187	D196
φ0.5-φ32.0	~12	*	VAPDM			V			●	D192	D196

*Note: Manufacturers Standard. For more details please refer to the product page.

















DRILL NAVI

DRILL SELECTION CHART

DRILL SELECTION CHART - 1ST RECOMMENDATION FOR NON FERROUS ALLOYS

● Solid Carbide Drills

Size Range (mm)	Hole Depth (L/d)	Drill Tolerance	Drill Type/ Series	Shape	Internal Coolant	Coating	Shank Type			Page Number	
							(whistle notch) DIN 6535HE	(cylindrical) DIN 6535HA	(cylindrical) *	Dimensions	Cutting Conditions
φ3.0-φ16.0	3	0~ +0.005	MAE..MB			-			●	D120	D125
	3	0~ +0.005	MAS..MB		●	-			●	D120	D125
	6	0~ +0.005	MAS..LB		●	-			●	D120	D125
φ3.0-φ14.0	3	IT7	MNS..S-DIN (DIN6537)		●	-	●	●		D094	D116
	5	IT7	MNS..L-DIN (DIN6537)		●	-	●	●		D094	D116
φ3.0-φ14.0	8	h8	MNS..L8C		●	-		●		D094	D116
	10	h8	MNS..L10C		●	-		●		D094	D116
	12	h8	MNS..L12C		●	-		●		D094	D116
	15	h8	MNS..L15C		●	-		●		D094	D116
φ3.0-φ14.0	20	h8	MNS..L20C		●	-		●		D094	D166
φ3.0-φ12.0	25	h8	MNS..L25C		●	-		●		D094	D116
φ3.0-φ10.0	30	h8	MNS..L30C		●	-		●		D094	D116

*Note: Manufacturers Standard. For more details please refer to the product page.

● Mini Solid Carbide Drills

Size Range (mm)	Hole Depth (L/d)	Drill Tolerance	Drill Type/ Series	Shape	Internal Coolant	Coating	Shank Type			Page Number	
							(whistle notch) DIN 6535HE	(cylindrical) DIN 6535HA	(cylindrical) *	Dimensions	Cutting Conditions
φ0.10-φ3.0	5-12	0 ~ -0.009	MSE			VP			●	D026	D029
	-	-	MSP	 *Pilot Drill for MSE		VP			●	D028	D029
φ0.70-φ3.0	-100	0 ~ -0.005	MGS		●				*	D090	D091
φ0.5-φ2.95	1	0 ~ -0.014	MWS...SB		●	VP			●	D033	D056
φ0.5-φ2.9	5	*	MWS...LB		●	VP			●	D033	D056
	12	*	MWS...XB		●	VP			●	D033	D033
φ1.0-φ2.95	20	*	MWS...X20DB		●	VP			●	D035	D056
	25	*	MWS...X25DB		●	VP			●	D035	D056
	30	*	MWS...X30DB		●	VP			●	D035	D056

● HSS-Co Drills

Size Range (mm)	Hole Depth (L/d)	Drill Tolerance	Drill Type/ Series	Shape	Internal Coolant	Coating	Shank Type		Page Number		
							(whistle notch)	(cylindrical) *	Dimensions	Cutting Conditions	
φ0.5-φ20.0	~5	*	VAPDS-SUS			V			●	D198	D210
φ0.5-φ13.0	~12	*	VAPDM-SUS			V			●	D204	D210

*Note: Manufacturers Standard. For more details please refer to the product page.





DRILL NAVI

DRILL SELECTION CHART

DRILL SELECTION CHART - 1ST RECOMMENDATION FOR HARDENED MATERIALS

● Solid Carbide Drills

Size Range (mm)	Hole Depth (L/d)	Drill Tolerance	Drill Type/ Series	Shape	Internal Coolant	Coating	Shank Type			Page Number	
							(whistlenotch) DIN 6535HE	(cylindrical) DIN 6535HA	(cylindrical) *	Dimensions	Cutting Conditions
φ2.5-φ16.0	3	h8	VCHSM			VC			●	D138	D139
φ3.0-φ12.0	1-30	IT7	MHS		●	VP			●	D129	D134

*Note: Manufacturers Standard. For more details please refer to the product page.





● Solid carbide drill for wheel hubs

Size Range (mm)	Hole Depth (L/d)	Drill Tolerance	Drill Type/ Series	Shape	Internal Coolant	Coating	Shank Type			Page Number	
							(whistle notch) DIN 6535HE	(cylindrical) DIN 6535HA	(cylindrical) *	Dimensions	Cutting Conditions
φ10.0-φ18.0	5-12	*	MHE			VP			●	D141	D144

● HSS-Co Drill for counter boring

Size Range (mm)	Hole Depth (L/d)	Drill Tolerance	Drill Type/ Series	Shape	Internal Coolant	Coating	Shank Type			Page Number	
							(whistle notch)	(cylindrical) *		Dimensions	Cutting Conditions
φ3.0-φ14.0	~12	*	VAPDS-CB			V			●	D217	D220

● Insertable Drill for Rivet holes

Size Range (mm)	Hole Depth (L/d)	Drill Tolerance	Drill Type/ Series	Shape	Internal Coolant	Coating	Shank Type			Page Number	
							(whistle notch)	(cylindrical) *		Dimensions	Cutting Conditions
φ24.5-φ26.7	3	h8	TAWSB		●	VP	●			D163	D163
	5	h8	TAWMB		●	VP	●			D163	D163

*Note: Manufacturers Standard. For more details please refer to the product page.

PRODUCT CODE IDENTIFICATION

PRODUCT CODE OF DRILLS

MW

E

0300

S

A

Drill Product Name	Coolant Type	Diameter	L/D	Shank Diameter Type
MW : MWE/MWS Drills MS : MSL Drills MP : MPS Drills MA : MAE/MAS Drills MN : MNS Drills MH : MHS Drills	E : External Coolant S : Internal Coolant L : Internal Coolant	Ex. 0300 → ϕ 3.0 0050 → ϕ 0.5	S : 1D / 2D M : 3D L : 5D (MAE / MAS Type = 6D) X : 8D / 12D LOCC : 8D, 10D, 12D, 15D etc.	A : Shank with the same diameter as the drill B : Shank with fixed diameter

*Exceptions partly included.

VA

PD

S

SUS

D0300

Drill Product Name	Applications	Flute Length	Work Material	Diameter
VA : Violet coated precision drills (High Grade, High Speed Steel) VE : Violet coated drills (Cobalt High-Speed Steel) V : Violet drills	SD : General purpose straight drill PD : For high precision machining	S : Short M : Medium	SUS : For stainless steel	Ex. D0300 → ϕ 3.0 D0050 → ϕ 0.5

*Exceptions partly included.

SYMBOL DESCRIPTIONS

Tool material



Ultra micro grain carbide
Ultra micro grain carbide is used as the substrate material.



High grade high alloy HSS
High grade high alloy HSS is used as the substrate material.



Cobalt high speed steel
Cobalt high speed steel is used as the substrate material.



High speed steel
High speed steel is used as the substrate material.

Web thinning



X web thinning
X web thinning is used at the drill point.



XR web thinning
XR web thinning is used at the drill point.

Recommendations

ISO Workpiece Classifications

✓ 1st recommendation ✓ 2nd recommendation

P ✓	M ✓	K ✓	S ✓	N	H
------------	------------	------------	------------	----------	----------

Coating



MIRACLE Coating
The original MIRACLE (Al,Ti)N coating.
Also suitable for dry cutting.



UP Coating



VIOLET Coating

Tolerances



Diameter tolerance
Indicates the diameter tolerance of the drill.

Angle and sharp corner edge



Point angle
Indicates the drill point angle at the tip.



MSE

Solid Carbide micro drills for highly efficient,
precise, stable micro drilling.

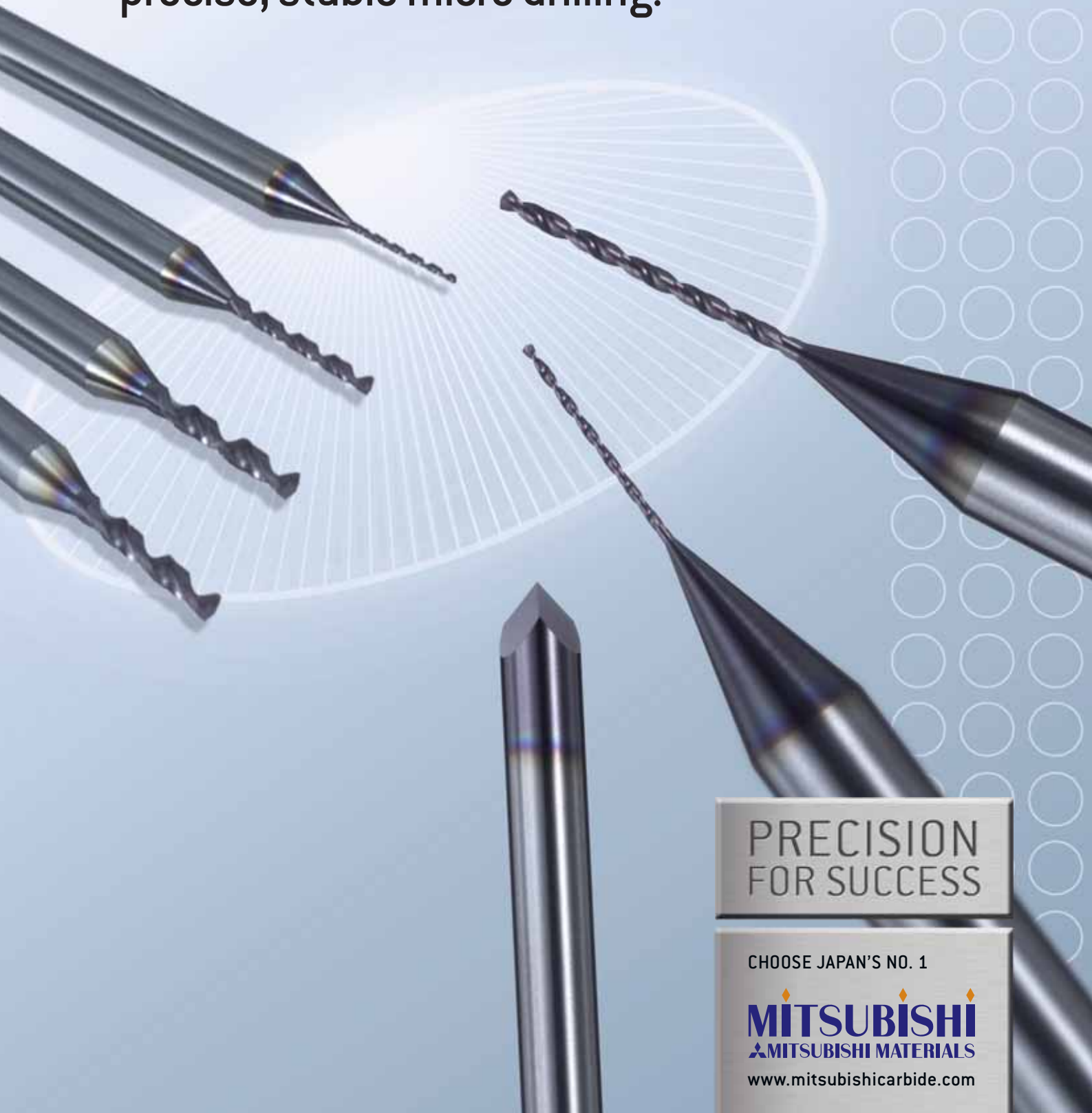

PRECISION
FOR SUCCESS

CHOOSE JAPAN'S NO. 1

MITSUBISHI
MITSUBISHI MATERIALS

www.mitsubishicarbide.com

MSE-Drill

Features

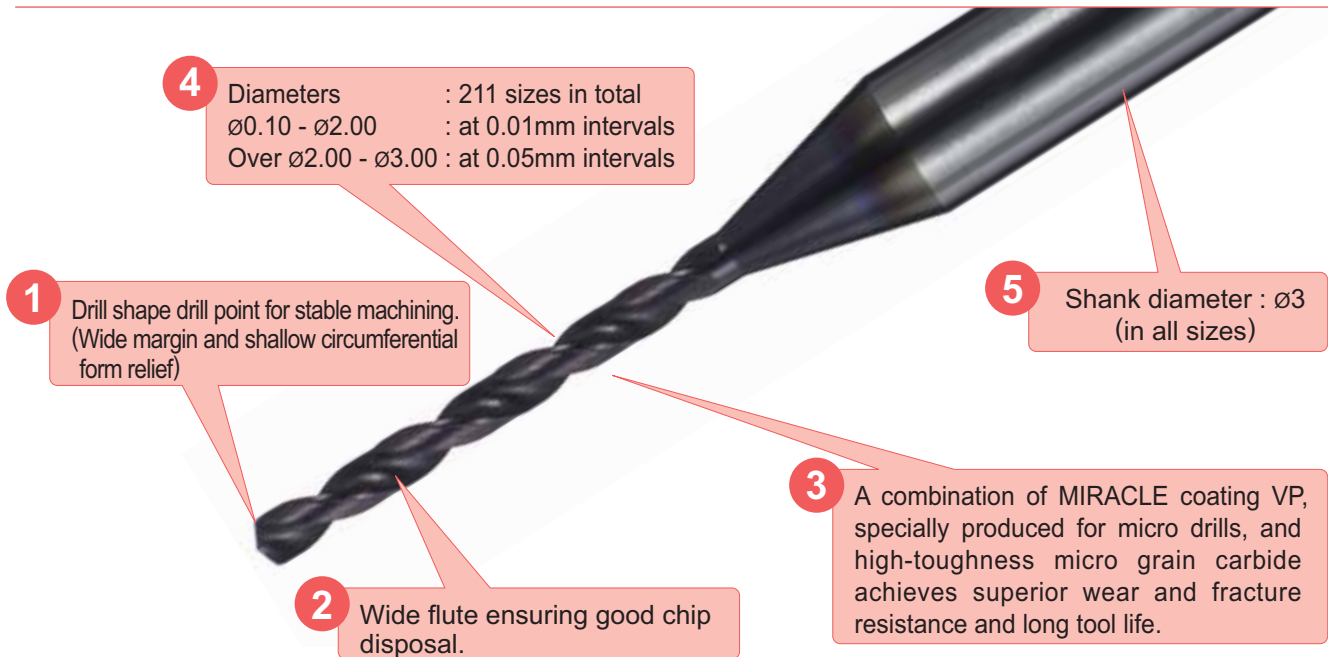

Cutting performance

● Tool life evaluation (stainless steel drilling)

Superior resistance to welding, wear and fracture. Long tool life.

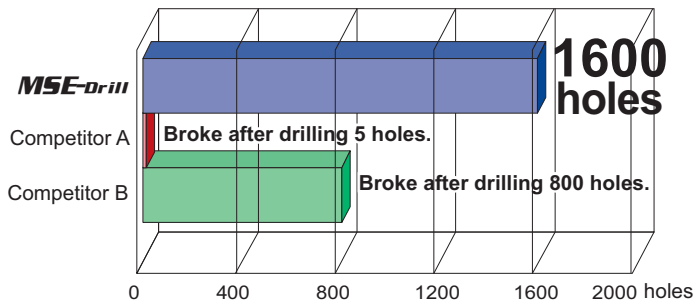

<Cutting conditions>
 Tool : MSE0050SB
 Workpiece : SUS304
 Cutting speed : 9.4m/min (6,000min⁻¹)
 Feed : 0.015mm/rev (90mm/min)
 Hole depth : 5.0mm Blind hole
 Steps : 0.15mm
 Coolant : Water soluble emulsion
 Machine : Machining centre

● Chips disposal (aluminum alloy drilling)

Wide flute prevents chip jamming.

Stepped drilling test : We increased a "step"-distance of a drill being reversed-by 0.05mm every 100 holes drilling.

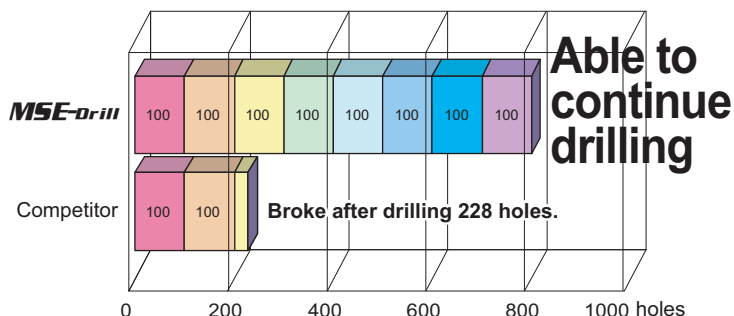

<Cutting conditions>
 Tool : MSE0050SB
 Workpiece : A7075P
 Cutting speed : 25m/min (16,000min⁻¹)
 Feed : 0.075mm/rev (1,200mm/min)
 Hole depth : 5.0mm Blind hole
 Coolant : Water soluble emulsion
 Machine : Machining centre

DRILLING (SOLID CARBIDE)

MSE

- Wide flute for preventing chip jamming.
- Stable, small diameter machining.



P	M	K	S	N	H
✓	✓	✓	✓	✓	✓

D1	0.10 ≤ D1 ≤ 3.00
Tolerance	0 -0.009

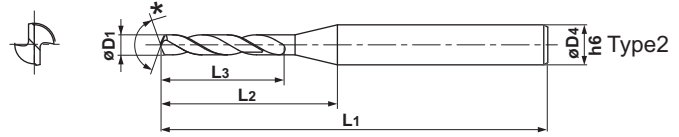
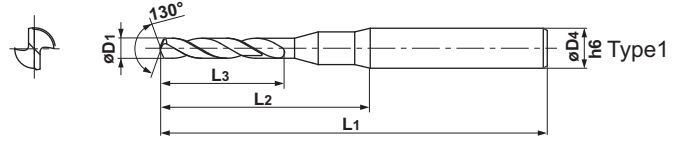

*Drill Dia. φ 0.30—1.59 : 130°
φ 1.60—2.50 : 140°

DRILLING MSE DRILLS

∅ 0.10 ~ 0.77

Drill Dia. D1 (mm)	Coolant (Int./Ext.)	Stock		Order Number	Dimensions (mm)				Type
		VP20MF	VP15TF		L3	L2	L1	D4	
0.10	Ext.	★		MSE0010SB	1.2	9.7	38	3	1
0.11	Ext.	★		0011SB	1.2	9.7	38	3	1
0.12	Ext.	★		0012SB	1.4	9.7	38	3	1
0.13	Ext.	★		0013SB	1.4	9.7	38	3	1
0.14	Ext.	★		0014SB	2	9.7	38	3	1
0.15	Ext.	●		0015SB	2	9.7	38	3	1
0.16	Ext.	★		0016SB	2	9.7	38	3	1
0.17	Ext.	★		0017SB	2	9.7	38	3	1
0.18	Ext.	★		0018SB	2	9.7	38	3	1
0.19	Ext.	★		0019SB	2	9.7	38	3	1
0.20	Ext.	★		0020SB	2.5	9.7	38	3	1
0.21	Ext.	★		0021SB	2.5	9.7	38	3	1
0.22	Ext.	★		0022SB	2.5	9.7	38	3	1
0.23	Ext.	★		0023SB	2.5	9.7	38	3	1
0.24	Ext.	★		0024SB	3	9.7	38	3	1
0.25	Ext.	★		0025SB	3	9.7	38	3	1
0.26	Ext.	★		0026SB	3	9.7	38	3	1
0.27	Ext.	★		0027SB	3	9.7	38	3	1
0.28	Ext.	★		0028SB	3	9.7	38	3	1
0.29	Ext.	★		0029SB	3	9.7	38	3	1
0.30	Ext.		★	0030SB	5	10.2	38	3	2
0.31	Ext.		★	0031SB	5	10.2	38	3	2
0.32	Ext.		★	0032SB	5	10.2	38	3	2
0.33	Ext.		★	0033SB	5	10.2	38	3	2
0.34	Ext.		★	0034SB	6	11.2	38	3	2
0.35	Ext.		★	0035SB	6	11.1	38	3	2
0.36	Ext.		★	0036SB	6	11.1	38	3	2
0.37	Ext.		★	0037SB	6	11.1	38	3	2
0.38	Ext.		★	0038SB	6	11.1	38	3	2
0.39	Ext.		★	0039SB	6	11.1	38	3	2
0.40	Ext.		●	0040SB	7	12.1	38	3	2
0.41	Ext.		★	0041SB	7	12.0	38	3	2
0.42	Ext.		★	0042SB	7	12.0	38	3	2
0.43	Ext.		★	0043SB	7	12.0	38	3	2

Drill Dia. D1 (mm)	Coolant (Int./Ext.)	Stock		Order Number	Dimensions (mm)				Type
		VP20MF	VP15TF		L3	L2	L1	D4	
0.44	Ext.		★	MSE0044SB	7	12.0	38	3	2
0.45	Ext.		★	0045SB	7	12.0	38	3	2
0.46	Ext.		★	0046SB	7	11.9	38	3	2
0.47	Ext.		★	0047SB	7	11.9	38	3	2
0.48	Ext.		★	0048SB	7	11.9	38	3	2
0.49	Ext.		★	0049SB	7	11.9	38	3	2
0.50	Ext.		●	0050SB	7	11.9	38	3	2
0.51	Ext.		★	0051SB	7	11.8	38	3	2
0.52	Ext.		★	0052SB	7	11.8	38	3	2
0.53	Ext.		★	0053SB	7	11.8	38	3	2
0.54	Ext.		★	0054SB	7	11.8	38	3	2
0.55	Ext.		●	0055SB	7	11.8	38	3	2
0.56	Ext.		★	0056SB	7	11.8	38	3	2
0.57	Ext.		★	0057SB	7	11.7	38	3	2
0.58	Ext.		★	0058SB	7	11.7	38	3	2
0.59	Ext.		★	0059SB	7	11.7	38	3	2
0.60	Ext.		●	0060SB	7	11.7	38	3	2
0.61	Ext.		★	0061SB	7	11.7	38	3	2
0.62	Ext.		★	0062SB	7	11.6	38	3	2
0.63	Ext.		★	0063SB	7	11.6	38	3	2
0.64	Ext.		★	0064SB	7	11.6	38	3	2
0.65	Ext.		●	0065SB	7	11.6	38	3	2
0.66	Ext.		★	0066SB	7	11.6	38	3	2
0.67	Ext.		★	0067SB	7	11.5	38	3	2
0.68	Ext.		★	0068SB	7	11.5	38	3	2
0.69	Ext.		★	0069SB	7	11.5	38	3	2
0.70	Ext.		●	0070SB	8	12.5	38	3	2
0.71	Ext.		★	0071SB	8	12.5	38	3	2
0.72	Ext.		★	0072SB	8	12.5	38	3	2
0.73	Ext.		★	0073SB	8	12.4	38	3	2
0.74	Ext.		★	0074SB	8	12.4	38	3	2
0.75	Ext.		●	0075SB	8	12.4	38	3	2
0.76	Ext.		★	0076SB	8	12.4	38	3	2
0.77	Ext.		★	0077SB	8	12.4	38	3	2

(Note) Please contact us for any geometry that is not in this catalogue (e.g. different diameters and lengths can be made to order).

- : Stock Standard.
- ★ : Stock Standard in Japan.
- : Non stock, produced to order only.

Drill Dia. D1 (mm)	Coolant (Int./Ext.)	Stock		Order Number	Dimensions (mm)				Type
		VP20MF	VP15TF		L3	L2	L1	D4	
0.78	Ext.	★		MSE0078SB	8	12.3	38	3	2
0.79	Ext.	★		0079SB	8	12.3	38	3	2
0.80	Ext.	●		0080SB	10	14.3	38	3	2
0.81	Ext.	★		0081SB	10	14.3	38	3	2
0.82	Ext.	★		0082SB	10	14.3	38	3	2
0.83	Ext.	★		0083SB	10	14.3	38	3	2
0.84	Ext.	★		0084SB	10	14.2	38	3	2
0.85	Ext.	★		0085SB	10	14.2	38	3	2
0.86	Ext.	★		0086SB	10	14.2	38	3	2
0.87	Ext.	★		0087SB	10	14.2	38	3	2
0.88	Ext.	★		0088SB	10	14.2	38	3	2
0.89	Ext.	★		0089SB	10	14.1	38	3	2
0.90	Ext.	●		0090SB	10	14.1	38	3	2
0.91	Ext.	★		0091SB	10	14.1	38	3	2
0.92	Ext.	★		0092SB	10	14.1	38	3	2
0.93	Ext.	★		0093SB	10	14.1	38	3	2
0.94	Ext.	★		0094SB	10	14.0	38	3	2
0.95	Ext.	★		0095SB	10	14.0	38	3	2
0.96	Ext.	★		0096SB	10	14.0	38	3	2
0.97	Ext.	★		0097SB	10	14.0	38	3	2
0.98	Ext.	★		0098SB	10	14.0	38	3	2
0.99	Ext.	★		0099SB	10	14.0	38	3	2
1.00	Ext.	●		0100SB	10	13.9	38	3	2
1.01	Ext.	★		0101SB	10	13.9	38	3	2
1.02	Ext.	●		0102SB	10	13.9	38	3	2
1.03	Ext.	★		0103SB	10	13.9	38	3	2
1.04	Ext.	★		0104SB	10	13.9	38	3	2
1.05	Ext.	★		0105SB	10	13.8	38	3	2
1.06	Ext.	★		0106SB	10	13.8	38	3	2
1.07	Ext.	★		0107SB	10	13.8	38	3	2
1.08	Ext.	★		0108SB	10	13.8	38	3	2
1.09	Ext.	★		0109SB	10	13.8	38	3	2
1.10	Ext.	●		0110SB	10	13.7	38	3	2
1.11	Ext.	★		0111SB	10	13.7	38	3	2
1.12	Ext.	★		0112SB	10	13.7	38	3	2
1.13	Ext.	★		0113SB	10	13.7	38	3	2
1.14	Ext.	★		0114SB	10	13.7	38	3	2
1.15	Ext.	★		0115SB	10	13.7	38	3	2
1.16	Ext.	★		0116SB	10	13.6	38	3	2
1.17	Ext.	★		0117SB	10	13.6	38	3	2
1.18	Ext.	★		0118SB	10	13.6	38	3	2
1.19	Ext.	★		0119SB	10	13.6	38	3	2
1.20	Ext.	●		0120SB	10	13.6	38	3	2
1.21	Ext.	★		0121SB	10	13.5	38	3	2
1.22	Ext.	★		0122SB	10	13.5	38	3	2
1.23	Ext.	★		0123SB	10	13.5	38	3	2
1.24	Ext.	★		0124SB	10	13.5	38	3	2
1.25	Ext.	★		0125SB	10	13.5	38	3	2
1.26	Ext.	★		0126SB	10	13.4	38	3	2
1.27	Ext.	★		0127SB	10	13.4	38	3	2

Drill Dia. D1 (mm)	Coolant (Int./Ext.)	Stock		Order Number	Dimensions (mm)				Type
		VP20MF	VP15TF		L3	L2	L1	D4	
1.28	Ext.	★		MSE0128SB	10	13.4	38	3	2
1.29	Ext.	★		0129SB	10	13.4	38	3	2
1.30	Ext.	★		0130SB	10	13.4	38	3	2
1.31	Ext.	★		0131SB	10	13.4	38	3	2
1.32	Ext.	★		0132SB	10	13.3	38	3	2
1.33	Ext.	★		0133SB	10	13.3	38	3	2
1.34	Ext.	★		0134SB	10	13.3	38	3	2
1.35	Ext.	★		0135SB	10	13.3	38	3	2
1.36	Ext.	★		0136SB	10	13.3	38	3	2
1.37	Ext.	★		0137SB	10	13.2	38	3	2
1.38	Ext.	★		0138SB	10	13.2	38	3	2
1.39	Ext.	★		0139SB	10	13.2	38	3	2
1.40	Ext.	●		0140SB	10	13.2	38	3	2
1.41	Ext.	★		0141SB	10	13.2	38	3	2
1.42	Ext.	★		0142SB	10	13.1	38	3	2
1.43	Ext.	★		0143SB	10	13.1	38	3	2
1.44	Ext.	★		0144SB	10	13.1	38	3	2
1.45	Ext.	●		0145SB	10	13.1	38	3	2
1.46	Ext.	★		0146SB	10	13.1	38	3	2
1.47	Ext.	★		0147SB	10	13.1	38	3	2
1.48	Ext.	★		0148SB	10	13.0	38	3	2
1.49	Ext.	★		0149SB	10	13.0	38	3	2
1.50	Ext.	●		0150SB	10	13.0	38	3	2
1.51	Ext.	★		0151SB	10	13.0	38	3	2
1.52	Ext.	★		0152SB	10	13.0	38	3	2
1.53	Ext.	★		0153SB	10	12.9	38	3	2
1.54	Ext.	★		0154SB	10	12.9	38	3	2
1.55	Ext.	★		0155SB	10	12.9	38	3	2
1.56	Ext.	★		0156SB	10	12.9	38	3	2
1.57	Ext.	★		0157SB	10	12.9	38	3	2
1.58	Ext.	★		0158SB	10	12.8	38	3	2
1.59	Ext.	★		0159SB	10	12.8	38	3	2
1.60	Ext.	●		0160SB	12	14.6	45	3	2
1.61	Ext.	★		0161SB	12	14.6	45	3	2
1.62	Ext.	★		0162SB	12	14.6	45	3	2
1.63	Ext.	★		0163SB	12	14.6	45	3	2
1.64	Ext.	★		0164SB	12	14.5	45	3	2
1.65	Ext.	★		0165SB	12	14.5	45	3	2
1.66	Ext.	★		0166SB	12	14.5	45	3	2
1.67	Ext.	★		0167SB	12	14.5	45	3	2
1.68	Ext.	★		0168SB	12	14.5	45	3	2
1.69	Ext.	★		0169SB	12	14.4	45	3	2
1.70	Ext.	●		0170SB	12	14.4	45	3	2
1.71	Ext.	★		0171SB	12	14.4	45	3	2
1.72	Ext.	★		0172SB	12	14.4	45	3	2
1.73	Ext.	★		0173SB	12	14.4	45	3	2
1.74	Ext.	★		0174SB	12	14.4	45	3	2
1.75	Ext.	★		0175SB	12	14.3	45	3	2
1.76	Ext.	★		0176SB	12	14.3	45	3	2
1.77	Ext.	★		0177SB	12	14.3	45	3	2

MSE DRILLS



Ø 0.78 ~ 1.77



DRILLING (SOLID CARBIDE)

MSE

- Wide flute for preventing chip jamming.
- Stable, small diameter machining.



P	M	K	S	N	H
✓	✓	✓	✓	✓	✓

D1	0.10 ≤ D1 ≤ 3.00
Tolerance	0 -0.009

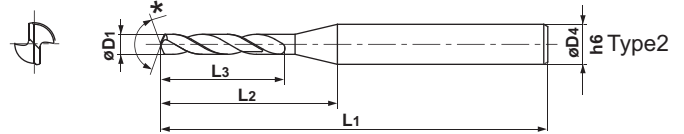

*Drill Dia. ϕ 0.30–1.59 : 130°
 ϕ 1.60–2.50 : 140°

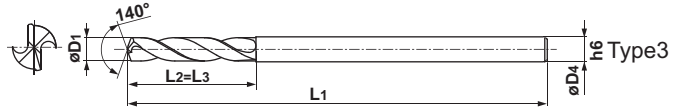

DRILLING MSE, MSP DRILLS

Drill Dia. D1 (mm)	Coolant (Int./Ext.)	Stock		Order Number	Dimensions (mm)				Type
		VP20MF	VP15TF		L3	L2	L1	D4	
1.78	Ext.		★	MSE0178SB	12	14.3	45	3	2
1.79	Ext.		★	0179SB	12	14.3	45	3	2
1.80	Ext.		●	0180SB	12	14.2	45	3	2
1.81	Ext.		★	0181SB	12	14.2	45	3	2
1.82	Ext.		★	0182SB	12	14.2	45	3	2
1.83	Ext.		★	0183SB	12	14.2	45	3	2
1.84	Ext.		★	0184SB	12	14.2	45	3	2
1.85	Ext.		●	0185SB	12	14.1	45	3	2
1.86	Ext.		★	0186SB	12	14.1	45	3	2
1.87	Ext.		★	0187SB	12	14.1	45	3	2
1.88	Ext.		★	0188SB	12	14.1	45	3	2
1.89	Ext.		★	0189SB	12	14.1	45	3	2
1.90	Ext.		●	0190SB	12	14.1	45	3	2
1.91	Ext.		★	0191SB	12	14.0	45	3	2
1.92	Ext.		★	0192SB	12	14.0	45	3	2
1.93	Ext.		★	0193SB	12	14.0	45	3	2
1.94	Ext.		★	0194SB	12	14.0	45	3	2
1.95	Ext.		★	0195SB	12	14.0	45	3	2
1.96	Ext.		★	0196SB	12	13.9	45	3	2
1.97	Ext.		★	0197SB	12	13.9	45	3	2
1.98	Ext.		★	0198SB	12	13.9	45	3	2
1.99	Ext.		★	0199SB	12	13.9	45	3	2

Drill Dia. D1 (mm)	Coolant (Int./Ext.)	Stock		Order Number	Dimensions (mm)				Type
		VP20MF	VP15TF		L3	L2	L1	D4	
2.00	Ext.		●	MSE0200SB	15	16.9	50	3	2
2.05	Ext.		●	0205SB	15	16.8	50	3	2
2.10	Ext.		●	0210SB	15	16.7	50	3	2
2.15	Ext.		★	0215SB	15	16.6	50	3	2
2.20	Ext.		★	0220SB	15	16.5	50	3	2
2.25	Ext.		★	0225SB	15	16.4	50	3	2
2.30	Ext.		★	0230SB	15	16.3	50	3	2
2.35	Ext.		★	0235SB	15	16.2	50	3	2
2.40	Ext.		★	0240SB	15	16.1	50	3	2
2.45	Ext.		★	0245SB	15	16.0	50	3	2
2.50	Ext.		●	0250SB	15	15.9	50	3	2
2.55	Ext.		●	0255SB	15	15	50	3	3
2.60	Ext.		★	0260SB	15	15	50	3	3
2.65	Ext.		★	0265SB	15	15	50	3	3
2.70	Ext.		★	0270SB	15	15	50	3	3
2.75	Ext.		●	0275SB	15	15	50	3	3
2.80	Ext.		●	0280SB	15	15	50	3	3
2.85	Ext.		●	0285SB	15	15	50	3	3
2.90	Ext.		★	0290SB	15	15	50	3	3
2.95	Ext.		★	0295SB	15	15	50	3	3
3.00	Ext.		★	0300SB	15	15	50	3	3

(Note) Please contact us for any geometry that is not in this catalogue (e.g. different diameters and lengths can be made to order).

MSP



P	M	K	S	N	H
✓	✓	✓	✓	✓	✓

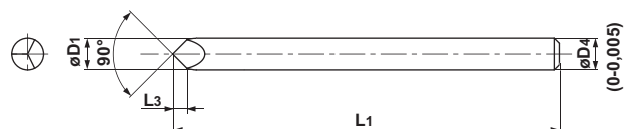

Order Number	Grade	Stock	Dimension (mm)				Diameter Range (mm)
			D1	L3	L1	D4	
MSP0300SB	VP15TF	●	3	1.5	38	3	0.1–3.0

- : Stock Standard.
- ★ : Stock Standard in Japan.
- : Non stock, produced to order only.

RECOMMENDED CUTTING CONDITIONS

Work Material	Hardness	Drill Dia. $\phi 0.10$ – $\phi 0.19$			Drill Dia. $\phi 0.20$ – $\phi 0.29$			Drill Dia. $\phi 0.30$ – $\phi 0.49$		
		Revolution (min ⁻¹)	Feed (mm/rev)	Step (mm)	Revolution (min ⁻¹)	Feed (mm/rev)	Step (mm)	Revolution (min ⁻¹)	Feed (mm/rev)	Step (mm)
P General Steel Carbon Steel	≤ 180HB	20000	0.002	0.02	20000	0.003	0.04	20000	0.004	0.05
Alloy Steel Pre-Hardened Steel	≤ 40HRC	20000	0.002	0.02	20000	0.003	0.04	20000	0.004	0.05
M Stainless Steel	≤ 200HB	20000	0.002	0.02	18000	0.003	0.04	15000	0.004	0.05
K Cast Iron	Tensile Strength ≤ 350N/mm ²	20000	0.002	0.02	20000	0.003	0.04	20000	0.004	0.05
N Aluminium Alloy	–	20000	0.004	0.05	20000	0.006	0.1	20000	0.02	0.3
S Heat Resistant Alloy	–	7000	0.001	0.02	5000	0.002	0.04	4000	0.003	0.05

Work Material	Hardness	Drill Dia. $\phi 0.50$ – $\phi 0.79$			Drill Dia. $\phi 0.80$ – $\phi 0.99$			Drill Dia. $\phi 1.00$ – $\phi 1.19$		
		Revolution (min ⁻¹)	Feed (mm/rev)	Step (mm)	Revolution (min ⁻¹)	Feed (mm/rev)	Step (mm)	Revolution (min ⁻¹)	Feed (mm/rev)	Step (mm)
P General Steel Carbon Steel	≤ 180HB	20000	0.01	0.1	20000	0.04	0.3	16000	0.06	0.5
Alloy Steel Pre-Hardened Steel	≤ 40HRC	20000	0.01	0.1	20000	0.02	0.3	16000	0.03	0.5
M Stainless Steel	≤ 200HB	10000	0.01	0.1	6000	0.02	0.2	5000	0.03	0.3
K Cast Iron	Tensile Strength ≤ 350N/mm ²	20000	0.01	0.1	20000	0.04	0.3	16000	0.06	0.5
N Aluminium Alloy	–	20000	0.05	0.5	20000	0.06	0.8	20000	0.08	1.0
S Heat Resistant Alloy	–	3000	0.005	0.1	1800	0.01	0.2	1000	0.015	0.3

Work Material	Hardness	Drill Dia. $\phi 1.20$ – $\phi 1.49$			Drill Dia. $\phi 1.50$ – $\phi 1.99$			Drill Dia. $\phi 2.00$ – $\phi 2.45$		
		Revolution (min ⁻¹)	Feed (mm/rev)	Step (mm)	Revolution (min ⁻¹)	Feed (mm/rev)	Step (mm)	Revolution (min ⁻¹)	Feed (mm/rev)	Step (mm)
P General Steel Carbon Steel	≤ 180HB	13000	0.07	0.6	12000	0.08	0.7	9500	0.10	0.8
Alloy Steel Pre-Hardened Steel	≤ 40HRC	13000	0.05	0.6	10000	0.06	0.7	7000	0.07	0.8
M Stainless Steel	≤ 200HB	4000	0.03	0.4	3000	0.04	0.5	3000	0.05	0.6
K Cast Iron	Tensile Strength ≤ 350N/mm ²	13000	0.07	0.6	12000	0.08	0.7	9500	0.10	0.8
N Aluminium Alloy	–	18000	0.10	1.2	15000	0.10	1.5	12000	0.12	2.0
S Heat Resistant Alloy	–	–	–	–	–	–	–	–	–	–

Work Material	Hardness	Drill Dia. $\phi 2.50$ – $\phi 2.95$			Drill Dia. $\phi 3.00$		
		Revolution (min ⁻¹)	Feed (mm/rev)	Step (mm)	Revolution (min ⁻¹)	Feed (mm/rev)	Step (mm)
P General Steel Carbon Steel	≤ 180HB	7600	0.12	0.9	6300	0.12	1.0
Alloy Steel Pre-Hardened Steel	≤ 40HRC	5500	0.08	0.9	4500	0.10	1.0
M Stainless Steel	≤ 200HB	2500	0.08	0.7	2000	0.10	0.8
K Cast Iron	Tensile Strength ≤ 350N/mm ²	7600	0.12	0.9	6300	0.12	1.0
N Aluminium Alloy	–	9000	0.12	2.5	7500	0.15	3.0
S Heat Resistant Alloy	–	–	–	–	–	–	–

Notes:

- When drilling holes up to $\phi 0.3$ mm, the use of a spot drill is recommended.
(Order number : MSP0300SB, Cutting conditions : See below.)
- Change the cutting conditions depending on your machine and workpiece rigidity.
- When machining holes over 5D, reduce the peck distance stated above.
- The use of water-soluble fluid (diluted 20 times) is recommended for drilling using the cutting conditions above.
Lower the revolutions if oil fluid or mist is used.
- Work materials marked by "–" in the tables above are difficult to drill with external coolant.
The use of internal coolant type MZS or VAPDSSUS is recommended.

Order Number	Revolution (min ⁻¹)	Table Feed (mm/min)
MSP0300SB	10000	5.0



MWE / MWS

Supreme wavy cutting edge & flute geometry, excellent for multi purpose drilling applications from general steels through to difficult-to-cut materials.

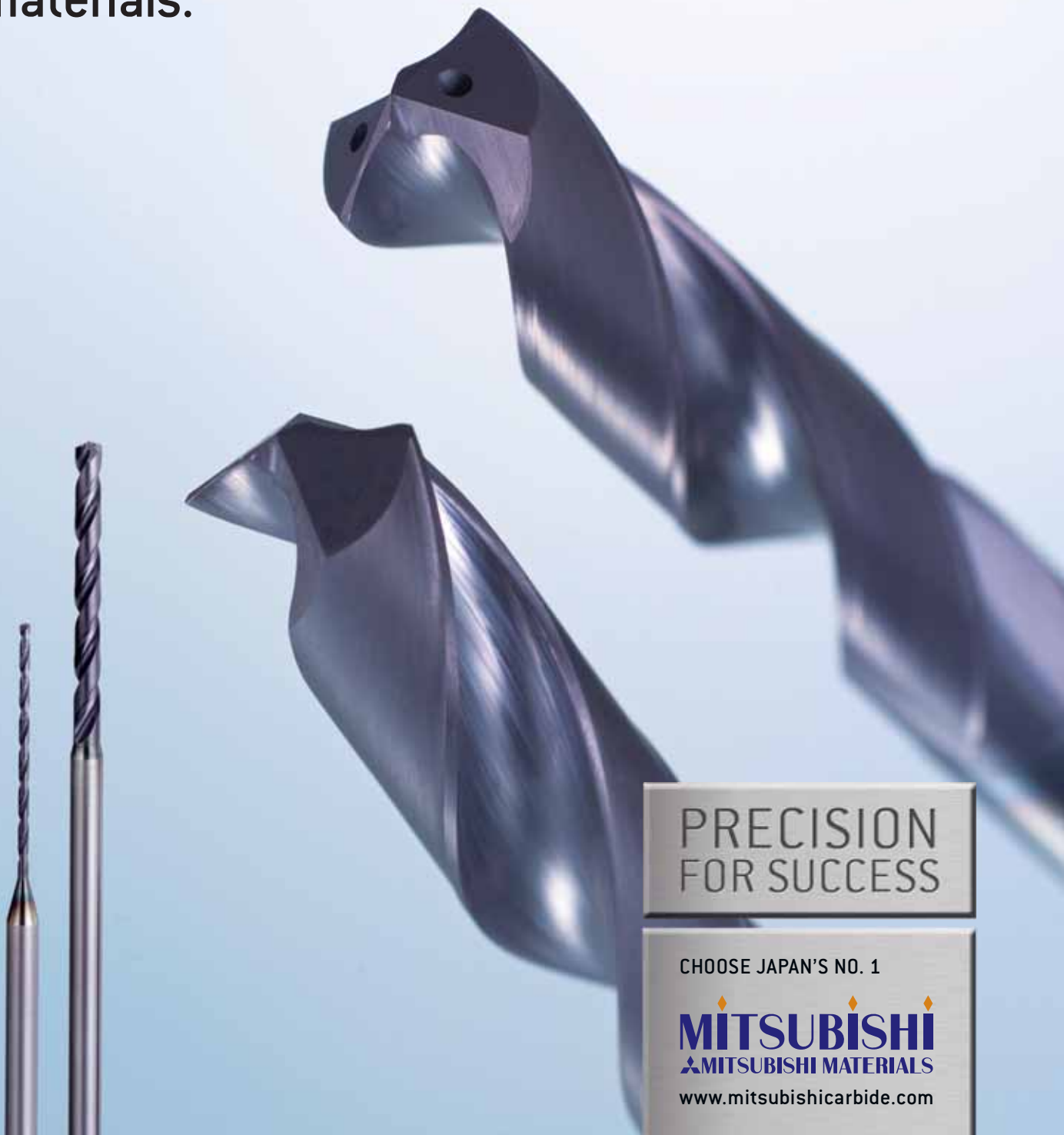

PRECISION
FOR SUCCESS

CHOOSE JAPAN'S NO. 1

mitsubishi
MITSUBISHI MATERIALS

www.mitsubishicarbide.com

MIRACLE[®] coated Solid carbide drill

MWE/MWS

Features

- Wavy cutting edge & special flute geometry to promote smooth chip evacuation

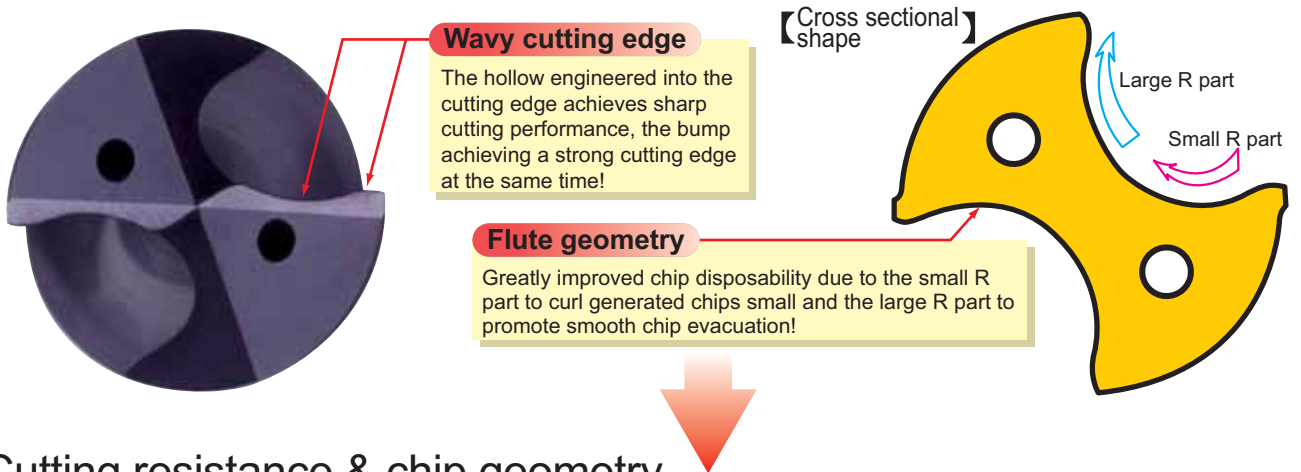

- Cutting resistance & chip geometry

MWE/MWS lower cutting resistance and power consumption, exhibiting excellent chip disposability with compact chip discharge!

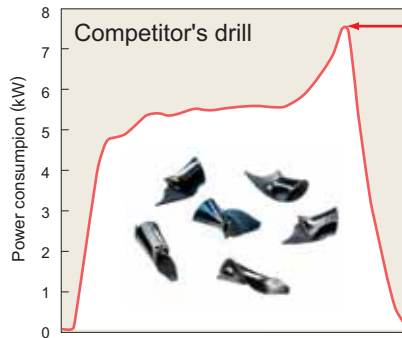
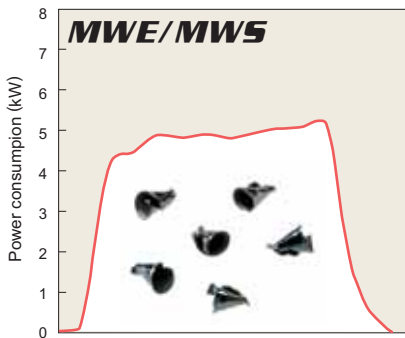

Chip packing occurred right before passing through

<Cutting conditions>
Workpiece : Cf53 (1.1213) 150-180HB
Drill diameter : \varnothing 12 (Internal coolant)
Hole depth : 60mm
Cutting speed : 120m/min
Feed : 0.25mm/rev
Collant : WSO
Oil pressure : 0.5MPa

- Long tool life **MIRACLE[®] coated VP15TF**

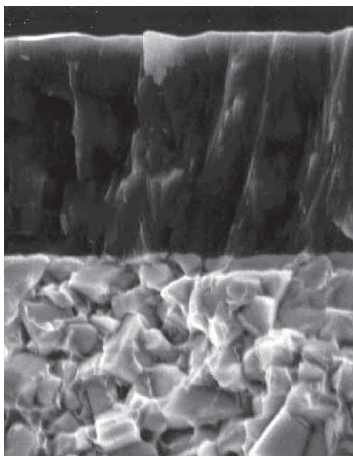

Miracle[®] coated
(Al, Ti)N

TF15 micrograin
cemented carbide



Features of **VP15TF**

Miracle coated **VP15TF** displays high welding resistance therefore it can be used for machining a wide range of workpiece materials such as Mild steels, Carbon steels, Alloy steel Stainless steels and Cast irons.

VP15TF

● Centripetal top edge geometry

Top edge geometry

Centripetal top edge geometry with the small point angle and X-thinning achieves highly accurate hole positions! ($\theta_1 < \theta_2$)

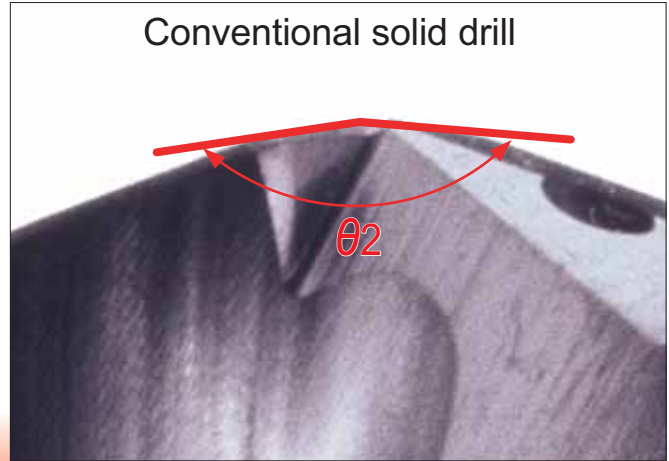
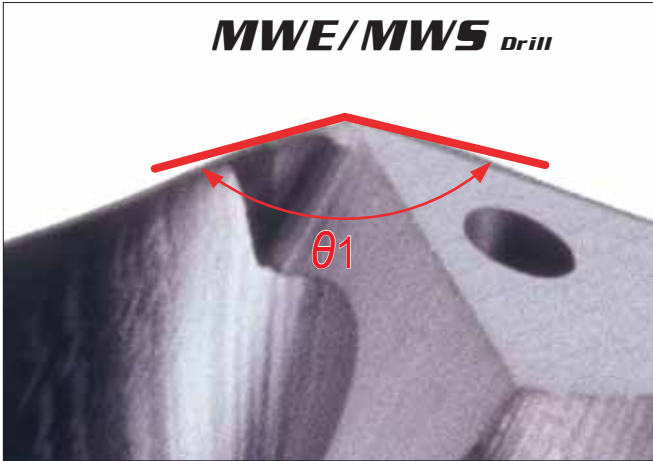

● Machining accuracy (over size)

MWE/MWS Drills are highly wear resistant for maintaining hole size accuracy!

MWE, MWS DRILLS

From the beginning to the end of machining, components of a horizontal force, F_x and F_y , stay small and stable.

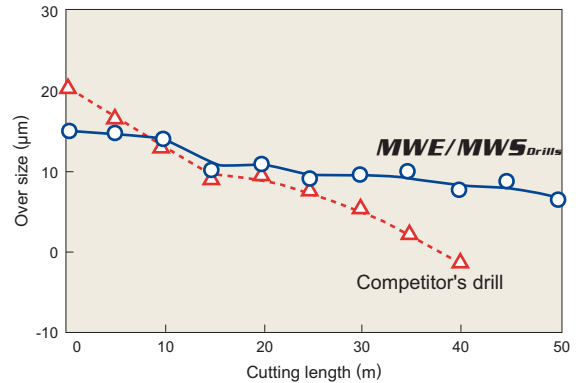
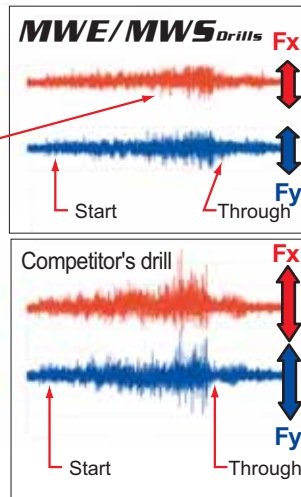
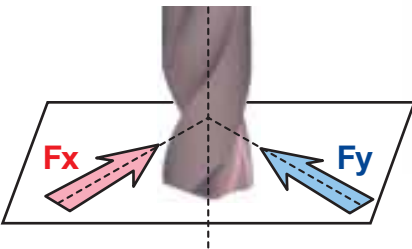

<Cutting conditions>

Workpiece : Cf53 (1.1213) 150-180HB Feed : 0.2mm/rev
 Drill diameter : $\varnothing 8$ (Internal coolant) Coolant : Emulsion 10%
 Cutting speed : 80m/min Oil pressure : 0.5MPa

● Tool life

MWE/MWS-Drills are highly flank and margin wear resistant!

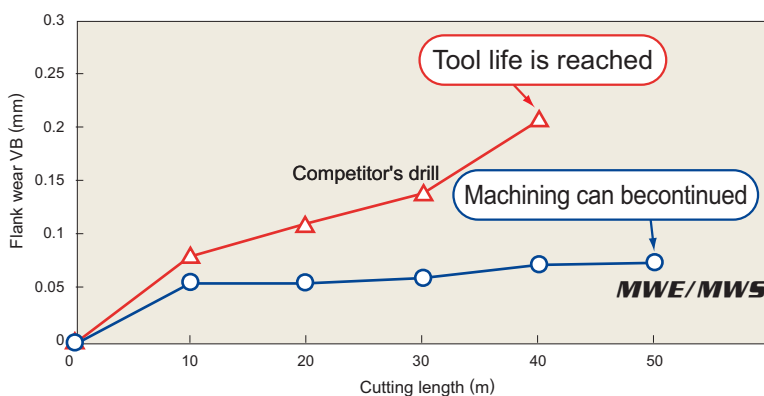

Enlarged picture of the margin after drilling 40m

Competitor's drill

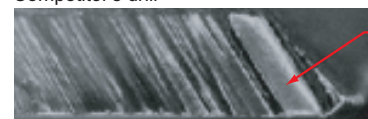

MWE/MWS-Drills



<Cutting conditions>

Workpiece : Cf53 (1.1213) 150-180HB Cutting speed : 80m/min
 Drill diameter : $\varnothing 8$ (Internal coolant) Feed : 0.2mm/rev
 Coolant : Emulsion 10% Hole depth : 25mm
 (Through hole) Oil pressure : 0.5MPa



MWS (Internal coolant)

SB Type (For pilot holes)

D1	0.5 ≤ D1 < 1.0	1.0 ≤ D1 < 2.95
Tolerance	+0.009 0	+0.014 0

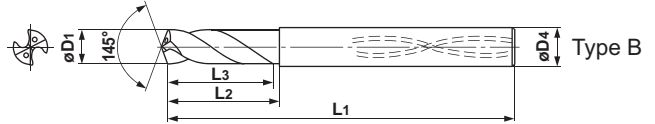
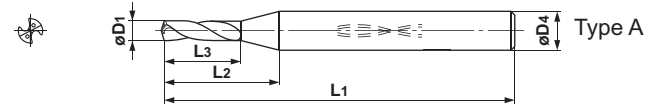

LB/XB Type

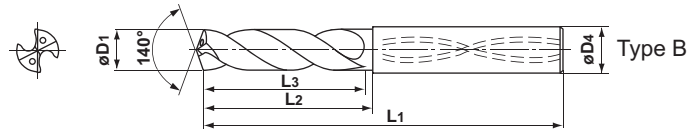
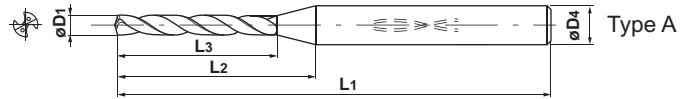

(Note) MWS type can be used for shrink fit holders.

Drill Dia. D1 (mm)	Hole Depth (l/d)	Coolant (Int./Ext.)	Stock VP15TF	Order Number	Dimensions (mm)				Type
					L3	L2	L1	D4	
0.50	1	Int.	●	MWS0050SB	2.5	7.2	47	3	A
	5	Int.	★	MWS0050LB	8	13	47	3	A
	12	Int.	★	MWS0050XB	16	21	47	3	A
0.51	1	Int.	□	MWS0051SB	2.6	7.2	47	3	A
	5	Int.	★	MWS0051LB	8	13	47	3	A
	12	Int.	★	MWS0051XB	16	21	47	3	A
0.52	1	Int.	□	MWS0052SB	2.6	7.2	47	3	A
	5	Int.	★	MWS0052LB	8	13	47	3	A
	12	Int.	★	MWS0052XB	16	21	47	3	A
0.53	1	Int.	□	MWS0053SB	2.6	7.2	47	3	A
	5	Int.	★	MWS0053LB	8	13	47	3	A
	12	Int.	★	MWS0053XB	16	21	47	3	A
0.54	1	Int.	□	MWS0054SB	2.6	7.2	47	3	A
	5	Int.	★	MWS0054LB	8	13	47	3	A
	12	Int.	★	MWS0054XB	16	21	47	3	A
0.55	1	Int.	●	MWS0055SB	2.6	7.2	47	3	A
	5	Int.	★	MWS0055LB	8	13	47	3	A
	12	Int.	★	MWS0055XB	16	21	47	3	A
0.56	1	Int.	□	MWS0056SB	2.9	7.5	47	3	A
	5	Int.	★	MWS0056LB	8	13	47	3	A
	12	Int.	★	MWS0056XB	16	21	47	3	A
0.57	1	Int.	□	MWS0057SB	2.9	7.4	47	3	A
	5	Int.	★	MWS0057LB	8	13	47	3	A
	12	Int.	★	MWS0057XB	16	21	47	3	A
0.58	1	Int.	□	MWS0058SB	2.9	7.4	47	3	A
	5	Int.	★	MWS0058LB	8	13	47	3	A
	12	Int.	★	MWS0058XB	16	21	47	3	A
0.59	1	Int.	□	MWS0059SB	2.9	7.4	47	3	A
	5	Int.	★	MWS0059LB	8	12	47	3	A
	12	Int.	★	MWS0059XB	16	20	47	3	A

Drill Dia. D1 (mm)	Hole Depth (l/d)	Coolant (Int./Ext.)	Stock VP15TF	Order Number	Dimensions (mm)				Type
					L3	L2	L1	D4	
0.60	1	Int.	●	MWS0060SB	2.9	7.4	47	3	A
	5	Int.	★	MWS0060LB	8	12	47	3	A
	12	Int.	★	MWS0060XB	16	20	47	3	A
0.61	1	Int.	□	MWS0061SB	3.1	7.6	47	3	A
	5	Int.	★	MWS0061LB	8	12	47	3	A
	12	Int.	★	MWS0061XB	16	20	47	3	A
0.62	1	Int.	□	MWS0062SB	3.1	7.5	47	3	A
	5	Int.	★	MWS0062LB	8	12	47	3	A
	12	Int.	★	MWS0062XB	16	20	47	3	A
0.63	1	Int.	□	MWS0063SB	3.1	7.5	47	3	A
	5	Int.	★	MWS0063LB	8	12	47	3	A
	12	Int.	★	MWS0063XB	16	20	47	3	A
0.64	1	Int.	□	MWS0064SB	3.1	7.5	47	3	A
	5	Int.	★	MWS0064LB	8	12	47	3	A
	12	Int.	★	MWS0064XB	16	20	47	3	A
0.65	1	Int.	●	MWS0065SB	3.1	7.5	47	3	A
	5	Int.	★	MWS0065LB	8	12	47	3	A
	12	Int.	★	MWS0065XB	16	20	47	3	A
0.66	1	Int.	□	MWS0066SB	3.4	7.8	47	3	A
	5	Int.	★	MWS0066LB	8	12	47	3	A
	12	Int.	★	MWS0066XB	16	20	47	3	A
0.67	1	Int.	□	MWS0067SB	3.4	7.7	47	3	A
	5	Int.	★	MWS0067LB	8	12	47	3	A
	12	Int.	★	MWS0067XB	16	20	47	3	A
0.68	1	Int.	□	MWS0068SB	3.4	7.7	47	3	A
	5	Int.	★	MWS0068LB	8	12	47	3	A
	12	Int.	★	MWS0068XB	16	20	47	3	A
0.69	1	Int.	□	MWS0069SB	3.4	7.7	47	3	A
	5	Int.	★	MWS0069LB	8	12	47	3	A
	12	Int.	★	MWS0069XB	16	20	47	3	A

(Note) Please contact us for any geometry that is not in this catalogue (e.g. different diameters and lengths can be made to order).



Ø 0.50 ~ 0.69



DRILLING (SOLID CARBIDE)

MWE, MWS

- Suitable for high efficiency and high accuracy drilling over a wide variety of materials from general steel to difficult-to-cut materials.
- ★ Suitable for low to high speed cutting. Possible to use in the range of HSS cutting.



P	M	K	S	N	H
✓	✓	✓	✓	✓	✓

MWS (Internal coolant)

SB Type (For pilot holes)

D1	0.5 ≤ D1 < 1.0	1.0 ≤ D1 < 2.95
Tolerance	+0.009 0	+0.014 0

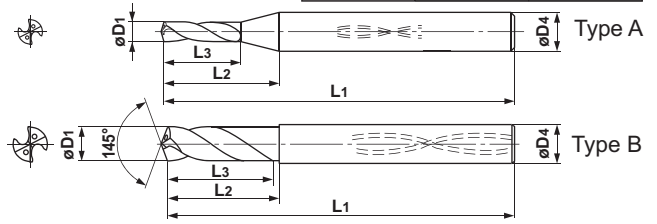

LB/XB Type

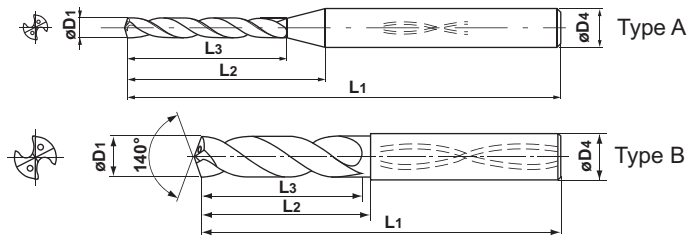

DB Type



(Note) MWS type can be used for shrink fit holders.

Drill Dia. D1 (mm)	Hole Depth (l/d)	Coolant (Int./Ext.)	Stock VP15TF	Order Number	Dimensions (mm)				Type
					L3	L2	L1	D4	
0.70	1	Int.	●	MWS0070SB	3.4	7.7	47	3	A
	5	Int.	★	MWS0070LB	8	12	47	3	A
	12	Int.	★	MWS0070XB	16	20	47	3	A
0.71	1	Int.	□	MWS0071SB	3.6	7.9	50	3	A
	5	Int.	★	MWS0071LB	10	14	50	3	A
	12	Int.	★	MWS0071XB	20	24	50	3	A
0.72	1	Int.	□	MWS0072SB	3.6	7.9	50	3	A
	5	Int.	★	MWS0072LB	10	14	50	3	A
	12	Int.	★	MWS0072XB	20	24	50	3	A
0.73	1	Int.	□	MWS0073SB	3.6	7.8	50	3	A
	5	Int.	★	MWS0073LB	10	14	50	3	A
	12	Int.	★	MWS0073XB	20	24	50	3	A
0.74	1	Int.	□	MWS0074SB	3.6	7.8	50	3	A
	5	Int.	★	MWS0074LB	10	14	50	3	A
	12	Int.	★	MWS0074XB	20	24	50	3	A
0.75	1	Int.	●	MWS0075SB	3.6	7.8	50	3	A
	5	Int.	★	MWS0075LB	10	14	50	3	A
	12	Int.	★	MWS0075XB	20	24	50	3	A
0.76	1	Int.	□	MWS0076SB	3.9	8.1	50	3	A
	5	Int.	★	MWS0076LB	10	14	50	3	A
	12	Int.	★	MWS0076XB	20	24	50	3	A
0.77	1	Int.	□	MWS0077SB	3.9	8.1	50	3	A
	5	Int.	★	MWS0077LB	10	14	50	3	A
	12	Int.	★	MWS0077XB	20	24	50	3	A
0.78	1	Int.	□	MWS0078SB	3.9	8.0	50	3	A
	5	Int.	★	MWS0078LB	10	14	50	3	A
	12	Int.	★	MWS0078XB	20	24	50	3	A
0.79	1	Int.	□	MWS0079SB	3.9	8.0	50	3	A
	5	Int.	★	MWS0079LB	10	14	50	3	A
	12	Int.	★	MWS0079XB	20	24	50	3	A

Drill Dia. D1 (mm)	Hole Depth (l/d)	Coolant (Int./Ext.)	Stock VP15TF	Order Number	Dimensions (mm)				Type
					L3	L2	L1	D4	
0.80	1	Int.	●	MWS0080SB	3.9	8.0	50	3	A
	5	Int.	★	MWS0080LB	10	14	50	3	A
	12	Int.	★	MWS0080XB	20	24	50	3	A
0.81	1	Int.	□	MWS0081SB	4.1	8.2	50	3	A
	5	Int.	★	MWS0081LB	10	14	50	3	A
	12	Int.	★	MWS0081XB	20	24	50	3	A
0.82	1	Int.	□	MWS0082SB	4.1	8.2	50	3	A
	5	Int.	★	MWS0082LB	10	14	50	3	A
	12	Int.	★	MWS0082XB	20	24	50	3	A
0.83	1	Int.	□	MWS0083SB	4.1	8.1	50	3	A
	5	Int.	★	MWS0083LB	10	14	50	3	A
	12	Int.	★	MWS0083XB	20	24	50	3	A
0.84	1	Int.	□	MWS0084SB	4.1	8.1	50	3	A
	5	Int.	★	MWS0084LB	10	14	50	3	A
	12	Int.	★	MWS0084XB	20	24	50	3	A
0.85	1	Int.	●	MWS0085SB	4.1	8.1	50	3	A
	5	Int.	★	MWS0085LB	10	14	50	3	A
	12	Int.	★	MWS0085XB	20	24	50	3	A
0.86	1	Int.	□	MWS0086SB	4.4	8.4	50	3	A
	5	Int.	★	MWS0086LB	10	14	50	3	A
	12	Int.	★	MWS0086XB	20	24	50	3	A
0.87	1	Int.	□	MWS0087SB	4.4	8.4	50	3	A
	5	Int.	★	MWS0087LB	10	14	50	3	A
	12	Int.	★	MWS0087XB	20	24	50	3	A
0.88	1	Int.	□	MWS0088SB	4.4	8.4	50	3	A
	5	Int.	★	MWS0088LB	10	14	50	3	A
	12	Int.	★	MWS0088XB	20	24	50	3	A
0.89	1	Int.	□	MWS0089SB	4.4	8.3	50	3	A
	5	Int.	★	MWS0089LB	10	14	50	3	A
	12	Int.	★	MWS0089XB	20	24	50	3	A

(Note) Please contact us for any geometry that is not in this catalogue (e.g. different diameters and lengths can be made to order).

- : Stock Standard.
- ★ : Stock Standard in Japan.
- : Non stock, produced to order only.

DRILLING (SOLID CARBIDE)

MWE, MWS

- Suitable for high efficiency and high accuracy drilling over a wide variety of materials from general steel to difficult-to-cut materials.
- Suitable for low to high speed cutting. Possible to use in the range of HSS cutting.



MWS (Internal coolant)

SB Type (For pilot holes)

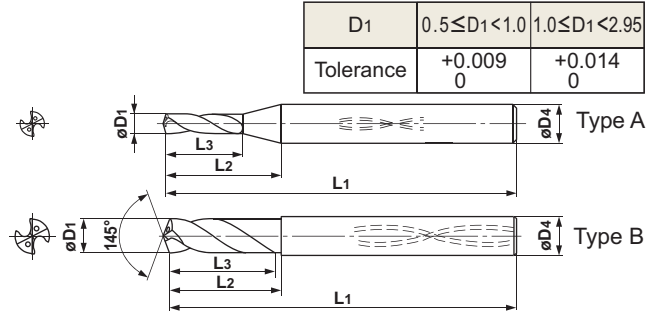

LB/XB Type

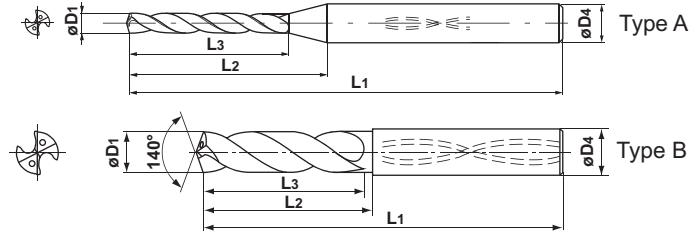

DB Type



(Note) MWS type can be used for shrink fit holders.

Drill Dia. D1 (mm)	Hole Depth (l/d)	Coolant (Int./Ext.)	Stock VP15TF	Order Number	Dimensions (mm)				Type
					L3	L2	L1	D4	
2.00	1	Int.	●	MWS0200SB	10.0	11.9	68	3	A
	5	Int.	●	MWS0200LB	22	24	68	3	A
	12	Int.	●	MWS0200XB	30	32	68	3	A
	20	Int.	●	MWS0200X20DB	46	48	84	3	A
	25	Int.	●	MWS0200X25DB	56	58	94	3	A
	30	Int.	●	MWS0200X30DB	66	68	102	3	A
2.05	1	Int.	●	MWS0205SB	10.2	12.0	74	3	A
	20	Int.	●	MWS0205X20DB	47	49	94	3	A
	25	Int.	●	MWS0205X25DB	57	59	107	3	A
	30	Int.	●	MWS0205X30DB	68	69	118	3	A
2.10	1	Int.	●	MWS0210SB	10.4	12.1	74	3	A
	5	Int.	●	MWS0210LB	28	30	74	3	A
	12	Int.	●	MWS0210XB	38	40	74	3	A
	20	Int.	●	MWS0210X20DB	48	50	94	3	A
	25	Int.	●	MWS0210X25DB	59	60	107	3	A
	30	Int.	●	MWS0210X30DB	69	71	118	3	A
2.15	1	Int.	●	MWS0215SB	10.6	12.2	74	3	A
	20	Int.	□	MWS0215X20DB	49	51	94	3	A
	25	Int.	□	MWS0215X25DB	60	62	107	3	A
	30	Int.	□	MWS0215X30DB	71	73	118	3	A
2.20	1	Int.	●	MWS0220SB	11.0	12.5	74	3	A
	5	Int.	●	MWS0220LB	28	29	74	3	A
	12	Int.	●	MWS0220XB	38	39	74	3	A
	20	Int.	●	MWS0220X20DB	51	52	94	3	A
	25	Int.	●	MWS0220X25DB	62	63	107	3	A
	30	Int.	●	MWS0220X30DB	73	74	118	3	A
2.25	1	Int.	●	MWS0225SB	11.2	12.6	74	3	A
	20	Int.	□	MWS0225X20DB	52	53	94	3	A
	25	Int.	□	MWS0225X25DB	63	64	107	3	A
	30	Int.	□	MWS0225X30DB	74	76	118	3	A

Drill Dia. D1 (mm)	Hole Depth (l/d)	Coolant (Int./Ext.)	Stock VP15TF	Order Number	Dimensions (mm)				Type
					L3	L2	L1	D4	
2.30	1	Int.	●	MWS0230SB	11.4	12.7	74	3	A
	5	Int.	●	MWS0230LB	28	29	74	3	A
	12	Int.	●	MWS0230XB	38	39	74	3	A
	20	Int.	●	MWS0230X20DB	53	54	94	3	A
	25	Int.	●	MWS0230X25DB	64	66	107	3	A
	30	Int.	●	MWS0230X30DB	76	77	118	3	A
2.35	1	Int.	●	MWS0235SB	11.6	12.8	74	3	A
	20	Int.	□	MWS0235X20DB	54	55	94	3	A
	25	Int.	□	MWS0235X25DB	66	67	107	3	A
	30	Int.	□	MWS0235X30DB	78	79	118	3	A
2.40	1	Int.	●	MWS0240SB	12.0	13.1	74	3	A
	5	Int.	●	MWS0240LB	28	29	74	3	A
	12	Int.	●	MWS0240XB	38	39	74	3	A
	20	Int.	●	MWS0240X20DB	55	56	94	3	A
	25	Int.	●	MWS0240X25DB	67	68	107	3	A
	30	Int.	●	MWS0240X30DB	79	80	118	3	A
2.45	1	Int.	●	MWS0245SB	12	13	74	3	A
	20	Int.	□	MWS0245X20DB	56	57	94	3	A
	25	Int.	□	MWS0245X25DB	69	70	107	3	A
	30	Int.	□	MWS0245X30DB	81	82	118	3	A
2.50	1	Int.	●	MWS0250SB	12.2	13.2	74	3	A
	5	Int.	●	MWS0250LB	28	29	74	3	A
	12	Int.	●	MWS0250XB	38	39	74	3	A
	20	Int.	●	MWS0250X20DB	58	59	94	3	A
	25	Int.	●	MWS0250X25DB	70	71	107	3	A
	30	Int.	●	MWS0250X30DB	83	84	118	3	A
2.55	1	Int.	●	MWS0255SB	12.6	12.6	81	3	B
	20	Int.	●	MWS0255X20DB	59	59	103	3	B
	25	Int.	●	MWS0255X25DB	71	71	117	3	B
	30	Int.	●	MWS0255X30DB	84	84	132	3	B

(Note) Please contact us for any geometry that is not in this catalogue (e.g. different diameters and lengths can be made to order).

- : Stock Standard.
- ★ : Stock Standard in Japan.
- : Non stock, produced to order only.

Drill Dia. D1 (mm)	Hole Depth (l/d)	Coolant (Int./Ext.)	Stock VP15TF	Order Number	Dimensions (mm)				Type
					L3	L2	L1	D4	
2.60	1	Int.	●	MWS0260SB	13.0	13.0	81	3	B
	5	Int.	●	MWS0260LB	33	33	81	3	B
	12	Int.	●	MWS0260XB	45	45	81	3	B
	20	Int.	●	MWS0260X20DB	60	60	103	3	B
	25	Int.	●	MWS0260X25DB	73	73	117	3	B
	30	Int.	●	MWS0260X30DB	86	86	132	3	B
2.65	1	Int.	●	MWS0265SB	13.2	13.2	81	3	B
	20	Int.	□	MWS0265X20DB	61	61	103	3	B
	25	Int.	□	MWS0265X25DB	74	74	117	3	B
	30	Int.	□	MWS0265X30DB	87	87	132	3	B
2.70	1	Int.	●	MWS0270SB	13.4	13.4	81	3	B
	5	Int.	●	MWS0270LB	33	33	81	3	B
	12	Int.	●	MWS0270XB	45	45	81	3	B
	20	Int.	●	MWS0270X20DB	62	62	103	3	B
	25	Int.	●	MWS0270X25DB	76	76	117	3	B
	30	Int.	●	MWS0270X30DB	89	89	132	3	B
2.75	1	Int.	●	MWS0275SB	13.6	13.6	81	3	B
	20	Int.	□	MWS0275X20DB	63	63	103	3	B
	25	Int.	□	MWS0275X25DB	77	77	117	3	B
	30	Int.	□	MWS0275X30DB	91	91	132	3	B

Drill Dia. D1 (mm)	Hole Depth (l/d)	Coolant (Int./Ext.)	Stock VP15TF	Order Number	Dimensions (mm)				Type
					L3	L2	L1	D4	
2.80	1	Int.	●	MWS0280SB	14.0	14.0	81	3	B
	5	Int.	●	MWS0280LB	33	33	81	3	B
	12	Int.	●	MWS0280XB	45	45	81	3	B
	20	Int.	●	MWS0280X20DB	64	64	103	3	B
	25	Int.	●	MWS0280X25DB	78	78	117	3	B
	30	Int.	●	MWS0280X30DB	92	92	132	3	B
	2.85	1	Int.	□	MWS0285SB	14.2	14.2	81	3
20		Int.	□	MWS0285X20DB	66	66	103	3	B
25		Int.	□	MWS0285X25DB	80	80	117	3	B
30		Int.	□	MWS0285X30DB	94	94	132	3	B
2.90	1	Int.	●	MWS0290SB	14.4	14.4	81	3	B
	5	Int.	●	MWS0290LB	33	33	81	3	B
	12	Int.	●	MWS0290XB	45	45	81	3	B
	20	Int.	●	MWS0290X20DB	67	67	103	3	B
	25	Int.	●	MWS0290X25DB	81	81	117	3	B
	30	Int.	●	MWS0290X30DB	96	96	132	3	B
2.95	1	Int.	●	MWS0295SB	14.6	14.6	81	3	B
	20	Int.	□	MWS0295X20DB	68	68	103	3	B
	25	Int.	□	MWS0295X25DB	83	83	117	3	B
	30	Int.	●	MWS0295X30DB	97	97	132	3	B

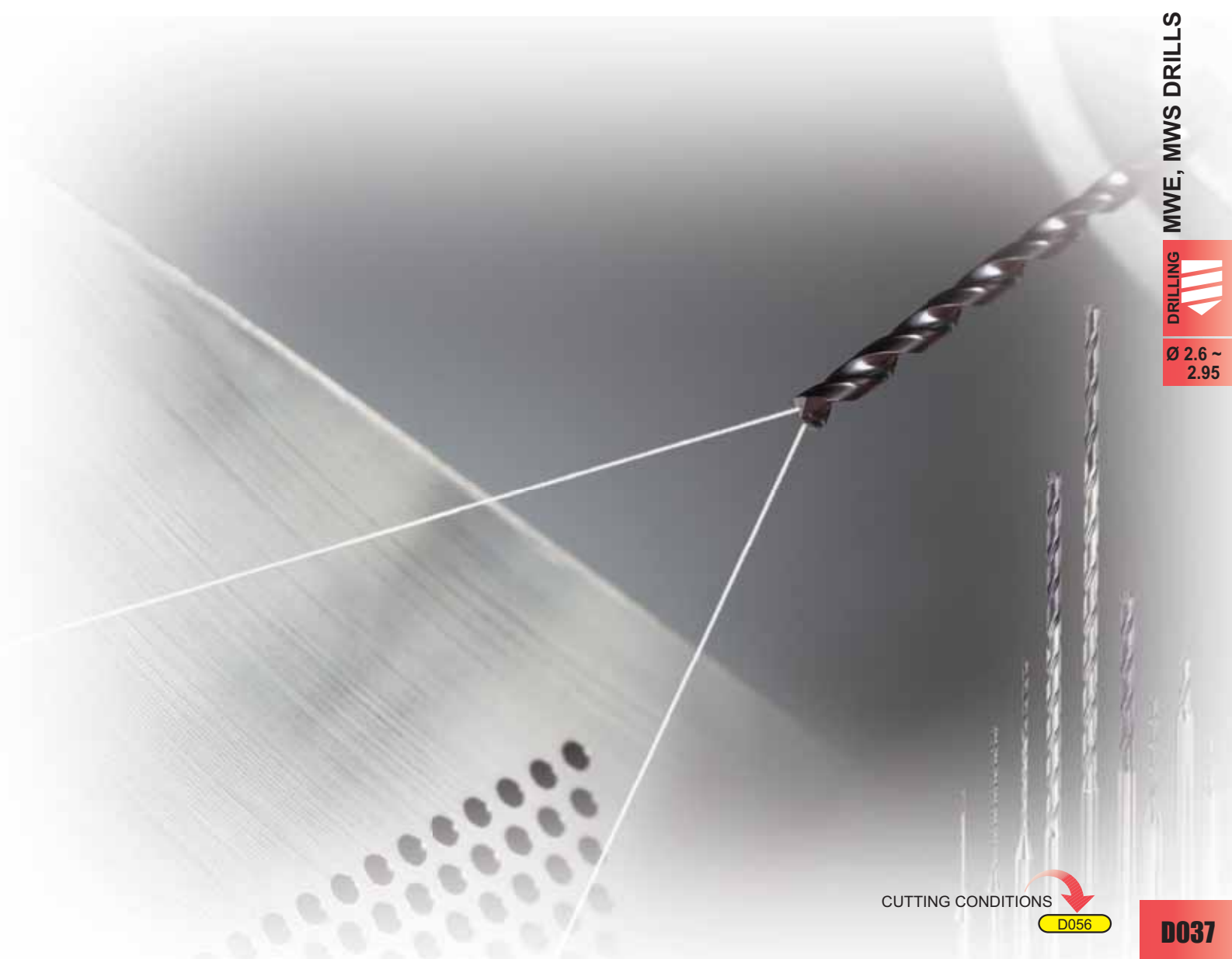

MWE, MWS DRILLS



Ø 2.6 ~ 2.95

CUTTING CONDITIONS

D056

D037

DRILLING (SOLID CARBIDE)

MWE, MWS

- Suitable for high efficiency and high accuracy drilling over a wide variety of materials from general steel to difficult-to-cut materials.
- Suitable for low to high speed cutting. Possible to use in the range of HSS cutting.



P	M	K	S	N	H
✓	✓	✓	✓	✓	✓

D1(h8)	D1 ≤ 3.0	3.0 < D1 ≤ 6.0	6.0 < D1 ≤ 10.0	10.0 < D1 ≤ 18.0	18.0 < D1 ≤ 30.0
Tolerance	0 -0.014	0 -0.018	0 -0.022	0 -0.027	0 -0.033

MWE (External coolant)



VP15TF

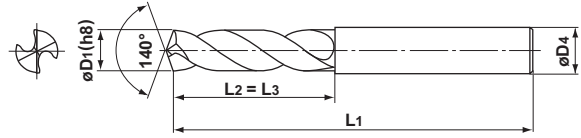

MWS (Internal coolant)



VP15TF

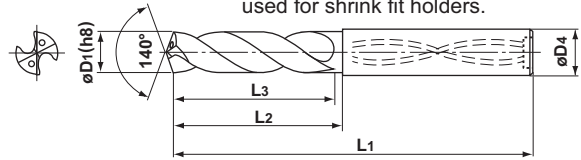

● The MWS-MB/LB/XB/X8DB type can be used for shrink fit holders.

(Note) MWS type bigger than $\phi 5.0$ have a recess in the end face.

Drill Dia. D1 (mm)	Hole Depth (l/d)	Coolant (Int./Ext.)	Stock VP15TF	Order Number	Dimensions (mm)			
					L3	L2	L1	D4
3.0	2	Ext.	●	MWE0300SA	16	16	55	3.0
	3	Ext.	●	MWE0300MA	21	21	60	3.0
	3	Int.	●	MWS0300MB	24	24	72	3.0
	5	Int.	●	MWS0300LB	33	33	81	3.0
	8	Int.	★	MWS0300X8DB	35	35	81	3.0
3.1	2	Ext.	●	MWE0310SA	18	18	55	3.1
	3	Ext.	●	MWE0310MA	24	24	60	3.1
	3	Int.	●	MWS0310MB	28	28	76	4.0
	5	Int.	●	MWS0310LB	39	39	87	4.0
	8	Int.	★	MWS0310X8DB	41	41	87	4.0
3.2	2	Ext.	●	MWE0320SA	18	18	55	3.2
	3	Ext.	●	MWE0320MA	24	24	60	3.2
	3	Int.	●	MWS0320MB	28	28	76	4.0
	5	Int.	●	MWS0320LB	39	39	87	4.0
	8	Int.	★	MWS0320X8DB	41	41	87	4.0
3.3	2	Ext.	●	MWE0330SA	18	18	55	3.3
	3	Ext.	●	MWE0330MA	24	24	60	3.3
	3	Int.	●	MWS0330MB	28	28	76	4.0
	5	Int.	●	MWS0330LB	39	39	87	4.0
	8	Int.	★	MWS0330X8DB	41	41	87	4.0
3.4	2	Ext.	●	MWE0340SA	20	20	55	3.4
	3	Ext.	●	MWE0340MA	24	24	60	3.4
	3	Int.	●	MWS0340MB	28	28	76	4.0
	5	Int.	●	MWS0340LB	39	39	87	4.0
	8	Int.	★	MWS0340X8DB	41	41	87	4.0
3.5	2	Ext.	●	MWE0350SA	20	20	55	3.5
	3	Ext.	●	MWE0350MA	24	24	60	3.5
	3	Int.	●	MWS0350MB	28	28	76	4.0
	5	Int.	●	MWS0350LB	39	39	87	4.0
	8	Int.	★	MWS0350X8DB	41	41	87	4.0
3.6	2	Ext.	●	MWE0360SA	20	20	55	3.6
	3	Ext.	●	MWE0360MA	27	27	60	3.6
	3	Int.	●	MWS0360MB	32	32	80	4.0
	5	Int.	●	MWS0360LB	44	44	92	4.0
	8	Int.	★	MWS0360X8DB	46	46	92	4.0

Drill Dia. D1 (mm)	Hole Depth (l/d)	Coolant (Int./Ext.)	Stock VP15TF	Order Number	Dimensions (mm)			
					L3	L2	L1	D4
3.7	2	Ext.	●	MWE0370SA	20	20	55	3.7
	3	Ext.	●	MWE0370MA	27	27	60	3.7
	3	Int.	●	MWS0370MB	32	32	80	4.0
	5	Int.	●	MWS0370LB	44	44	92	4.0
	8	Int.	★	MWS0370X8DB	46	46	92	4.0
3.8	2	Ext.	●	MWE0380SA	22	22	55	3.8
	3	Ext.	●	MWE0380MA	27	27	60	3.8
	3	Int.	●	MWS0380MB	32	32	80	4.0
	5	Int.	●	MWS0380LB	44	44	92	4.0
	8	Int.	★	MWS0380X8DB	46	46	92	4.0
3.9	2	Ext.	●	MWE0390SA	22	22	55	3.9
	3	Ext.	●	MWE0390MA	27	27	60	3.9
	3	Int.	●	MWS0390MB	32	32	80	4.0
	5	Int.	●	MWS0390LB	44	44	92	4.0
	8	Int.	★	MWS0390X8DB	46	46	92	4.0
4.0	2	Ext.	●	MWE0400SA	22	22	55	4.0
	3	Ext.	●	MWE0400MA	27	27	60	4.0
	3	Int.	●	MWS0400MB	32	32	80	4.0
	5	Int.	●	MWS0400LB	44	44	92	4.0
	8	Int.	★	MWS0400X8DB	46	46	92	4.0
4.1	2	Ext.	●	MWE0410SA	22	22	55	4.1
	3	Ext.	●	MWE0410MA	29	29	63	4.1
	3	Int.	●	MWS0410MB	36	36	86	5.0
	5	Int.	●	MWS0410LB	50	50	100	5.0
	8	Int.	★	MWS0410X8DB	52	52	100	5.0
4.2	2	Ext.	●	MWE0420SA	22	22	55	4.2
	3	Ext.	●	MWE0420MA	29	29	63	4.2
	3	Int.	●	MWS0420MB	36	36	86	5.0
	5	Int.	●	MWS0420LB	50	50	100	5.0
	8	Int.	★	MWS0420X8DB	52	52	100	5.0
4.3	2	Ext.	●	MWE0430SA	24	24	58	4.3
	3	Ext.	●	MWE0430MA	29	29	63	4.3
	3	Int.	●	MWS0430MB	36	36	86	5.0
	5	Int.	●	MWS0430LB	50	50	100	5.0
	8	Int.	★	MWS0430X8DB	52	52	100	5.0

(Note) Please contact us for any geometry that is not in this catalogue (e.g. different diameters and lengths can be made to order).

- : Stock Standard.
- ★ : Stock Standard in Japan.
- : Non stock, produced to order only.

Drill Dia. D1 (mm)	Hole Depth (l/d)	Coolant (Int./Ext.)	Stock VP15TF	Order Number	Dimensions (mm)			
					L3	L2	L1	D4
4.4	2	Ext.	●	MWE0440SA	24	24	58	4.4
	3	Ext.	●	MWE0440MA	29	29	63	4.4
	3	Int.	●	MWS0440MB	36	36	86	5.0
	5	Int.	●	MWS0440LB	50	50	100	5.0
	8	Int.	★	MWS0440X8DB	52	52	100	5.0
4.5	2	Ext.	●	MWE0450SA	24	24	58	4.5
	3	Ext.	●	MWE0450MA	29	29	63	4.5
	3	Int.	●	MWS0450MB	36	36	86	5.0
	5	Int.	●	MWS0450LB	50	50	100	5.0
	8	Int.	★	MWS0450X8DB	52	52	100	5.0
4.6	2	Ext.	●	MWE0460SA	24	24	58	4.6
	3	Ext.	●	MWE0460MA	32	32	68	4.6
	3	Int.	●	MWS0460MB	40	40	90	5.0
	5	Int.	●	MWS0460LB	55	55	105	5.0
	8	Int.	★	MWS0460X8DB	57	57	105	5.0
4.7	2	Ext.	●	MWE0470SA	24	24	58	4.7
	3	Ext.	●	MWE0470MA	32	32	68	4.7
	3	Int.	●	MWS0470MB	40	40	90	5.0
	5	Int.	●	MWS0470LB	55	55	105	5.0
	8	Int.	★	MWS0470X8DB	57	57	105	5.0
4.8	2	Ext.	●	MWE0480SA	26	26	62	4.8
	3	Ext.	●	MWE0480MA	32	32	68	4.8
	3	Int.	●	MWS0480MB	40	40	90	5.0
	5	Int.	●	MWS0480LB	55	55	105	5.0
	8	Int.	★	MWS0480X8DB	57	57	105	5.0
4.9	2	Ext.	●	MWE0490SA	26	26	62	4.9
	3	Ext.	●	MWE0490MA	32	32	68	4.9
	3	Int.	●	MWS0490MB	40	40	90	5.0
	5	Int.	●	MWS0490LB	55	55	105	5.0
	8	Int.	★	MWS0490X8DB	57	57	105	5.0
5.0	2	Ext.	●	MWE0500SA	26	26	62	5.0
	3	Ext.	●	MWE0500MA	32	32	68	5.0
	3	Int.	●	MWS0500MB	27.5	30	82	6.0
	5	Int.	●	MWS0500LB	44	48	100	6.0
	8	Int.	★	MWS0500X8DB	57	57	105	5.0
5.1	2	Ext.	●	MWE0510SA	26	26	62	5.1
	3	Ext.	●	MWE0510MA	34	34	72	5.1
	3	Int.	●	MWS0510MB	27.5	30	82	6.0
	5	Int.	●	MWS0510LB	44	48	100	6.0
	8	Int.	★	MWS0510X8DB	61	66	118	6.0
5.2	2	Ext.	●	MWE0520SA	26	26	62	5.2
	3	Ext.	●	MWE0520MA	34	34	72	5.2
	3	Int.	●	MWS0520MB	27.5	30	82	6.0
	5	Int.	●	MWS0520LB	44	48	100	6.0
	8	Int.	★	MWS0520X8DB	61	66	118	6.0
5.3	2	Ext.	●	MWE0530SA	26	26	62	5.3
	3	Ext.	●	MWE0530MA	34	34	72	5.3
	3	Int.	●	MWS0530MB	27.5	30	82	6.0
	5	Int.	●	MWS0530LB	44	48	100	6.0
	8	Int.	★	MWS0530X8DB	61	66	118	6.0

Drill Dia. D1 (mm)	Hole Depth (l/d)	Coolant (Int./Ext.)	Stock VP15TF	Order Number	Dimensions (mm)			
					L3	L2	L1	D4
5.4	2	Ext.	●	MWE0540SA	28	28	66	5.4
	3	Ext.	●	MWE0540MA	34	34	72	5.4
	3	Int.	●	MWS0540MB	27.5	30	82	6.0
	5	Int.	●	MWS0540LB	44	48	100	6.0
	8	Int.	★	MWS0540X8DB	61	66	118	6.0
5.5	2	Ext.	●	MWE0550SA	28	28	66	5.5
	3	Ext.	●	MWE0550MA	34	34	72	5.5
	3	Int.	●	MWS0550MB	27.5	30	82	6.0
	5	Int.	●	MWS0550LB	44	48	100	6.0
	8	Int.	★	MWS0550X8DB	61	66	118	6.0
5.6	2	Ext.	●	MWE0560SA	28	28	66	5.6
	3	Ext.	●	MWE0560MA	36	36	74	5.6
	3	Int.	●	MWS0560MB	30	30	82	6.0
	5	Int.	●	MWS0560LB	48	48	100	6.0
	8	Int.	★	MWS0560X8DB	66	66	118	6.0
5.7	2	Ext.	●	MWE0570SA	28	28	66	5.7
	3	Ext.	●	MWE0570MA	36	36	74	5.7
	3	Int.	●	MWS0570MB	30	30	82	6.0
	5	Int.	●	MWS0570LB	48	48	100	6.0
	8	Int.	★	MWS0570X8DB	66	66	118	6.0
5.8	2	Ext.	●	MWE0580SA	28	28	66	5.8
	3	Ext.	●	MWE0580MA	36	36	74	5.8
	3	Int.	●	MWS0580MB	30	30	82	6.0
	5	Int.	●	MWS0580LB	48	48	100	6.0
	8	Int.	★	MWS0580X8DB	66	66	118	6.0
5.9	2	Ext.	●	MWE0590SA	28	28	66	5.9
	3	Ext.	●	MWE0590MA	36	36	74	5.9
	3	Int.	●	MWS0590MB	30	30	82	6.0
	5	Int.	●	MWS0590LB	48	48	100	6.0
	8	Int.	★	MWS0590X8DB	66	66	118	6.0
6.0	2	Ext.	●	MWE0600SA	28	28	66	6.0
	3	Ext.	●	MWE0600MA	41	41	81	6.0
	3	Int.	●	MWS0600MB	30	30	82	6.0
	5	Int.	●	MWS0600LB	48	48	100	6.0
	8	Int.	★	MWS0600X8DB	66	66	118	6.0
6.1	2	Ext.	●	MWE0610SA	31	31	70	6.1
	3	Ext.	●	MWE0610MA	41	41	81	6.1
	3	Int.	●	MWS0610MB	32.5	35	88	7.0
	5	Int.	●	MWS0610LB	52	56	109	7.0
	8	Int.	★	MWS0610X8DB	72	77	130	7.0
6.2	2	Ext.	●	MWE0620SA	31	31	70	6.2
	3	Ext.	●	MWE0620MA	41	41	81	6.2
	3	Int.	●	MWS0620MB	32.5	35	88	7.0
	5	Int.	●	MWS0620LB	52	56	109	7.0
	8	Int.	★	MWS0620X8DB	72	77	130	7.0
6.3	2	Ext.	●	MWE0630SA	31	31	70	6.3
	3	Ext.	●	MWE0630MA	41	41	81	6.3
	3	Int.	●	MWS0630MB	32.5	35	88	7.0
	5	Int.	●	MWS0630LB	52	56	109	7.0
	8	Int.	★	MWS0630X8DB	72	77	130	7.0

MWE, MWS DRILLS



CUTTING CONDITIONS

D056

D039

DRILLING (SOLID CARBIDE)

MWE, MWS

- Suitable for high efficiency and high accuracy drilling over a wide variety of materials from general steel to difficult-to-cut materials.
- Suitable for low to high speed cutting. Possible to use in the range of HSS cutting.



P	M	K	S	N	H
✓	✓	✓	✓	✓	✓

MWE (External coolant)



VP15TF

D1(h8)	D1≤3.0	3.0<D1≤6.0	6.0<D1≤10.0	10.0<D1≤18.0	18.0<D1≤30.0
Tolerance	0 -0.014	0 -0.018	0 -0.022	0 -0.027	0 -0.033

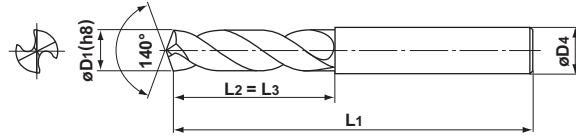

MWS (Internal coolant)



VP15TF

- The MWS-MB/LB/XB/X8DB type can be used for shrink fit holders.

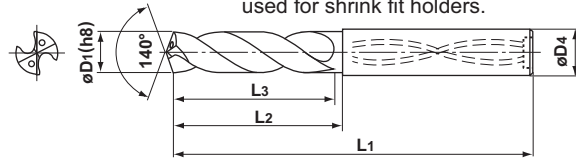

(Note) MWS type bigger than $\phi 5.0$ have a recess in the end face.

Drill Dia. D1 (mm)	Hole Depth (l/d)	Coolant (Int./Ext.)	Stock VP15TF	Order Number	Dimensions (mm)			
					L3	L2	L1	D4
6.4	2	Ext.	●	MWE0640SA	31	31	70	6.4
	3	Ext.	●	MWE0640MA	41	41	81	6.4
	3	Int.	●	MWS0640MB	32.5	35	88	7.0
	5	Int.	●	MWS0640LB	52	56	109	7.0
	8	Int.	★	MWS0640X8DB	72	77	130	7.0
6.5	2	Ext.	●	MWE0650SA	31	31	70	6.5
	3	Ext.	●	MWE0650MA	41	41	81	6.5
	3	Int.	●	MWS0650MB	32.5	35	88	7.0
	5	Int.	●	MWS0650LB	52	56	109	7.0
	8	Int.	★	MWS0650X8DB	72	77	130	7.0
6.6	2	Ext.	●	MWE0660SA	31	31	70	6.6
	3	Ext.	●	MWE0660MA	43	43	83	6.6
	3	Int.	●	MWS0660MB	35	35	88	7.0
	5	Int.	●	MWS0660LB	56	56	109	7.0
	8	Int.	★	MWS0660X8DB	77	77	130	7.0
6.7	2	Ext.	●	MWE0670SA	31	31	70	6.7
	3	Ext.	●	MWE0670MA	43	43	83	6.7
	3	Int.	●	MWS0670MB	35	35	88	7.0
	5	Int.	●	MWS0670LB	56	56	109	7.0
	8	Int.	★	MWS0670X8DB	77	77	130	7.0
6.8	2	Ext.	●	MWE0680SA	34	34	74	6.8
	3	Ext.	●	MWE0680MA	43	43	83	6.8
	3	Int.	●	MWS0680MB	35	35	88	7.0
	5	Int.	●	MWS0680LB	56	56	109	7.0
	8	Int.	★	MWS0680X8DB	77	77	130	7.0
6.9	2	Ext.	●	MWE0690SA	34	34	74	6.9
	3	Ext.	●	MWE0690MA	43	43	83	6.9
	3	Int.	●	MWS0690MB	35	35	88	7.0
	5	Int.	●	MWS0690LB	56	56	109	7.0
	8	Int.	★	MWS0690X8DB	77	77	130	7.0
7.0	2	Ext.	●	MWE0700SA	34	34	74	7.0
	3	Ext.	●	MWE0700MA	43	43	83	7.0
	3	Int.	●	MWS0700MB	35	35	88	7.0
	5	Int.	●	MWS0700LB	56	56	109	7.0
	8	Int.	★	MWS0700X8DB	77	77	130	7.0

Drill Dia. D1 (mm)	Hole Depth (l/d)	Coolant (Int./Ext.)	Stock VP15TF	Order Number	Dimensions (mm)			
					L3	L2	L1	D4
7.1	2	Ext.	●	MWE0710SA	34	34	74	7.1
	3	Ext.	●	MWE0710MA	45	45	87	7.1
	3	Int.	●	MWS0710MB	37.5	40	94	8.0
	5	Int.	●	MWS0710LB	60	64	118	8.0
	8	Int.	★	MWS0710X8DB	83	88	142	8.0
7.2	2	Ext.	●	MWE0720SA	34	34	74	7.2
	3	Ext.	●	MWE0720MA	45	45	87	7.2
	3	Int.	●	MWS0720MB	37.5	40	94	8.0
	5	Int.	●	MWS0720LB	60	64	118	8.0
	8	Int.	★	MWS0720X8DB	83	88	142	8.0
7.3	2	Ext.	●	MWE0730SA	34	34	74	7.3
	3	Ext.	●	MWE0730MA	45	45	87	7.3
	3	Int.	●	MWS0730MB	37.5	40	94	8.0
	5	Int.	●	MWS0730LB	60	64	118	8.0
	8	Int.	★	MWS0730X8DB	83	88	142	8.0
7.4	2	Ext.	●	MWE0740SA	34	34	74	7.4
	3	Ext.	●	MWE0740MA	45	45	87	7.4
	3	Int.	●	MWS0740MB	37.5	40	94	8.0
	5	Int.	●	MWS0740LB	60	64	118	8.0
	8	Int.	★	MWS0740X8DB	83	88	142	8.0
7.5	2	Ext.	●	MWE0750SA	34	34	74	7.5
	3	Ext.	●	MWE0750MA	45	45	87	7.5
	3	Int.	●	MWS0750MB	37.5	40	94	8.0
	5	Int.	●	MWS0750LB	60	64	118	8.0
	8	Int.	★	MWS0750X8DB	83	88	142	8.0
7.6	2	Ext.	●	MWE0760SA	37	37	79	7.6
	3	Ext.	●	MWE0760MA	48	48	90	7.6
	3	Int.	●	MWS0760MB	40	40	94	8.0
	5	Int.	●	MWS0760LB	64	64	118	8.0
	8	Int.	★	MWS0760X8DB	88	88	142	8.0
7.7	2	Ext.	●	MWE0770SA	37	37	79	7.7
	3	Ext.	●	MWE0770MA	48	48	90	7.7
	3	Int.	●	MWS0770MB	40	40	94	8.0
	5	Int.	●	MWS0770LB	64	64	118	8.0
	8	Int.	★	MWS0770X8DB	88	88	142	8.0

(Note) Please contact us for any geometry that is not in this catalogue (e.g. different diameters and lengths can be made to order).

DRILLING | MWE, MWS DRILLS

DRILLING | MWE, MWS DRILLS
 $\phi 6.4 \sim 7.7$

- : Stock Standard.
- ★ : Stock Standard in Japan.
- : Non stock, produced to order only.

Drill Dia. D1 (mm)	Hole Depth (l/d)	Coolant (Int./Ext.)	Stock VP15TF	Order Number	Dimensions (mm)			
					L3	L2	L1	D4
7.8	2	Ext.	●	MWE0780SA	37	37	79	7.8
	3	Ext.	●	MWE0780MA	48	48	90	7.8
	3	Int.	●	MWS0780MB	40	40	94	8.0
	5	Int.	●	MWS0780LB	64	64	118	8.0
	8	Int.	★	MWS0780X8DB	88	88	142	8.0
7.9	2	Ext.	●	MWE0790SA	37	37	79	7.9
	3	Ext.	●	MWE0790MA	48	48	90	7.9
	3	Int.	●	MWS0790MB	40	40	94	8.0
	5	Int.	●	MWS0790LB	64	64	118	8.0
	8	Int.	★	MWS0790X8DB	88	88	142	8.0
8.0	2	Ext.	●	MWE0800SA	37	37	79	8.0
	3	Ext.	●	MWE0800MA	48	48	90	8.0
	3	Int.	●	MWS0800MB	40	40	94	8.0
	5	Int.	●	MWS0800LB	64	64	118	8.0
	8	Int.	★	MWS0800X8DB	88	88	142	8.0
8.1	2	Ext.	●	MWE0810SA	37	37	79	8.1
	3	Ext.	●	MWE0810MA	53	53	96	8.1
	3	Int.	●	MWS0810MB	42.5	45	100	9.0
	5	Int.	●	MWS0810LB	68	72	127	9.0
	8	Int.	★	MWS0810X8DB	94	99	154	9.0
8.2	2	Ext.	●	MWE0820SA	37	37	79	8.2
	3	Ext.	●	MWE0820MA	53	53	96	8.2
	3	Int.	●	MWS0820MB	42.5	45	100	9.0
	5	Int.	●	MWS0820LB	68	72	127	9.0
	8	Int.	★	MWS0820X8DB	94	99	154	9.0
8.3	2	Ext.	●	MWE0830SA	37	37	79	8.3
	3	Ext.	●	MWE0830MA	53	53	96	8.3
	3	Int.	●	MWS0830MB	42.5	45	100	9.0
	5	Int.	●	MWS0830LB	68	72	127	9.0
	8	Int.	★	MWS0830X8DB	94	99	154	9.0
8.4	2	Ext.	●	MWE0840SA	37	37	79	8.4
	3	Ext.	●	MWE0840MA	53	53	96	8.4
	3	Int.	●	MWS0840MB	42.5	45	100	9.0
	5	Int.	●	MWS0840LB	68	72	127	9.0
	8	Int.	★	MWS0840X8DB	94	99	154	9.0
8.5	2	Ext.	●	MWE0850SA	37	37	79	8.5
	3	Ext.	●	MWE0850MA	53	53	96	8.5
	3	Int.	●	MWS0850MB	42.5	45	100	9.0
	5	Int.	●	MWS0850LB	68	72	127	9.0
	8	Int.	★	MWS0850X8DB	94	99	154	9.0
8.6	2	Ext.	●	MWE0860SA	40	40	84	8.6
	3	Ext.	●	MWE0860MA	55	55	98	8.6
	3	Int.	●	MWS0860MB	45	45	100	9.0
	5	Int.	●	MWS0860LB	72	72	127	9.0
	8	Int.	★	MWS0860X8DB	99	99	154	9.0
8.7	2	Ext.	●	MWE0870SA	40	40	84	8.7
	3	Ext.	●	MWE0870MA	55	55	98	8.7
	3	Int.	●	MWS0870MB	45	45	100	9.0
	5	Int.	●	MWS0870LB	72	72	127	9.0
	8	Int.	★	MWS0870X8DB	99	99	154	9.0

Drill Dia. D1 (mm)	Hole Depth (l/d)	Coolant (Int./Ext.)	Stock VP15TF	Order Number	Dimensions (mm)			
					L3	L2	L1	D4
8.8	2	Ext.	●	MWE0880SA	40	40	84	8.8
	3	Ext.	●	MWE0880MA	55	55	98	8.8
	3	Int.	●	MWS0880MB	45	45	100	9.0
	5	Int.	●	MWS0880LB	72	72	127	9.0
	8	Int.	★	MWS0880X8DB	99	99	154	9.0
8.9	2	Ext.	●	MWE0890SA	40	50	84	8.9
	3	Ext.	●	MWE0890MA	55	55	98	8.9
	3	Int.	●	MWS0890MB	45	45	100	9.0
	5	Int.	●	MWS0890LB	72	72	127	9.0
	8	Int.	★	MWS0890X8DB	99	99	154	9.0
9.0	2	Ext.	●	MWE0900SA	40	40	84	9.0
	3	Ext.	●	MWE0900MA	55	55	98	9.0
	3	Int.	●	MWS0900MB	45	45	100	9.0
	5	Int.	●	MWS0900LB	72	72	127	9.0
	8	Int.	★	MWS0900X8DB	99	99	154	9.0
9.1	2	Ext.	●	MWE0910SA	40	40	84	9.1
	3	Ext.	●	MWE0910MA	58	58	102	9.1
	3	Int.	●	MWS0910MB	47.5	50	106	10.0
	5	Int.	●	MWS0910LB	76	80	136	10.0
	8	Int.	★	MWS0910X8DB	105	110	166	10.0
9.2	2	Ext.	●	MWE0920SA	40	40	84	9.2
	3	Ext.	●	MWE0920MA	58	58	102	9.2
	3	Int.	●	MWS0920MB	47.5	50	106	10.0
	5	Int.	●	MWS0920LB	76	80	136	10.0
	8	Int.	★	MWS0920X8DB	105	110	166	10.0
9.3	2	Ext.	●	MWE0930SA	40	40	84	9.3
	3	Ext.	●	MWE0930MA	58	58	102	9.3
	3	Int.	●	MWS0930MB	47.5	50	106	10.0
	5	Int.	●	MWS0930LB	76	80	136	10.0
	8	Int.	★	MWS0930X8DB	105	110	166	10.0
9.4	2	Ext.	●	MWE0940SA	40	40	84	9.4
	3	Ext.	●	MWE0940MA	58	58	102	9.4
	3	Int.	●	MWS0940MB	47.5	50	106	10.0
	5	Int.	●	MWS0940LB	76	80	136	10.0
	8	Int.	★	MWS0940X8DB	105	110	166	10.0
9.5	2	Ext.	●	MWE0950SA	40	40	84	9.5
	3	Ext.	●	MWE0950MA	58	58	102	9.5
	3	Int.	●	MWS0950MB	47.5	50	106	10.0
	5	Int.	●	MWS0950LB	76	80	136	10.0
	8	Int.	★	MWS0950X8DB	105	110	166	10.0
9.6	2	Ext.	●	MWE0960SA	43	43	89	9.6
	3	Ext.	●	MWE0960MA	60	60	105	9.6
	3	Int.	●	MWS0960MB	50	50	106	10.0
	5	Int.	●	MWS0960LB	80	80	136	10.0
	8	Int.	★	MWS0960X8DB	110	110	166	10.0
9.7	2	Ext.	●	MWE0970SA	43	43	89	9.7
	3	Ext.	●	MWE0970MA	60	60	105	9.7
	3	Int.	●	MWS0970MB	50	50	106	10.0
	5	Int.	●	MWS0970LB	80	80	136	10.0
	8	Int.	★	MWS0970X8DB	110	110	166	10.0

MWE, MWS DRILLS



CUTTING CONDITIONS

D056

D041

DRILLING (SOLID CARBIDE)

MWE, MWS

- Suitable for high efficiency and high accuracy drilling over a wide variety of materials from general steel to difficult-to-cut materials.
- Suitable for low to high speed cutting. Possible to use in the range of HSS cutting.



P ✓	M ✓	K ✓	S ✓	N ✓	H ✓
------------	------------	------------	------------	------------	------------

MWE (External coolant)



VP15TF

D1(h8)	D1 ≤ 3.0	3.0 < D1 ≤ 6.0	6.0 < D1 ≤ 10.0	10.0 < D1 ≤ 18.0	18.0 < D1 ≤ 30.0
Tolerance	0 -0.014	0 -0.018	0 -0.022	0 -0.027	0 -0.033

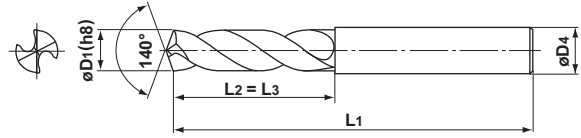

MWS (Internal coolant)



VP15TF

- The MWS-MB/LB/XB/X8DB type can be used for shrink fit holders.

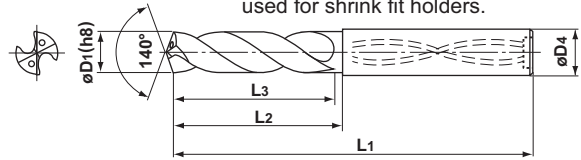

(Note) MWS type bigger than ϕ 5.0 have a recess in the end face.

Drill Dia. D1 (mm)	Hole Depth (l/d)	Coolant (Int./Ext.)	Stock VP15TF	Order Number	Dimensions (mm)			
					L3	L2	L1	D4
9.8	2	Ext.	●	MWE0980SA	43	43	89	9.8
	3	Ext.	●	MWE0980MA	60	60	105	9.8
	3	Int.	●	MWS0980MB	50	50	106	10.0
	5	Int.	●	MWS0980LB	80	80	136	10.0
	8	Int.	★	MWS0980X8DB	110	110	166	10.0
9.9	2	Ext.	●	MWE0990SA	43	43	89	9.9
	3	Ext.	●	MWE0990MA	60	60	105	9.9
	3	Int.	●	MWS0990MB	50	50	106	10.0
	5	Int.	●	MWS0990LB	80	80	136	10.0
	8	Int.	★	MWS0990X8DB	110	110	166	10.0
10.0	2	Ext.	●	MWE1000SA	43	43	89	10.0
	3	Ext.	●	MWE1000MA	60	60	105	10.0
	3	Int.	●	MWS1000MB	50	50	106	10.0
	5	Int.	●	MWS1000LB	80	80	136	10.0
	8	Int.	★	MWS1000X8DB	110	110	166	10.0
10.1	2	Ext.	●	MWE1010SA	43	43	89	10.1
	3	Ext.	●	MWE1010MA	66	66	112	10.1
	3	Int.	●	MWS1010MB	52.5	55	116	11.0
	5	Int.	●	MWS1010LB	84	88	149	11.0
	8	Int.	★	MWS1010X8DB	116	121	182	11.0
10.2	2	Ext.	●	MWE1020SA	43	43	89	10.2
	3	Ext.	●	MWE1020MA	66	66	112	10.2
	3	Int.	●	MWS1020MB	52.5	55	116	11.0
	5	Int.	●	MWS1020LB	84	88	149	11.0
	8	Int.	★	MWS1020X8DB	116	121	182	11.0
10.3	2	Ext.	●	MWE1030SA	43	43	89	3.6
	3	Ext.	●	MWE1030MA	66	66	112	3.6
	3	Int.	●	MWS1030MB	52.5	55	116	4.0
	5	Int.	●	MWS1030LB	84	88	149	4.0
	8	Int.	★	MWS1030X8DB	116	121	182	4.0
10.4	2	Ext.	●	MWE1040SA	43	43	89	10.4
	3	Ext.	●	MWE1040MA	66	66	112	10.4
	3	Int.	●	MWS1040MB	52.5	55	116	11.0
	5	Int.	●	MWS1040LB	84	88	149	11.0
	8	Int.	★	MWS1040X8DB	116	121	182	11.0

Drill Dia. D1 (mm)	Hole Depth (l/d)	Coolant (Int./Ext.)	Stock VP15TF	Order Number	Dimensions (mm)			
					L3	L2	L1	D4
10.5	2	Ext.	●	MWE1050SA	43	43	89	10.5
	3	Ext.	●	MWE1050MA	66	66	112	10.5
	3	Int.	●	MWS1050MB	52.5	55	116	11.0
	5	Int.	●	MWS1050LB	84	88	149	11.0
	8	Int.	★	MWS1050X8DB	116	121	182	11.0
10.6	2	Ext.	●	MWE1060SA	43	43	89	10.6
	3	Ext.	●	MWE1060MA	68	68	114	10.6
	3	Int.	●	MWS1060MB	55	55	116	11.0
	5	Int.	●	MWS1060LB	88	88	149	11.0
	8	Int.	★	MWS1060X8DB	121	121	182	11.0
10.7	2	Ext.	●	MWE1070SA	47	47	95	10.7
	3	Ext.	●	MWE1070MA	68	68	114	10.7
	3	Int.	●	MWS1070MB	55	55	116	11.0
	5	Int.	●	MWS1070LB	88	88	149	11.0
	8	Int.	★	MWS1070X8DB	121	121	182	11.0
10.8	2	Ext.	●	MWE1080SA	47	47	95	10.8
	3	Ext.	●	MWE1080MA	68	68	114	10.8
	3	Int.	●	MWS1080MB	55	55	116	11.0
	5	Int.	●	MWS1080LB	88	88	149	11.0
	8	Int.	★	MWS1080X8DB	121	121	182	11.0
10.9	2	Ext.	●	MWE1090SA	47	47	95	10.9
	3	Ext.	●	MWE1090MA	68	68	114	10.9
	3	Int.	●	MWS1090MB	55	55	116	11.0
	5	Int.	●	MWS1090LB	88	88	149	11.0
	8	Int.	★	MWS1090X8DB	121	121	182	11.0
11.0	2	Ext.	●	MWE1100SA	47	47	95	11.0
	3	Ext.	●	MWE1100MA	68	68	114	11.0
	3	Int.	●	MWS1100MB	55	55	116	11.0
	5	Int.	●	MWS1100LB	88	88	149	11.0
	8	Int.	★	MWS1100X8DB	121	121	182	11.0
11.1	2	Ext.	●	MWE1110SA	47	47	95	11.1
	3	Ext.	●	MWE1110MA	71	71	118	11.1
	3	Int.	●	MWS1110MB	57.5	60	122	12.0
	5	Int.	●	MWS1110LB	92	96	158	12.0
	8	Int.	★	MWS1110X8DB	127	132	194	12.0

(Note) Please contact us for any geometry that is not in this catalogue (e.g. different diameters and lengths can be made to order).

- : Stock Standard.
- ★ : Stock Standard in Japan.
- : Non stock, produced to order only.

Drill Dia. D1 (mm)	Hole Depth (l/d)	Coolant (Int./Ext.)	Stock VP15TF	Order Number	Dimensions (mm)			
					L3	L2	L1	D4
11.2	2	Ext.	●	MWE1120SA	47	47	95	11.2
	3	Ext.	●	MWE1120MA	71	71	118	11.2
	3	Int.	●	MWS1120MB	57.5	60	122	12.0
	5	Int.	●	MWS1120LB	92	96	158	12.0
	8	Int.	★	MWS1120X8DB	127	132	194	12.0
11.3	2	Ext.	●	MWE1130SA	47	47	95	11.3
	3	Ext.	●	MWE1130MA	71	71	118	11.3
	3	Int.	●	MWS1130MB	57.5	60	122	12.0
	5	Int.	●	MWS1130LB	92	96	158	12.0
	8	Int.	★	MWS1130X8DB	127	132	194	12.0
11.4	2	Ext.	●	MWE1140SA	47	47	95	11.4
	3	Ext.	●	MWE1140MA	71	71	118	11.4
	3	Int.	●	MWS1140MB	57.5	60	122	12.0
	5	Int.	●	MWS1140LB	92	96	158	12.0
	8	Int.	★	MWS1140X8DB	127	132	194	12.0
11.5	2	Ext.	●	MWE1150SA	47	47	95	11.5
	3	Ext.	●	MWE1150MA	71	71	118	11.5
	3	Int.	●	MWS1150MB	57.5	60	122	12.0
	5	Int.	●	MWS1150LB	92	96	158	12.0
	8	Int.	★	MWS1150X8DB	127	132	194	12.0
11.6	2	Ext.	●	MWE1160SA	47	47	95	11.6
	3	Ext.	●	MWE1160MA	73	73	121	11.6
	3	Int.	●	MWS1160MB	60	60	122	12.0
	5	Int.	●	MWS1160LB	96	96	158	12.0
	8	Int.	★	MWS1160X8DB	132	132	194	12.0
11.7	2	Ext.	●	MWE1170SA	47	47	95	11.7
	3	Ext.	●	MWE1170MA	73	73	121	11.7
	3	Int.	●	MWS1170MB	60	60	122	12.0
	5	Int.	●	MWS1170LB	96	96	158	12.0
	8	Int.	★	MWS1170X8DB	132	132	194	12.0
11.8	2	Ext.	●	MWE1180SA	47	47	95	11.8
	3	Ext.	●	MWE1180MA	73	73	121	11.8
	3	Int.	●	MWS1180MB	60	60	122	12.0
	5	Int.	●	MWS1180LB	96	96	158	12.0
	8	Int.	★	MWS1180X8DB	132	132	194	12.0
11.9	2	Ext.	●	MWE1190SA	51	51	102	11.9
	3	Ext.	●	MWE1190MA	73	73	121	11.9
	3	Int.	●	MWS1190MB	60	60	122	12.0
	5	Int.	●	MWS1190LB	96	96	158	12.0
	8	Int.	★	MWS1190X8DB	132	132	194	12.0
12.0	2	Ext.	●	MWE1200SA	51	51	102	12.0
	3	Ext.	●	MWE1200MA	73	73	121	12.0
	3	Int.	●	MWS1200MB	60	60	122	12.0
	5	Int.	●	MWS1200LB	96	96	158	12.0
	8	Int.	★	MWS1200X8DB	132	132	194	12.0
12.1	2	Ext.	●	MWE1210SA	51	51	102	12.1
	3	Ext.	●	MWE1210MA	76	76	135	12.1
	3	Int.	●	MWS1210MB	62.5	65	128	13.0
	5	Int.	●	MWS1210LB	100	104	167	13.0
	8	Int.	□	MWS1210X8DB	138	143	206	13.0

Drill Dia. D1 (mm)	Hole Depth (l/d)	Coolant (Int./Ext.)	Stock VP15TF	Order Number	Dimensions (mm)			
					L3	L2	L1	D4
12.2	2	Ext.	●	MWE1220SA	51	51	102	12.2
	3	Ext.	●	MWE1220MA	76	76	135	12.2
	3	Int.	●	MWS1220MB	62.5	65	128	13.0
	5	Int.	●	MWS1220LB	100	104	167	13.0
	8	Int.	□	MWS1220X8DB	138	143	206	13.0
12.3	2	Ext.	●	MWE1230SA	51	51	102	12.3
	3	Ext.	●	MWE1230MA	76	76	135	12.3
	3	Int.	●	MWS1230MB	62.5	65	128	13.0
	5	Int.	●	MWS1230LB	100	104	167	13.0
	8	Int.	□	MWS1230X8DB	138	143	206	13.0
12.4	2	Ext.	●	MWE1240SA	51	51	102	12.4
	3	Ext.	●	MWE1240MA	76	76	135	12.4
	3	Int.	●	MWS1240MB	62.5	65	128	13.0
	5	Int.	●	MWS1240LB	100	104	167	13.0
	8	Int.	□	MWS1240X8DB	138	143	206	13.0
12.5	2	Ext.	●	MWE1250SA	51	51	102	12.5
	3	Ext.	●	MWE1250MA	76	76	135	12.5
	3	Int.	●	MWS1250MB	62.5	65	128	13.0
	5	Int.	●	MWS1250LB	100	104	167	13.0
	8	Int.	★	MWS1250X8DB	138	143	206	13.0
12.6	2	Ext.	●	MWE1260SA	51	51	102	12.6
	3	Ext.	●	MWE1260MA	78	78	137	12.6
	3	Int.	●	MWS1260MB	65	65	128	13.0
	5	Int.	●	MWS1260LB	104	104	167	13.0
	8	Int.	□	MWS1260X8DB	143	143	206	13.0
12.7	2	Ext.	●	MWE1270SA	51	51	102	12.7
	3	Ext.	●	MWE1270MA	78	78	137	12.7
	3	Int.	●	MWS1270MB	65	65	128	13.0
	5	Int.	●	MWS1270LB	104	104	167	13.0
	8	Int.	□	MWS1270X8DB	143	143	206	13.0
12.8	2	Ext.	●	MWE1280SA	51	51	102	12.8
	3	Ext.	●	MWE1280MA	78	78	137	12.8
	3	Int.	●	MWS1280MB	65	65	128	13.0
	5	Int.	●	MWS1280LB	104	104	167	13.0
	8	Int.	□	MWS1280X8DB	143	143	206	13.0
12.9	2	Ext.	●	MWE1290SA	51	51	102	12.9
	3	Ext.	●	MWE1290MA	78	78	137	12.9
	3	Int.	●	MWS1290MB	65	65	128	13.0
	5	Int.	●	MWS1290LB	104	104	167	13.0
	8	Int.	□	MWS1290X8DB	143	143	206	13.0
13.0	2	Ext.	●	MWE1300SA	51	51	102	13.0
	3	Ext.	●	MWE1300MA	78	78	137	13.0
	3	Int.	●	MWS1300MB	65	65	128	13.0
	5	Int.	●	MWS1300LB	104	104	167	13.0
	8	Int.	★	MWS1300X8DB	143	143	206	13.0
13.1	2	Ext.	●	MWE1310SA	51	51	102	13.1
	3	Ext.	●	MWE1310MA	84	84	144	13.1
	3	Int.	●	MWS1310MB	67.5	70	134	14.0
	5	Int.	●	MWS1310LB	108	112	176	14.0
	8	Int.	□	MWS1310X8DB	149	154	218	14.0

MWE, MWS DRILLS



Ø 11.2 ~ 13.1

CUTTING CONDITIONS

D056

D043

DRILLING (SOLID CARBIDE)

MWE, MWS

- Suitable for high efficiency and high accuracy drilling over a wide variety of materials from general steel to difficult-to-cut materials.
- Suitable for low to high speed cutting. Possible to use in the range of HSS cutting.



P	M	K	S	N	H
✓	✓	✓	✓	✓	✓

MWE (External coolant)



VP15TF

D1(h8)	D1 ≤ 3.0	3.0 < D1 ≤ 6.0	6.0 < D1 ≤ 10.0	10.0 < D1 ≤ 18.0	18.0 < D1 ≤ 30.0
Tolerance	0 -0.014	0 -0.018	0 -0.022	0 -0.027	0 -0.033

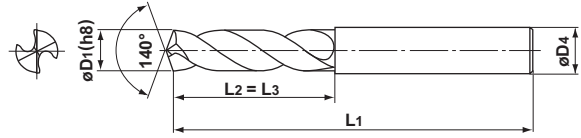

MWS (Internal coolant)



VP15TF

- The MWS-MB/LB/XB/X8DB type can be used for shrink fit holders.

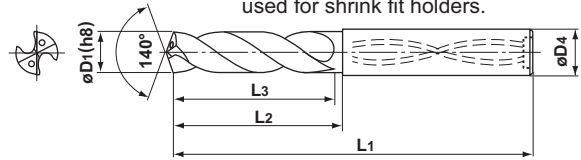

(Note) MWS type bigger than $\phi 5.0$ have a recess in the end face.

Drill Dia. D1 (mm)	Hole Depth (l/d)	Coolant (Int./Ext.)	Stock VP15TF	Order Number	Dimensions (mm)			
					L3	L2	L1	D4
13.2	2	Ext.	●	MWE1320SA	51	51	102	13.2
	3	Ext.	●	MWE1320MA	84	84	144	13.2
	3	Int.	●	MWS1320MB	67.5	70	134	14.0
	5	Int.	●	MWS1320LB	108	112	176	14.0
	8	Int.	□	MWS1320X8DB	149	154	218	14.0
13.3	2	Ext.	●	MWE1330SA	54	54	107	13.3
	3	Ext.	●	MWE1330MA	84	84	144	13.3
	3	Int.	●	MWS1330MB	67.5	70	134	14.0
	5	Int.	●	MWS1330LB	108	112	176	14.0
	8	Int.	□	MWS1330X8DB	149	154	218	14.0
13.4	2	Ext.	●	MWE1340SA	54	54	107	13.4
	3	Ext.	●	MWE1340MA	84	84	144	13.4
	3	Int.	●	MWS1340MB	67.5	70	134	14.0
	5	Int.	●	MWS1340LB	108	112	176	14.0
	8	Int.	□	MWS1340X8DB	149	154	218	14.0
13.5	2	Ext.	●	MWE1350SA	54	54	107	13.5
	3	Ext.	●	MWE1350MA	84	84	144	13.5
	3	Int.	●	MWS1350MB	67.5	70	134	14.0
	5	Int.	●	MWS1350LB	108	112	176	14.0
	8	Int.	★	MWS1350X8DB	149	154	218	14.0
13.6	2	Ext.	●	MWE1360SA	54	54	107	13.6
	3	Ext.	●	MWE1360MA	86	84	144	13.6
	3	Int.	●	MWS1360MB	70	70	134	14.0
	5	Int.	●	MWS1360LB	112	112	176	14.0
	8	Int.	□	MWS1360X8DB	154	154	218	14.0
13.7	2	Ext.	●	MWE1370SA	54	54	107	13.7
	3	Ext.	●	MWE1370MA	86	86	147	13.7
	3	Int.	●	MWS1370MB	70	70	134	14.0
	5	Int.	●	MWS1370LB	112	112	176	14.0
	8	Int.	□	MWS1370X8DB	154	154	218	14.0
13.8	2	Ext.	●	MWE1380SA	54	54	107	13.8
	3	Ext.	●	MWE1380MA	86	86	147	13.8
	3	Int.	●	MWS1380MB	70	70	134	14.0
	5	Int.	●	MWS1380LB	112	112	176	14.0
	8	Int.	□	MWS1380X8DB	154	154	218	14.0

Drill Dia. D1 (mm)	Hole Depth (l/d)	Coolant (Int./Ext.)	Stock VP15TF	Order Number	Dimensions (mm)			
					L3	L2	L1	D4
13.9	2	Ext.	●	MMWE1390SA	54	54	107	13.9
	3	Ext.	●	MWE1390MA	86	86	147	13.9
	3	Int.	●	MWS1390MB	70	70	134	14.0
	5	Int.	●	MWS1390LB	112	112	176	14.0
	8	Int.	□	MWS1390X8DB	154	154	218	14.0
14.0	2	Ext.	●	MWE1400SA	54	54	107	14.0
	3	Ext.	●	MWE1400MA	86	86	147	14.0
	3	Int.	●	MWS1400MB	70	70	134	14.0
	5	Int.	●	MWS1400LB	112	112	176	14.0
	8	Int.	★	MWS1400X8DB	154	154	218	14.0
14.1	2	Ext.	●	MWE1410SA	56	56	111	14.1
	3	Ext.	●	MWE1410MA	89	89	151	14.1
	3	Int.	●	MWS1410MB	72.5	75	140	15.0
	5	Int.	●	MWS1410LB	116	120	185	15.0
	8	Int.	□	MWS1410X8DB	160	165	225	15.0
14.2	2	Ext.	●	MWE1420SA	56	56	111	14.2
	3	Ext.	●	MWE1420MA	89	89	151	14.2
	3	Int.	●	MWS1420MB	72.5	75	140	15.0
	5	Int.	●	MWS1420LB	116	120	185	15.0
	8	Int.	★	MWS1420X8DB	160	165	225	15.0
14.3	2	Ext.	□	MWE1430SA	56	56	111	14.3
	3	Ext.	●	MWE1430MA	89	89	151	14.3
	3	Int.	●	MWS1430MB	72.5	75	140	15.0
	5	Int.	●	MWS1430LB	116	120	185	15.0
	8	Int.	□	MWS1430X8DB	160	165	225	15.0
14.4	2	Ext.	□	MWE1440SA	56	56	111	14.4
	3	Ext.	●	MWE1440MA	89	89	151	14.4
	3	Int.	●	MWS1440MB	72.5	75	140	15.0
	5	Int.	●	MWS1440LB	116	120	185	15.0
	8	Int.	□	MWS1440X8DB	160	165	225	15.0
14.5	2	Ext.	●	MWE1450SA	56	56	111	14.5
	3	Ext.	●	MWE1450MA	89	89	151	14.5
	3	Int.	●	MWS1450MB	72.5	75	140	15.0
	5	Int.	●	MWS1450LB	116	120	185	15.0
	8	Int.	★	MWS1450X8DB	160	165	225	15.0

(Note) Please contact us for any geometry that is not in this catalogue (e.g. different diameters and lengths can be made to order).

- : Stock Standard.
- ★ : Stock Standard in Japan.
- : Non stock, produced to order only.

Drill Dia. D1 (mm)	Hole Depth (l/d)	Coolant (Int./Ext.)	Stock VP15TF	Order Number	Dimensions (mm)			
					L3	L2	L1	D4
14.6	2	Ext.	□	MWE1460SA	56	56	111	14.6
	3	Ext.	●	MWE1460MA	91	91	153	14.6
	3	Int.	●	MWS1460MB	75	75	140	15.0
	5	Int.	●	MWS1460LB	120	120	185	15.0
	8	Int.	□	MWS1460X8DB	165	165	225	15.0
14.7	2	Ext.	□	MWE1470SA	56	56	111	14.7
	3	Ext.	●	MWE1470MA	91	91	153	14.7
	3	Int.	●	MWS1470MB	75	75	140	15.0
	5	Int.	●	MWS1470LB	120	120	185	15.0
	8	Int.	□	MWS1470X8DB	165	165	225	15.0
14.8	2	Ext.	□	MWE1480SA	56	56	111	14.8
	3	Ext.	●	MWE1480MA	91	91	153	14.8
	3	Int.	●	MWS1480MB	75	75	140	15.0
	5	Int.	●	MWS1480LB	120	120	185	15.0
	8	Int.	□	MWS1480X8DB	165	165	225	15.0
14.9	2	Ext.	□	MWE1490SA	56	56	111	14.9
	3	Ext.	●	MWE1490MA	91	91	153	14.9
	3	Int.	●	MWS1490MB	75	75	140	15.0
	5	Int.	●	MWS1490LB	120	120	185	15.0
	8	Int.	□	MWS1490X8DB	165	165	225	15.0
15.0	2	Ext.	●	MWE1500SA	56	56	111	15.0
	3	Ext.	●	MWE1500MA	91	91	153	15.0
	3	Int.	●	MWS1500MB	75	75	140	15.0
	5	Int.	●	MWS1500LB	120	120	185	15.0
	8	Int.	★	MWS1500X8DB	165	165	225	15.0
15.1	2	Ext.	□	MWE1510SA	58	58	115	15.1
	3	Ext.	●	MWE1510MA	94	94	157	15.1
	3	Int.	●	MWS1510MB	77.5	80	145	16.0
	5	Int.	●	MWS1510LB	124	128	193	16.0
	8	Ext.	□	MWS1510X8DB	171	181	241	16.0
15.2	2	Ext.	●	MWE1520SA	58	58	115	15.2
	3	Ext.	●	MWE1520MA	94	94	157	15.2
	3	Ext.	●	MWS1520MB	77.5	80	145	16.0
	5	Int.	●	MWS1520LB	124	128	193	16.0
	8	Int.	□	MWS1520X8DB	171	181	241	16.0
15.3	2	Ext.	□	MWE1530SA	58	58	115	15.3
	3	Ext.	●	MWE1530MA	94	94	157	15.3
	3	Int.	●	MWS1530MB	77.5	80	145	16.0
	5	Int.	●	MWS1530LB	124	128	193	16.0
	8	Ext.	□	MWS1530X8DB	171	181	241	16.0
15.4	2	Ext.	□	MWE1540SA	58	58	115	15.4
	3	Int.	●	MWE1540MA	94	94	157	15.4
	3	Ext.	●	MWS1540MB	77.5	80	145	16.0
	5	Ext.	●	MWS1540LB	124	128	193	16.0
	8	Int.	□	MWS1540X8DB	171	181	241	16.0
15.5	2	Int.	●	MWE1550SA	58	58	115	15.5
	3	Ext.	●	MWE1550MA	94	94	157	15.5
	3	Ext.	●	MWS1550MB	77.5	80	145	16.0
	5	Int.	●	MWS1550LB	124	128	193	16.0
	8	Int.	★	MWS1550X8DB	171	181	241	16.0

Drill Dia. D1 (mm)	Hole Depth (l/d)	Coolant (Int./Ext.)	Stock VP15TF	Order Number	Dimensions (mm)			
					L3	L2	L1	D4
15.6	2	Ext.	□	MWE1560SA	58	58	115	15.6
	3	Ext.	●	MWE1560MA	96	96	160	15.6
	3	Int.	●	MWS1560MB	80	80	145	16.0
	5	Int.	●	MWS1560LB	128	128	193	16.0
	8	Int.	□	MWS1560X8DB	176	181	241	16.0
15.7	2	Ext.	□	MWE1570SA	58	58	115	15.7
	3	Ext.	●	MWE1570MA	96	96	160	15.7
	3	Int.	●	MWS1570MB	80	80	145	16.0
	5	Int.	●	MWS1570LB	128	128	193	16.0
	8	Int.	□	MWS1570X8DB	176	181	241	16.0
15.8	2	Ext.	□	MWE1580SA	58	58	115	15.8
	3	Ext.	●	MWE1580MA	96	96	160	15.8
	3	Int.	●	MWS1580MB	80	80	145	16.0
	5	Int.	●	MWS1580LB	128	128	193	16.0
	8	Int.	□	MWS1580X8DB	176	181	241	16.0
15.9	2	Ext.	□	MWE1590SA	58	58	115	15.9
	3	Ext.	●	MWE1590MA	96	96	160	15.9
	3	Int.	●	MWS1590MB	80	80	145	16.0
	5	Int.	●	MWS1590LB	128	128	193	16.0
	8	Int.	□	MWS1590X8DB	176	181	241	16.0
16.0	2	Ext.	●	MWE1600SA	58	58	115	16.0
	3	Ext.	●	MWE1600MA	96	96	160	16.0
	3	Int.	●	MWS1600MB	80	80	145	16.0
	5	Int.	●	MWS1600LB	128	128	193	16.0
	8	Int.	★	MWS1600X8DB	176	181	241	16.0
16.1	2	Ext.	□	MWE1610SA	60	60	119	16.1
	3	Ext.	□	MWE1610MA	102	102	167	16.1
	3	Int.	□	MWS1610MB	82.5	85	150	17.0
	5	Int.	□	MWS1610LB	132	136	201	17.0
	16.2	2	Ext.	★	MWE1620SA	60	60	119
3		Ext.	□	MWE1620MA	102	102	167	16.2
3		Int.	□	MWS1620MB	82.5	85	150	17.0
5		Int.	□	MWS1620LB	132	136	201	17.0
16.3		2	Ext.	★	MWE1630SA	60	60	119
	3	Ext.	□	MWE1630MA	102	102	167	16.3
	3	Int.	★	MWS1630MB	82.5	85	150	17.0
	5	Int.	□	MWS1630LB	132	136	201	17.0
	16.4	2	Ext.	□	MWE1640SA	60	60	119
3		Ext.	□	MWE1640MA	102	102	167	16.4
3		Int.	□	MWS1640MB	82.5	85	150	17.0
5		Int.	□	MWS1640LB	132	136	201	17.0
16.5		2	Ext.	●	MWE1650SA	60	60	119
	3	Ext.	●	MWE1650MA	102	102	167	16.5
	3	Int.	●	MWS1650MB	82.5	85	150	17.0
	5	Int.	●	MWS1650LB	132	136	201	17.0
	16.6	2	Ext.	□	MWE1660SA	60	60	119
3		Ext.	□	MWE1660MA	102	102	167	16.6
3		Int.	□	MWS1660MB	85	85	150	17.0
5		Int.	□	MWS1660LB	136	136	201	17.0

MWE, MWS DRILLS



Ø 14.6 ~ 16.6

CUTTING CONDITIONS

D056

D045

DRILLING (SOLID CARBIDE)

MWE, MWS

- Suitable for high efficiency and high accuracy drilling over a wide variety of materials from general steel to difficult-to-cut materials.
- Suitable for low to high speed cutting. Possible to use in the range of HSS cutting.



P	M	K	S	N	H
✓	✓	✓	✓	✓	✓

MWE (External coolant)



VP15TF

D1(h8)	D1 ≤ 3.0	3.0 < D1 ≤ 6.0	6.0 < D1 ≤ 10.0	10.0 < D1 ≤ 18.0	18.0 < D1 ≤ 30.0
Tolerance	0 -0.014	0 -0.018	0 -0.022	0 -0.027	0 -0.033

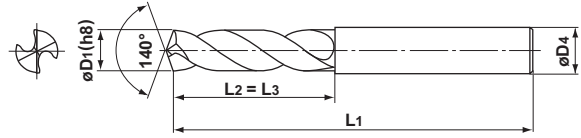

MWS (Internal coolant)



VP15TF

- The MWS-MB/LB/XB/X8DB type can be used for shrink fit holders.

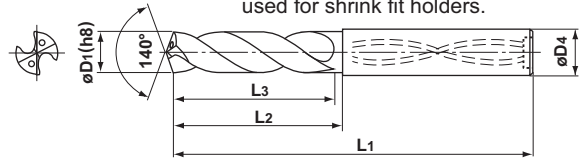

(Note) MWS type bigger than $\phi 5.0$ have a recess in the end face.

Drill Dia. D1 (mm)	Hole Depth (l/d)	Coolant (Int./Ext.)	Stock VP15TF	Order Number	Dimensions (mm)			
					L3	L2	L1	D4
16.7	2	Ext.	□	MWE1670SA	60	60	119	16.7
	3	Ext.	□	MWE1670MA	102	102	167	16.7
	3	Int.	□	MWS1670MB	85	85	150	17.0
	5	Int.	□	MWS1670LB	136	136	201	17.0
16.8	2	Ext.	□	MWE1680SA	60	60	119	16.8
	3	Ext.	□	MWE1680MA	102	102	167	16.8
	3	Int.	□	MWS1680MB	85	85	150	17.0
	5	Int.	□	MWS1680LB	136	136	201	17.0
16.9	2	Ext.	□	MWE1690SA	60	60	119	16.9
	3	Ext.	□	MWE1690MA	102	102	167	16.9
	3	Int.	□	MWS1690MB	85	85	150	17.0
	5	Int.	□	MWS1690LB	136	136	201	17.0
17.0	2	Ext.	●	MWE1700SA	60	60	119	17.0
	3	Ext.	●	MWE1700MA	102	102	167	17.0
	3	Int.	●	MWS1700MB	85	85	150	17.0
	5	Int.	●	MWS1700LB	136	136	201	17.0
17.1	2	Ext.	□	MWE1710SA	62	62	123	17.1
	3	Ext.	□	MWE1710MA	102	102	167	17.1
	3	Int.	□	MWS1710MB	87.5	90	155	18.0
	5	Int.	□	MWS1710LB	140	144	209	18.0
17.2	2	Ext.	□	MWE1720SA	62	62	123	17.2
	3	Ext.	□	MWE1720MA	102	102	167	17.2
	3	Int.	□	MWS1720MB	87.5	90	155	18.0
	5	Int.	□	MWS1720LB	140	144	209	18.0
17.3	2	Ext.	□	MWE1730SA	62	62	123	17.3
	3	Ext.	□	MWE1730MA	102	102	167	17.3
	3	Int.	□	MWS1730MB	87.5	90	155	18.0
	5	Int.	□	MWS1730LB	140	144	209	18.0
17.4	2	Ext.	□	MWE1740SA	62	62	123	17.4
	3	Ext.	□	MWE1740MA	102	102	167	17.4
	3	Int.	□	MWS1740MB	87.5	90	155	18.0
	5	Int.	□	MWS1740LB	140	144	209	18.0

Drill Dia. D1 (mm)	Hole Depth (l/d)	Coolant (Int./Ext.)	Stock VP15TF	Order Number	Dimensions (mm)			
					L3	L2	L1	D4
17.5	2	Ext.	●	MWE1750SA	62	62	123	17.5
	3	Ext.	●	MWE1750MA	102	102	167	17.5
	3	Int.	●	MWS1750MB	87.5	90	155	18.0
	5	Int.	●	MWS1750LB	140	144	209	18.0
17.6	2	Ext.	□	MWE1760SA	62	62	123	17.6
	3	Ext.	□	MWE1760MA	102	102	167	17.6
	3	Int.	□	MWS1760MB	90	90	155	18.0
	5	Int.	□	MWS1760LB	144	144	209	18.0
17.7	2	Ext.	□	MWE1770SA	62	62	123	17.7
	3	Ext.	□	MWE1770MA	102	102	167	17.7
	3	Int.	□	MWS1770MB	90	90	155	18.0
	5	Int.	□	MWS1770LB	144	144	209	18.0
17.8	2	Ext.	★	MWE1780SA	62	62	123	17.8
	3	Ext.	□	MWE1780MA	102	102	167	17.8
	3	Int.	□	MWS1780MB	90	90	155	18.0
	5	Int.	□	MWS1780LB	144	144	209	18.0
17.9	2	Ext.	□	MWE1790SA	62	62	123	17.9
	3	Ext.	□	MWE1790MA	102	102	167	17.9
	3	Int.	□	MWS1790MB	90	90	155	18.0
	5	Int.	□	MWS1790LB	144	144	209	18.0
18.0	2	Ext.	●	MWE1800SA	62	62	123	18.0
	3	Ext.	●	MWE1800MA	102	102	167	18.0
	3	Int.	●	MWS1800MB	90	90	155	18.0
	5	Int.	●	MWS1800LB	144	144	209	18.0
18.1	2	Ext.	□	MWE1810SA	64	64	127	18.1
	3	Ext.	□	MWE1810MA	114	114	179	18.1
	3	Int.	□	MWS1810MB	92.5	95	160	19.0
	5	Int.	□	MWS1810LB	148	152	217	19.0
18.2	2	Ext.	□	MWE1820SA	64	64	127	18.2
	3	Ext.	□	MWE1820MA	114	114	179	18.2
	3	Int.	□	MWS1820MB	92.5	95	160	19.0
	5	Int.	□	MWS1820LB	148	152	217	19.0

(Note) Please contact us for any geometry that is not in this catalogue (e.g. different diameters and lengths can be made to order).

DRILLING MWE, MWS DRILLS

DRILLING MWE, MWS DRILLS
 $\phi 16.7 \sim 18.2$

- : Stock Standard.
- ★ : Stock Standard in Japan.
- : Non stock, produced to order only.

Drill Dia. D1 (mm)	Hole Depth (l/d)	Coolant (Int./Ext.)	Stock VP15TF	Order Number	Dimensions (mm)			
					L3	L2	L1	D4
18.3	2	Ext.	□	MWE1830SA	64	64	64	18.3
	3	Ext.	□	MWE1830MA	114	114	114	18.3
	3	Int.	□	MWS1830MB	92.5	95	95	19.0
	5	Int.	□	MWS1830LB	148	152	152	19.0
18.4	2	Ext.	□	MWE1840SA	64	64	64	18.4
	3	Ext.	□	MWE1840MA	114	114	114	18.4
	3	Int.	□	MWS1840MB	92.5	95	95	19.0
	5	Int.	□	MWS1840LB	148	152	152	19.0
18.5	2	Ext.	●	MWE1850SA	64	64	64	18.5
	3	Ext.	●	MWE1850MA	114	114	114	18.5
	3	Int.	●	MWS1850MB	92.5	95	95	19.0
	5	Int.	●	MWS1850LB	148	152	152	19.0
18.6	2	Ext.	□	MWE1860SA	64	64	64	18.6
	3	Ext.	□	MWE1860MA	114	114	114	18.6
	3	Int.	□	MWS1860MB	95	95	95	19.0
	5	Int.	□	MWS1860LB	152	152	152	19.0
18.7	2	Ext.	□	MWE1870SA	64	64	127	18.7
	3	Ext.	□	MWE1870MA	114	114	179	18.7
	3	Int.	□	MWS1870MB	95	95	160	19.0
	5	Int.	□	MWS1870LB	152	152	217	19.0
18.8	2	Ext.	□	MWE1880SA	64	64	127	18.8
	3	Ext.	□	MWE1880MA	114	114	179	18.8
	3	Int.	□	MWS1880MB	95	95	160	19.0
	5	Int.	□	MWS1880LB	152	152	217	19.0
18.9	2	Ext.	□	MWE1890SA	64	64	127	18.9
	3	Ext.	□	MWE1890MA	114	114	179	18.9
	3	Int.	□	MWS1890MB	95	95	160	19.0
	5	Int.	□	MWS1890LB	152	152	217	19.0
19.0	2	Ext.	●	MWE1900SA	64	64	127	19.0
	3	Ext.	●	MWE1900MA	114	114	179	19.0
	3	Int.	●	MWS1900MB	95	95	160	19.0
	5	Int.	●	MWS1900LB	152	152	217	19.0
19.1	2	Ext.	□	MWE1910SA	66	66	131	19.1
	3	Ext.	□	MWE1910MA	114	114	179	19.1
	3	Int.	□	MWS1910MB	97.5	100	165	20.0
	5	Int.	□	MWS1910LB	156	160	225	20.0
19.2	2	Ext.	□	MWE1920SA	66	66	131	19.2
	3	Ext.	□	MWE1920MA	114	114	179	19.2
	3	Int.	□	MWS1920MB	97.5	100	165	20.0
	5	Int.	□	MWS1920LB	156	160	225	20.0
19.3	2	Ext.	□	MWE1930SA	66	66	131	19.3
	3	Ext.	□	MWE1930MA	114	114	179	19.3
	3	Int.	□	MWS1930MB	97.5	100	165	20.0
	5	Int.	□	MWS1930LB	156	160	225	20.0
19.4	2	Ext.	□	MWE1940SA	66	66	131	19.4
	3	Ext.	□	MWE1940MA	114	114	179	19.4
	3	Int.	□	MWS1940MB	97.5	100	165	20.0
	5	Int.	□	MWS1940LB	156	160	225	20.0

Drill Dia. D1 (mm)	Hole Depth (l/d)	Coolant (Int./Ext.)	Stock VP15TF	Order Number	Dimensions (mm)			
					L3	L2	L1	D4
19.5	2	Ext.	●	MWE1950SA	66	66	131	19.5
	3	Ext.	●	MWE1950MA	114	114	179	19.5
	3	Int.	●	MWS1950MB	97.5	100	165	20.0
	5	Int.	●	MWS1950LB	156	160	225	20.0
19.6	2	Ext.	□	MWE1960SA	66	66	131	19.6
	3	Ext.	□	MWE1960MA	114	114	179	19.6
	3	Int.	□	MWS1960MB	100	100	165	20.0
	5	Int.	□	MWS1960LB	160	160	225	20.0
19.7	2	Ext.	□	MWE1970SA	66	66	131	19.7
	3	Ext.	□	MWE1970MA	114	114	179	19.7
	3	Int.	□	MWS1970MB	100	100	165	20.0
	5	Int.	□	MWS1970LB	160	160	225	20.0
19.8	2	Ext.	□	MWE1980SA	66	66	131	19.8
	3	Ext.	□	MWE1980MA	114	114	179	19.8
	3	Int.	□	MWS1980MB	100	100	165	20.0
	5	Int.	□	MWS1980LB	160	160	225	20.0
19.9	2	Int.	□	MWE1990SA	66	66	131	19.9
	3	Ext.	□	MWE1990MA	114	114	179	19.9
	3	Ext.	□	MWS1990MB	100	100	165	20.0
	5	Int.	□	MWS1990LB	160	160	225	20.0
20.0	2	Int.	●	MWE2000SA	66	66	131	20.0
	3	Int.	●	MWE2000MA	114	114	179	20.0
	3	Ext.	●	MWS2000MB	100	100	165	20.0
	5	Ext.	●	MWS2000LB	160	160	225	20.0
20.5	3	Int.	★	MWS2050MB	103	105	176	21.0
	5	Int.	★	MWS2050LB	166	168	239	21.0
21.0	3	Int.	★	MWS2100MB	105	105	176	21.0
	5	Int.	★	MWS2100LB	168	168	239	21.0
21.5	3	Int.	★	MWS2150MB	108	110	182	22.0
	5	Int.	★	MWS2150LB	174	176	248	22.0
22.0	3	Int.	★	MWS2200MB	110	110	182	22.0
	5	Int.	★	MWS2200LB	176	176	248	22.0
22.5	3	Int.	★	MWS2250MB	113	115	188	23.0
	5	Int.	★	MWS2250LB	182	184	257	23.0
23.0	3	Int.	★	MWS2300MB	115	115	188	23.0
	5	Int.	★	MWS2300LB	184	184	257	23.0
23.5	5	Int.	★	MWS2350MB	118	120	194	24.0
	5	Int.	★	MWS2350LB	190	192	266	24.0
24.0	3	Int.	★	MWS2400MB	120	120	194	24.0
	5	Int.	★	MWS2400LB	192	192	266	24.0
24.5	3	Int.	★	MWS2450MB	123	125	200	25.0
	5	Int.	★	MWS2450LB	198	200	270	25.0
25.0	3	Int.	★	MWS2500MB	125	125	200	25.0
	5	Int.	★	MWS2500LB	200	200	270	25.0

MWE, MWS DRILLS



Ø 18.3 ~ 25.0

CUTTING CONDITIONS



D056

D047



MWS SUPER LONG

**2 Margin MWS Solid Carbide Super Long drill
for deep hole drilling up to 30xD.**



PRECISION
FOR SUCCESS

CHOOSE JAPAN'S NO. 1

mitsubishi
MITSUBISHI MATERIALS

www.mitsubishicarbide.com

P ✓	M ✓	K ✓	S ✓	N ✓	H
------------	------------	------------	------------	------------	----------

D1	D1 ≤ 3.0	3.0 < D1 ≤ 6.0	6.0 < D1 ≤ 10.0	10.0 < D1 ≤ 14.0
Tolerance	-0.017 -0.031	-0.025 -0.043	-0.033 -0.055	-0.041 -0.068

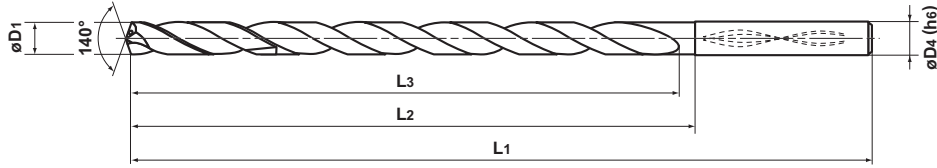

(Note 1) The MWS type long drill can be used for shrink fit holders.
 (Note 2) MWS type long drill bigger than ø5.0 have a recess in the end face.

Drill Dia. D1 (mm)	Hole Depth (l/d)	Coolant (Int./Ext.)	Stock VP15TF	Order Number	Dimensions (mm)			
					L3	L2	L1	D4
3.0	10	Int.	★	MWS0300X10DB	39	42	90	3
	15	Int.	★	0300X15DB	54	57	105	3
	20	Int.	★	0300X20DB	69	72	120	3
	25	Int.	★	0300X25DB	84	87	135	3
	30	Int.	★	0300X30DB	99	102	150	3
3.1	10	Int.	★	0310X10DB	46	49	97	4
	15	Int.	★	0310X15DB	63	66	114	4
	20	Int.	★	0310X20DB	81	84	132	4
	25	Int.	★	0310X25DB	98	101	149	4
	30	Int.	★	0310X30DB	116	119	167	4
3.2	10	Int.	★	0320X10DB	46	49	97	4
	15	Int.	★	0320X15DB	63	66	114	4
	20	Int.	★	0320X20DB	81	84	132	4
	25	Int.	★	0320X25DB	98	101	149	4
	30	Int.	★	0320X30DB	116	119	167	4
3.3	10	Int.	★	0330X10DB	46	49	97	4
	15	Int.	★	0330X15DB	63	66	114	4
	20	Int.	★	0330X20DB	81	84	132	4
	25	Int.	★	0330X25DB	98	101	149	4
	30	Int.	★	0330X30DB	116	119	167	4
3.4	10	Int.	★	0340X10DB	46	49	97	4
	15	Int.	★	0340X15DB	63	66	114	4
	20	Int.	★	0340X20DB	81	84	132	4
	25	Int.	★	0340X25DB	98	101	149	4
	30	Int.	★	0340X30DB	116	119	167	4
3.5	10	Int.	★	0350X10DB	46	49	97	4
	15	Int.	★	0350X15DB	63	66	114	4
	20	Int.	★	0350X20DB	81	84	132	4
	25	Int.	★	0350X25DB	98	101	149	4
	30	Int.	★	0350X30DB	116	119	167	4
3.6	10	Int.	★	0360X10DB	52	55	103	4
	15	Int.	★	0360X15DB	72	75	123	4
	20	Int.	★	0360X20DB	92	95	143	4
	25	Int.	★	0360X25DB	112	115	163	4
	30	Int.	★	0360X30DB	132	135	183	4

Drill Dia. D1 (mm)	Hole Depth (l/d)	Coolant (Int./Ext.)	Stock VP15TF	Order Number	Dimensions (mm)			
					L3	L2	L1	D4
3.7	10	Int.	★	MWS0370X10DB	52	55	103	4
	15	Int.	★	0370X15DB	72	75	123	4
	20	Int.	★	0370X20DB	92	95	143	4
	25	Int.	★	0370X25DB	112	115	163	4
	30	Int.	★	0370X30DB	132	135	183	4
3.8	10	Int.	★	0380X10DB	52	55	103	4
	15	Int.	★	0380X15DB	72	75	123	4
	20	Int.	★	0380X20DB	92	95	143	4
	25	Int.	★	0380X25DB	112	115	163	4
	30	Int.	★	0380X30DB	132	135	183	4
3.9	10	Int.	★	0390X10DB	52	55	103	4
	15	Int.	★	0390X15DB	72	75	123	4
	20	Int.	★	0390X20DB	92	95	143	4
	25	Int.	★	0390X25DB	112	115	163	4
	30	Int.	★	0390X30DB	132	135	183	4
4.0	10	Int.	★	0400X10DB	52	55	103	4
	15	Int.	★	0400X15DB	72	75	123	4
	20	Int.	★	0400X20DB	92	95	143	4
	25	Int.	★	0400X25DB	112	115	163	4
	30	Int.	★	0400X30DB	132	135	183	4
4.1	10	Int.	★	0410X10DB	59	62	112	5
	15	Int.	★	0410X15DB	81	84	134	5
	20	Int.	★	0410X20DB	104	107	157	5
	25	Int.	★	0410X25DB	126	129	179	5
	30	Int.	★	0410X30DB	149	152	202	5
4.2	10	Int.	★	0420X10DB	59	62	112	5
	15	Int.	★	0420X15DB	81	84	134	5
	20	Int.	★	0420X20DB	104	107	157	5
	25	Int.	★	0420X25DB	126	129	179	5
	30	Int.	★	0420X30DB	149	152	202	5
4.3	10	Int.	★	0430X10DB	59	62	112	5
	15	Int.	★	0430X15DB	81	84	134	5
	20	Int.	★	0430X20DB	104	107	157	5
	25	Int.	★	0430X25DB	126	129	179	5
	30	Int.	★	0430X30DB	149	152	202	5

DRILLING (SOLID CARBIDE)

MWS SUPER LONG

- For 10-30×D hole depth drilling.
- Can be used with minimum lubricant for steel and cast iron.



P ✓	M ✓	K ✓	S ✓	N ✓	H
------------	------------	------------	------------	------------	----------

D1	D1 ≤ 3.0	3.0 < D1 ≤ 6.0	6.0 < D1 ≤ 10.0	10.0 < D1 ≤ 14.0
Tolerance	-0.017 -0.031	-0.025 -0.043	-0.033 -0.055	-0.041 -0.068

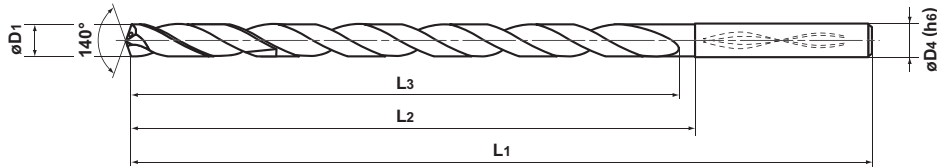

(Note 1) The MWS type long drill can be used for shrink fit holders.

(Note 2) MWS type long drill bigger than $\phi 5.0$ have a recess in the end face.

MWS SUPER LONG DRILLS

Drill Dia. D1 (mm)	Hole Depth (l/d)	Coolant (Int./Ext.)	Stock VP15TF	Order Number	Dimensions (mm)			
					L3	L2	L1	D4
4.4	10	Int.	★	MWS0440X10DB	59	62	112	5
	15	Int.	★	0440X15DB	81	84	134	5
	20	Int.	★	0440X20DB	104	107	157	5
	25	Int.	★	0440X25DB	126	129	179	5
	30	Int.	★	0440X30DB	149	152	202	5
4.5	10	Int.	★	0450X10DB	59	62	112	5
	15	Int.	★	0450X15DB	81	84	134	5
	20	Int.	★	0450X20DB	104	107	157	5
	25	Int.	★	0450X25DB	126	129	179	5
	30	Int.	★	0450X30DB	149	152	202	5
4.6	10	Int.	★	0460X10DB	65	68	118	5
	15	Int.	★	0460X15DB	90	93	143	5
	20	Int.	★	0460X20DB	115	118	168	5
	25	Int.	★	0460X25DB	140	143	193	5
	30	Int.	★	0460X30DB	165	168	218	5
4.7	10	Int.	★	0470X10DB	65	68	118	5
	15	Int.	★	0470X15DB	90	93	143	5
	20	Int.	★	0470X20DB	115	118	168	5
	25	Int.	★	0470X25DB	140	143	193	5
	30	Int.	★	0470X30DB	165	168	218	5
4.8	10	Int.	★	0480X10DB	65	68	118	5
	15	Int.	★	0480X15DB	90	93	143	5
	20	Int.	★	0480X20DB	115	118	168	5
	25	Int.	★	0480X25DB	140	143	193	5
	30	Int.	★	0480X30DB	165	168	218	5
4.9	10	Int.	★	0490X10DB	65	68	118	5
	15	Int.	★	0490X15DB	90	93	143	5
	20	Int.	★	0490X20DB	115	118	168	5
	25	Int.	★	0490X25DB	140	143	193	5
	30	Int.	★	0490X30DB	165	168	218	5
5.0	10	Int.	★	0500X10DB	65	68	118	5
	15	Int.	★	0500X15DB	90	93	143	5
	20	Int.	★	0500X20DB	115	118	168	5
	25	Int.	★	0500X25DB	140	143	193	5
	30	Int.	★	0500X30DB	165	168	218	5

Drill Dia. D1 (mm)	Hole Depth (l/d)	Coolant (Int./Ext.)	Stock VP15TF	Order Number	Dimensions (mm)			
					L3	L2	L1	D4
5.1	10	Int.	★	MWS0510X10DB	72	75	127	6
	15	Int.	★	0510X15DB	99	102	154	6
	20	Int.	★	0510X20DB	127	130	182	6
	25	Int.	★	0510X25DB	154	157	209	6
	30	Int.	★	0510X30DB	182	185	237	6
5.2	10	Int.	★	0520X10DB	72	75	127	6
	15	Int.	★	0520X15DB	99	102	154	6
	20	Int.	★	0520X20DB	127	130	182	6
	25	Int.	★	0520X25DB	154	157	209	6
	30	Int.	★	0520X30DB	182	185	237	6
5.3	10	Int.	★	0530X10DB	72	75	127	6
	15	Int.	★	0530X15DB	99	102	154	6
	20	Int.	★	0530X20DB	127	130	182	6
	25	Int.	★	0530X25DB	154	157	209	6
	30	Int.	★	0530X30DB	182	185	237	6
5.4	10	Int.	★	0540X10DB	72	75	127	6
	15	Int.	★	0540X15DB	99	102	154	6
	20	Int.	★	0540X20DB	127	130	182	6
	25	Int.	★	0540X25DB	154	157	209	6
	30	Int.	★	0540X30DB	182	185	237	6
5.5	10	Int.	★	0550X10DB	72	75	127	6
	15	Int.	★	0550X15DB	99	102	154	6
	20	Int.	★	0550X20DB	127	130	182	6
	25	Int.	★	0550X25DB	154	157	209	6
	30	Int.	★	0550X30DB	182	185	237	6
5.6	10	Int.	★	0560X10DB	78	81	133	6
	15	Int.	★	0560X15DB	108	111	163	6
	20	Int.	★	0560X20DB	138	141	193	6
	25	Int.	★	0560X25DB	168	171	223	6
	30	Int.	★	0560X30DB	198	201	253	6
5.7	10	Int.	★	0570X10DB	78	81	133	6
	15	Int.	★	0570X15DB	108	111	163	6
	20	Int.	★	0570X20DB	138	141	193	6
	25	Int.	★	0570X25DB	168	171	223	6
	30	Int.	★	0570X30DB	198	201	253	6

(Note) Please contact us for any geometry that is not in this catalogue (e.g. different diameters and lengths can be made to order).

- : Stock Standard
- ★ : Stock Standard in Japan.
- : Non stock, produced to order only

Drill Dia. D1 (mm)	Hole Depth (l/d)	Coolant (Int./Ext.)	Stock VP15TF	Order Number	Dimensions (mm)			
					L3	L2	L1	D4
5.8	10	Int.	s	MWS0580X10DB	78	81	133	6
	15	Int.	s	0580X15DB	108	111	163	6
	20	Int.	s	0580X20DB	138	141	193	6
	25	Int.	s	0580X25DB	168	171	223	6
	30	Int.	s	0580X30DB	198	201	253	6
5.9	10	Int.	★	0590X10DB	78	81	133	6
	15	Int.	★	0590X15DB	108	111	163	6
	20	Int.	★	0590X20DB	138	141	193	6
	25	Int.	★	0590X25DB	168	171	223	6
	30	Int.	★	0590X30DB	198	201	253	6
6.0	10	Int.	★	0600X10DB	78	81	133	6
	15	Int.	★	0600X15DB	108	111	163	6
	20	Int.	★	0600X20DB	138	141	193	6
	25	Int.	★	0600X25DB	168	171	223	6
	30	Int.	★	0600X30DB	198	201	253	6
6.1	10	Int.	★	0610X10DB	85	88	141	7
	15	Int.	★	0610X15DB	117	120	173	7
	20	Int.	★	0610X20DB	150	153	206	7
	25	Int.	★	0610X25DB	182	185	238	7
	30	Int.	★	0610X30DB	215	218	271	7
6.2	10	Int.	★	0620X10DB	85	88	141	7
	15	Int.	★	0620X15DB	117	120	173	7
	20	Int.	★	0620X20DB	150	153	206	7
	25	Int.	★	0620X25DB	182	185	238	7
	30	Int.	★	0620X30DB	215	218	271	7
6.3	10	Int.	★	0630X10DB	85	88	141	7
	15	Int.	★	0630X15DB	117	120	173	7
	20	Int.	★	0630X20DB	150	153	206	7
	25	Int.	★	0630X25DB	182	185	238	7
	30	Int.	★	0630X30DB	215	218	271	7
6.4	10	Int.	★	0640X10DB	85	88	141	7
	15	Int.	★	0640X15DB	117	120	173	7
	20	Int.	★	0640X20DB	150	153	206	7
	25	Int.	★	0640X25DB	182	185	238	7
	30	Int.	★	0640X30DB	215	218	271	7
6.5	10	Int.	★	0650X10DB	85	88	141	7
	15	Int.	★	0650X15DB	117	120	173	7
	20	Int.	★	0650X20DB	150	153	206	7
	25	Int.	★	0650X25DB	182	185	238	7
	30	Int.	★	0650X30DB	215	218	271	7
6.6	10	Int.	★	0660X10DB	91	94	147	7
	15	Int.	★	0660X15DB	126	129	182	7
	20	Int.	★	0660X20DB	161	164	217	7
	25	Int.	★	0660X25DB	196	199	252	7
	30	Int.	★	0660X30DB	231	234	287	7
6.7	10	Int.	★	0670X10DB	91	94	147	7
	15	Int.	★	0670X15DB	126	129	182	7
	20	Int.	★	0670X20DB	161	164	217	7
	25	Int.	★	0670X25DB	196	199	252	7
	30	Int.	★	0670X30DB	231	234	287	7

Drill Dia. D1 (mm)	Hole Depth (l/d)	Coolant (Int./Ext.)	Stock VP15TF	Order Number	Dimensions (mm)			
					L3	L2	L1	D4
6.8	10	Int.	★	MWS0680X10DB	91	94	147	7
	15	Int.	★	0680X15DB	126	129	182	7
	20	Int.	★	0680X20DB	161	164	217	7
	25	Int.	★	0680X25DB	196	199	252	7
	30	Int.	★	0680X30DB	231	234	287	7
6.9	10	Int.	★	0690X10DB	91	94	147	7
	15	Int.	★	0690X15DB	126	129	182	7
	20	Int.	★	0690X20DB	161	164	217	7
	25	Int.	★	0690X25DB	196	199	252	7
	30	Int.	★	0690X30DB	231	234	287	7
7.0	10	Int.	★	0700X10DB	91	94	147	7
	15	Int.	★	0700X15DB	126	129	182	7
	20	Int.	★	0700X20DB	161	164	217	7
	25	Int.	★	0700X25DB	196	199	252	7
	30	Int.	★	0700X30DB	231	234	287	7
7.1	10	Int.	★	0710X10DB	98	101	155	8
	15	Int.	★	0710X15DB	135	138	192	8
	20	Int.	★	0710X20DB	173	176	230	8
	25	Int.	★	0710X25DB	210	213	267	8
	30	Int.	★	0710X30DB	248	251	305	8
7.2	10	Int.	★	0720X10DB	98	101	155	8
	15	Int.	★	0720X15DB	135	138	192	8
	20	Int.	★	0720X20DB	173	176	230	8
	25	Int.	★	0720X25DB	210	213	267	8
	30	Int.	★	0720X30DB	248	251	305	8
7.3	10	Int.	★	0730X10DB	98	101	155	8
	15	Int.	★	0730X15DB	135	138	192	8
	20	Int.	★	0730X20DB	173	176	230	8
	25	Int.	★	0730X25DB	210	213	267	8
	30	Int.	★	0730X30DB	248	251	305	8
7.4	10	Int.	★	0740X10DB	98	101	155	8
	15	Int.	★	0740X15DB	135	138	192	8
	20	Int.	★	0740X20DB	173	176	230	8
	25	Int.	★	0740X25DB	210	213	267	8
	30	Int.	★	0740X30DB	248	251	305	8
7.5	10	Int.	★	0750X10DB	98	101	155	8
	15	Int.	★	0750X15DB	135	138	192	8
	20	Int.	★	0750X20DB	173	176	230	8
	25	Int.	★	0750X25DB	210	213	267	8
	30	Int.	★	0750X30DB	248	251	305	8
7.6	10	Int.	★	0760X10DB	104	107	161	8
	15	Int.	★	0760X15DB	144	147	201	8
	20	Int.	★	0760X20DB	184	187	241	8
	25	Int.	★	0760X25DB	224	227	281	8
	30	Int.	★	0760X30DB	264	267	321	8
7.7	10	Int.	★	0770X10DB	104	107	161	8
	15	Int.	★	0770X15DB	144	147	201	8
	20	Int.	★	0770X20DB	184	187	241	8
	25	Int.	★	0770X25DB	224	227	281	8
	30	Int.	★	0770X30DB	264	267	321	8

MWS SUPER LONG DRILLS



Ø 5.8 ~ 7.7

DRILLING (SOLID CARBIDE)

MWS SUPER LONG

- For 10-30×D hole depth drilling.
- Can be used with minimum lubricant for steel and cast iron.



P ✓	M ✓	K ✓	S ✓	N ✓	H
------------	------------	------------	------------	------------	----------

D1	D1 ≤ 3.0	3.0 < D1 ≤ 6.0	6.0 < D1 ≤ 10.0	10.0 < D1 ≤ 14.0
Tolerance	-0.017 -0.031	-0.025 -0.043	-0.033 -0.055	-0.041 -0.068

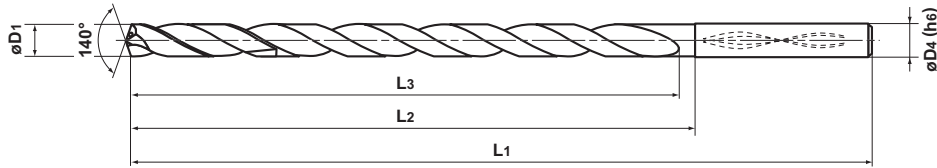

(Note 1) The MWS type long drill can be used for shrink fit holders.

(Note 2) MWS type long drill bigger than ø5.0 have a recess in the end face.

MWS SUPER LONG DRILLS

Drill Dia. D1 (mm)	Hole Depth (l/d)	Coolant (Int./Ext.)	Stock VP15TF	Order Number	Dimensions (mm)			
					L3	L2	L1	D4
7.8	10	Int.	★	MWS0780X10DB	104	107	161	8
	15	Int.	★	0780X15DB	144	147	201	8
	20	Int.	★	0780X20DB	184	187	241	8
	25	Int.	★	0780X25DB	224	227	281	8
	30	Int.	★	0780X30DB	264	267	321	8
7.9	10	Int.	★	0790X10DB	104	107	161	8
	15	Int.	★	0790X15DB	144	147	201	8
	20	Int.	★	0790X20DB	184	187	241	8
	25	Int.	★	0790X25DB	224	227	281	8
	30	Int.	★	0790X30DB	264	267	321	8
8.0	10	Int.	★	0800X10DB	104	107	161	8
	15	Int.	★	0800X15DB	144	147	201	8
	20	Int.	★	0800X20DB	184	187	241	8
	25	Int.	★	0800X25DB	224	227	281	8
	30	Int.	★	0800X30DB	264	267	321	8
8.1	10	Int.	★	0810X10DB	111	114	169	9
	15	Int.	★	0810X15DB	153	156	211	9
	20	Int.	★	0810X20DB	196	199	254	9
	25	Int.	★	0810X25DB	238	241	296	9
	30	Int.	★	0810X30DB	281	284	339	9
8.2	10	Int.	★	0820X10DB	111	114	169	9
	15	Int.	★	0820X15DB	153	156	211	9
	20	Int.	★	0820X20DB	196	199	254	9
	25	Int.	★	0820X25DB	238	241	296	9
	30	Int.	★	0820X30DB	281	284	339	9
8.3	10	Int.	★	0830X10DB	111	114	169	9
	15	Int.	★	0830X15DB	153	156	211	9
	20	Int.	★	0830X20DB	196	199	254	9
	25	Int.	★	0830X25DB	238	241	296	9
	30	Int.	★	0830X30DB	281	284	339	9
8.4	10	Int.	★	0840X10DB	111	114	169	9
	15	Int.	★	0840X15DB	153	156	211	9
	20	Int.	★	0840X20DB	196	199	254	9
	25	Int.	★	0840X25DB	238	241	296	9
	30	Int.	★	0840X30DB	281	284	339	9

Drill Dia. D1 (mm)	Hole Depth (l/d)	Coolant (Int./Ext.)	Stock VP15TF	Order Number	Dimensions (mm)			
					L3	L2	L1	D4
8.5	10	Int.	★	MWS0850X10DB	111	114	169	9
	15	Int.	★	0850X15DB	153	156	211	9
	20	Int.	★	0850X20DB	196	199	254	9
	25	Int.	★	0850X25DB	238	241	296	9
	30	Int.	★	0850X30DB	281	284	339	9
8.6	10	Int.	★	0860X10DB	117	120	175	9
	15	Int.	★	0860X15DB	162	165	220	9
	20	Int.	★	0860X20DB	207	210	265	9
	25	Int.	★	0860X25DB	252	255	310	9
	30	Int.	★	0860X30DB	297	300	355	9
8.7	10	Int.	★	0870X10DB	117	120	175	9
	15	Int.	★	0870X15DB	162	165	220	9
	20	Int.	★	0870X20DB	207	210	265	9
	25	Int.	★	0870X25DB	252	255	310	9
	30	Int.	★	0870X30DB	297	300	355	9
8.8	10	Int.	★	0880X10DB	117	120	175	9
	15	Int.	★	0880X15DB	162	165	220	9
	20	Int.	★	0880X20DB	207	210	265	9
	25	Int.	★	0880X25DB	252	255	310	9
	30	Int.	★	0880X30DB	297	300	355	9
8.9	10	Int.	★	0890X10DB	117	120	175	9
	15	Int.	★	0890X15DB	162	165	220	9
	20	Int.	★	0890X20DB	207	210	265	9
	25	Int.	★	0890X25DB	252	255	310	9
	30	Int.	★	0890X30DB	297	300	355	9
9.0	10	Int.	★	0900X10DB	117	120	175	9
	15	Int.	★	0900X15DB	162	165	220	9
	20	Int.	★	0900X20DB	207	210	265	9
	25	Int.	★	0900X25DB	252	255	310	9
	30	Int.	★	0900X30DB	297	300	355	9
9.1	10	Int.	★	0910X10DB	124	127	182	10
	15	Int.	★	0910X15DB	171	174	229	10
	20	Int.	★	0910X20DB	219	222	277	10
	25	Int.	★	0910X25DB	266	269	324	10
	30	Int.	★	0910X30DB	314	317	372	10

(Note) Please contact us for any geometry that is not in this catalogue (e.g. different diameters and lengths can be made to order).



ø 7.8 ~ 9.1

- : Stock Standard
- ★ : Stock Standard in Japan.
- : Non stock, produced to order only

Drill Dia. D1 (mm)	Hole Depth (l/d)	Coolant (Int./Ext.)	Stock VP15TF	Order Number	Dimensions (mm)			
					L3	L2	L1	D4
9.2	10	Int.	★	MWS0920X10DB	124	127	182	10
	15	Int.	★	0920X15DB	171	174	229	10
	20	Int.	★	0920X20DB	219	222	277	10
	25	Int.	★	0920X25DB	266	269	324	10
	30	Int.	★	0920X30DB	314	317	372	10
9.3	10	Int.	★	0930X10DB	124	127	182	10
	15	Int.	★	0930X15DB	171	174	229	10
	20	Int.	★	0930X20DB	219	222	277	10
	25	Int.	★	0930X25DB	266	269	324	10
	30	Int.	★	0930X30DB	314	317	372	10
9.4	10	Int.	★	0940X10DB	124	127	182	10
	15	Int.	★	0940X15DB	171	174	229	10
	20	Int.	★	0940X20DB	219	222	277	10
	25	Int.	★	0940X25DB	266	269	324	10
	30	Int.	★	0940X30DB	314	317	372	10
9.5	10	Int.	★	0950X10DB	124	127	182	10
	15	Int.	★	0950X15DB	171	174	229	10
	20	Int.	★	0950X20DB	219	222	277	10
	25	Int.	★	0950X25DB	266	269	324	10
	30	Int.	★	0950X30DB	314	317	372	10
9.6	10	Int.	★	0960X10DB	130	133	188	10
	15	Int.	★	0960X15DB	180	183	238	10
	20	Int.	★	0960X20DB	230	233	288	10
	25	Int.	★	0960X25DB	280	283	338	10
	30	Int.	★	0960X30DB	330	333	388	10
9.7	10	Int.	★	0970X10DB	130	133	188	10
	15	Int.	★	0970X15DB	180	183	238	10
	20	Int.	★	0970X20DB	230	233	288	10
	25	Int.	★	0970X25DB	280	283	338	10
	30	Int.	★	0970X30DB	330	333	388	10
9.8	10	Int.	★	0980X10DB	130	133	188	10
	15	Int.	★	0980X15DB	180	183	238	10
	20	Int.	★	0980X20DB	230	233	288	10
	25	Int.	★	0980X25DB	280	283	338	10
	30	Int.	★	0980X30DB	330	333	388	10
9.9	10	Int.	★	0990X10DB	130	133	188	10
	15	Int.	★	0990X15DB	180	183	238	10
	20	Int.	★	0990X20DB	230	233	288	10
	25	Int.	★	0990X25DB	280	283	338	10
	30	Int.	★	0990X30DB	330	333	388	10
10.0	10	Int.	★	1000X10DB	130	133	188	10
	15	Int.	★	1000X15DB	180	183	238	10
	20	Int.	★	1000X20DB	230	233	288	10
	25	Int.	★	1000X25DB	280	283	338	10
	30	Int.	★	1000X30DB	330	333	388	10
10.1	10	Int.	★	1010X10DB	137	140	201	11
	15	Int.	★	1010X15DB	189	192	253	11
	20	Int.	★	1010X20DB	242	245	306	11
	25	Int.	★	1010X25DB	294	297	358	11

Drill Dia. D1 (mm)	Hole Depth (l/d)	Coolant (Int./Ext.)	Stock VP15TF	Order Number	Dimensions (mm)			
					L3	L2	L1	D4
10.2	10	Int.	★	MWS1020X10DB	137	140	201	11
	15	Int.	★	1020X15DB	189	192	253	11
	20	Int.	★	1020X20DB	242	245	306	11
	25	Int.	★	1020X25DB	294	297	358	11
	10.3	10	Int.	★	1030X10DB	137	140	201
15		Int.	★	1030X15DB	189	192	253	11
20		Int.	★	1030X20DB	242	245	306	11
25		Int.	★	1030X25DB	294	297	358	11
10.4		10	Int.	★	1040X10DB	137	140	201
	15	Int.	★	1040X15DB	189	192	253	11
	20	Int.	★	1040X20DB	242	245	306	11
	25	Int.	★	1040X25DB	294	297	358	11
	10.5	10	Int.	★	1050X10DB	137	140	201
15		Int.	★	1050X15DB	189	192	253	11
20		Int.	★	1050X20DB	242	245	306	11
25		Int.	★	1050X25DB	294	297	358	11
10.6		10	Int.	★	1060X10DB	143	146	207
	15	Int.	★	1060X15DB	198	201	262	11
	20	Int.	★	1060X20DB	253	256	317	11
	25	Int.	★	1060X25DB	308	311	372	11
	10.7	10	Int.	★	1070X10DB	143	146	207
15		Int.	★	1070X15DB	198	201	262	11
20		Int.	★	1070X20DB	253	256	317	11
25		Int.	★	1070X25DB	308	311	372	11
10.8		10	Int.	★	1080X10DB	143	146	207
	15	Int.	★	1080X15DB	198	201	262	11
	20	Int.	★	1080X20DB	253	256	317	11
	25	Int.	★	1080X25DB	308	311	372	11
	10.9	10	Int.	★	1090X10DB	143	146	207
15		Int.	★	1090X15DB	198	201	262	11
20		Int.	★	1090X20DB	253	256	317	11
25		Int.	★	1090X25DB	308	311	372	11
11.0		10	Int.	★	1100X10DB	143	146	207
	15	Int.	★	1100X15DB	198	201	262	11
	20	Int.	★	1100X20DB	253	256	317	11
	25	Int.	★	1100X25DB	308	311	372	11
	11.1	10	Int.	★	1110X10DB	150	153	215
15		Int.	★	1110X15DB	207	210	272	12
20		Int.	★	1110X20DB	265	268	330	12
25		Int.	★	1110X25DB	322	325	387	12
11.2		10	Int.	★	1120X10DB	150	153	215
	15	Int.	★	1120X15DB	207	210	272	12
	20	Int.	★	1120X20DB	265	268	330	12
	25	Int.	★	1120X25DB	322	325	387	12
	11.3	10	Int.	★	1130X10DB	150	153	215
15		Int.	★	1130X15DB	207	210	272	12
20		Int.	★	1130X20DB	265	268	330	12
25		Int.	★	1130X25DB	322	325	387	12

MWS SUPER LONG DRILLS



Ø 9.2 ~ 11.3

CUTTING CONDITIONS

D057

D053

DRILLING (SOLID CARBIDE)

MWS SUPER LONG

- For 10-30×D hole depth drilling.
- Can be used with minimum lubricant for steel and cast iron.



P ✓	M ✓	K ✓	S ✓	N ✓	H
------------	------------	------------	------------	------------	----------

D1	D1 ≤ 3.0	3.0 < D1 ≤ 6.0	6.0 < D1 ≤ 10.0	10.0 < D1 ≤ 14.0
Tolerance	-0.017 -0.031	-0.025 -0.043	-0.033 -0.055	-0.041 -0.068

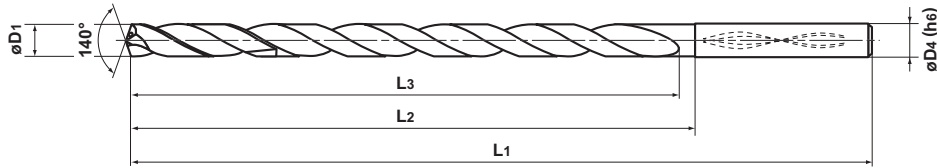

(Note 1) The MWS type long drill can be used for shrink fit holders.
 (Note 2) MWS type long drill bigger than $\phi 5.0$ have a recess in the end face.

DRILLING MWS SUPER LONG DRILLS

Drill Dia. D1 (mm)	Hole Depth (l/d)	Coolant (Int./Ext.)	Stock VP15TF	Order Number	Dimensions (mm)			
					L3	L2	L1	D4
11.4	10	Int.	★	MWS1140X10DB	150	153	215	12
	15	Int.	★	1140X15DB	207	210	272	12
	20	Int.	★	1140X20DB	265	268	330	12
	25	Int.	★	1140X25DB	322	325	387	12
11.5	10	Int.	★	1150X10DB	150	153	215	12
	15	Int.	★	1150X15DB	207	210	272	12
	20	Int.	★	1150X20DB	265	268	330	12
	25	Int.	★	1150X25DB	322	325	387	12
11.6	10	Int.	★	1160X10DB	156	159	221	12
	15	Int.	★	1160X15DB	216	219	281	12
	20	Int.	★	1160X20DB	276	279	341	12
	25	Int.	★	1160X25DB	336	339	401	12
11.7	10	Int.	★	1170X10DB	156	159	221	12
	15	Int.	★	1170X15DB	216	219	281	12
	20	Int.	★	1170X20DB	276	279	341	12
	25	Int.	★	1170X25DB	336	339	401	12
11.8	10	Int.	★	1180X10DB	156	159	221	12
	15	Int.	★	1180X15DB	216	219	281	12
	20	Int.	★	1180X20DB	276	279	341	12
	25	Int.	★	1180X25DB	336	339	401	12
11.9	10	Int.	★	1190X10DB	156	159	221	12
	15	Int.	★	1190X15DB	216	219	281	12
	20	Int.	★	1190X20DB	276	279	341	12
	25	Int.	★	1190X25DB	336	339	401	12
12.0	10	Int.	★	1200X10DB	156	159	221	12
	15	Int.	★	1200X15DB	216	219	281	12
	20	Int.	★	1200X20DB	276	279	341	12
	25	Int.	★	1200X25DB	336	339	401	12
12.1	10	Int.	★	1210X10DB	163	166	229	13
	15	Int.	★	1210X15DB	225	228	291	13
	20	Int.	★	1210X20DB	288	291	354	13
12.2	10	Int.	★	1220X10DB	163	166	229	13
	15	Int.	★	1220X15DB	225	228	291	13
	20	Int.	★	1220X20DB	288	291	354	13

Drill Dia. D1 (mm)	Hole Depth (l/d)	Coolant (Int./Ext.)	Stock VP15TF	Order Number	Dimensions (mm)			
					L3	L2	L1	D4
12.3	10	Int.	★	MWS1230X10DB	163	166	229	13
	15	Int.	★	1230X15DB	225	228	291	13
	20	Int.	★	1230X20DB	288	291	354	13
12.4	10	Int.	★	1240X10DB	163	166	229	13
	15	Int.	★	1240X15DB	225	228	291	13
	20	Int.	★	1240X20DB	288	291	354	13
12.5	10	Int.	★	1250X10DB	163	166	229	13
	15	Int.	★	1250X15DB	225	228	291	13
	20	Int.	★	1250X20DB	288	291	354	13
12.6	10	Int.	★	1260X10DB	169	172	235	13
	15	Int.	★	1260X15DB	234	237	300	13
	20	Int.	★	1260X20DB	299	302	365	13
12.7	10	Int.	★	1270X10DB	169	172	235	13
	15	Int.	★	1270X15DB	234	237	300	13
	20	Int.	★	1270X20DB	299	302	365	13
12.8	10	Int.	★	1280X10DB	169	172	235	13
	15	Int.	★	1280X15DB	234	237	300	13
	20	Int.	★	1280X20DB	299	302	365	13
12.9	10	Int.	★	1290X10DB	169	172	235	13
	15	Int.	★	1290X15DB	234	237	300	13
	20	Int.	★	1290X20DB	299	302	365	13
13.0	10	Int.	★	1300X10DB	169	172	235	13
	15	Int.	★	1300X15DB	234	237	300	13
	20	Int.	★	1300X20DB	299	302	365	13
13.1	10	Int.	★	1310X10DB	176	179	243	14
	15	Int.	★	1310X15DB	243	246	310	14
	20	Int.	★	1310X20DB	311	314	378	14
13.2	10	Int.	★	1320X10DB	176	179	243	14
	15	Int.	★	1320X15DB	243	246	310	14
	20	Int.	★	1320X20DB	311	314	378	14
13.3	10	Int.	★	1330X10DB	176	179	243	14
	15	Int.	★	1330X15DB	243	246	310	14
	20	Int.	★	1330X20DB	311	314	378	14
13.4	10	Int.	★	1340X10DB	176	179	243	14
	15	Int.	★	1340X15DB	243	246	310	14
	20	Int.	★	1340X20DB	311	314	378	14

Ø 11.4 ~ 13.4

- : Stock Standard
- ★ : Stock Standard in Japan.
- : Non stock, produced to order only

Drill Dia. D1 (mm)	Hole Depth (l/d)	Coolant (Int./Ext.)	Stock VP15TF	Order Number	Dimensions (mm)			
					L3	L2	L1	D4
13.5	10	Int.	★	MWS1350X10DB	176	179	243	14
	15	Int.	★	1350X15DB	243	246	310	14
	20	Int.	★	1350X20DB	311	314	378	14
13.6	10	Int.	★	1360X10DB	182	185	249	14
	15	Int.	★	1360X15DB	252	255	319	14
	20	Int.	★	1360X20DB	322	325	389	14
13.7	10	Int.	★	1370X10DB	182	185	249	14
	15	Int.	★	1370X15DB	252	255	319	14
	20	Int.	★	1370X20DB	322	325	389	14

Drill Dia. D1 (mm)	Hole Depth (l/d)	Coolant (Int./Ext.)	Stock VP15TF	Order Number	Dimensions (mm)			
					L3	L2	L1	D4
13.8	10	Int.	★	MWS1380X10DB	182	185	249	14
	15	Int.	★	1380X15DB	252	255	319	14
	20	Int.	★	1380X20DB	322	325	389	14
13.9	10	Int.	★	1390X10DB	182	185	249	14
	15	Int.	★	1390X15DB	252	255	319	14
	20	Int.	★	1390X20DB	322	325	389	14
14.0	10	Int.	★	1400X10DB	182	185	249	14
	15	Int.	★	1400X15DB	252	255	319	14
	20	Int.	★	1400X20DB	322	325	389	14

(Note) Please contact us for any geometry that is not in this catalogue (e.g. different diameters and lengths can be made to order).



RECOMMENDED CUTTING CONDITIONS

MINI MWS SB/LB/XB Type Drill

(1xD / 5xD / 12xD)

Work Material	Drill Diameter Conditions Hardness	φ0.50-φ0.70		φ0.71-φ0.85		φ0.86-φ0.99		φ1.0-φ2.95	
		Cutting Speed (m/min)	Feed (mm/rev)	Cutting Speed (m/min)	Feed (mm/rev)	Cutting Speed (m/min)	Feed (mm/rev)	Cutting Speed (m/min)	Feed (mm/rev)
P Mild Steel	≤180HB	50 (40-60)	0.010 (0.005-0.015)	50 (40-60)	0.02 (0.01-0.03)	50 (40-60)	0.03 (0.02-0.05)	50 (40-60)	0.08 (0.04-0.12)
	Carbon Steel Alloy Steel	180-280HB	50 (40-60)	0.010 (0.005-0.015)	50 (40-60)	0.02 (0.01-0.03)	50 (40-60)	0.03 (0.02-0.05)	50 (40-60)
		280-350HB	50 (40-60)	0.010 (0.005-0.015)	50 (40-60)	0.02 (0.01-0.03)	50 (40-60)	0.03 (0.02-0.05)	50 (40-60)
M Stainless Steel	≤200HB	30 (20-40)	0.008 (0.005-0.01)	30 (20-40)	0.015 (0.008-0.02)	30 (20-40)	0.02 (0.01-0.03)	30 (20-40)	0.05 (0.02-0.10)
K Cast Iron	Tensile Strength ≤350MPa	50 (40-60)	0.015 (0.008-0.02)	50 (40-60)	0.02 (0.01-0.03)	50 (40-60)	0.04 (0.02-0.06)	50 (40-60)	0.08 (0.04-0.12)
	Ductile Cast Iron Tensile Strength ≤450MPa	30 (20-40)	0.010 (0.005-0.015)	30 (20-40)	0.02 (0.01-0.03)	30 (20-40)	0.03 (0.02-0.05)	30 (20-40)	0.06 (0.02-0.10)
N Aluminium Alloy	-	60 (50-80)	0.03 (0.02-0.05)	60 (50-80)	0.04 (0.03-0.06)	60 (50-80)	0.06 (0.04-0.08)	60 (50-80)	0.10 (0.05-0.15)
S Heat Resistant Alloy	-	10 (5-15)	0.006 (0.004-0.008)	10 (5-15)	0.01 (0.005-0.02)	10 (5-15)	0.01 (0.005-0.02)	10 (5-15)	0.03 (0.01-0.05)

MINI MWS DB Super Long Drill

(20xD / 25xD / 30xD)

Work Material	Drill Diameter Conditions Hardness	φ1.0-φ2.0		φ2.05-φ2.95	
		Cutting Speed (m/min)	Feed (mm/rev)	Cutting Speed (m/min)	Feed (mm/rev)
P Mild Steel	≤180HB	50 (40-60)	0.08 (0.04-0.10)	60 (50-70)	0.10 (0.08-0.12)
	Carbon Steel Alloy Steel	180-280HB	40 (30-50)	0.07 (0.04-0.08)	50 (40-60)
		280-350HB	30 (20-40)	0.04 (0.03-0.06)	50 (40-60)
M Stainless Steel	≤200HB	30 (20-40)	0.03 (0.01-0.05)	30 (20-40)	0.06 (0.04-0.08)
K Cast Iron	Tensile Strength ≤350MPa	40 (30-50)	0.07 (0.04-0.08)	50 (40-60)	0.09 (0.06-0.12)
	Ductile Cast Iron Tensile Strength ≤450MPa	30 (20-40)	0.04 (0.03-0.06)	50 (40-60)	0.07 (0.05-0.10)
S Heat Resistant Alloy	-	10 (5-15)	0.02 (0.01-0.03)	15 (10-20)	0.03 (0.01-0.05)

(Note 1) For drill diameter up to φ2, peck feed drilling is recommended according to cutting modes and conditions.

(Note 2) Peck guide: 1 x D (drill diameter).



MWE SA/MA Type Drill

(2xD / 3xD)

Work Material	Drill Diameter Conditions Hardness	φ3.0-φ6.0		φ6.0-φ10.0		φ10.0-φ14.0		φ14.0-φ20.0	
		Cutting Speed (m/min)	Feed (mm/rev)	Cutting Speed (m/min)	Feed (mm/rev)	Cutting Speed (m/min)	Feed (mm/rev)	Cutting Speed (m/min)	Feed (mm/rev)
P Mild Steel	≤180HB	85 (35-100)	0.20 (0.15-0.30)	85 (45-120)	0.25 (0.15-0.35)	90 (55-120)	0.30 (0.20-0.35)	100 (60-130)	0.35 (0.20-0.40)
	180-280HB	80 (40-95)	0.20 (0.15-0.30)	90 (50-120)	0.25 (0.15-0.35)	90 (60-130)	0.30 (0.15-0.35)	90 (60-130)	0.35 (0.20-0.40)
Carbon Steel Alloy Steel	280-350HB	75 (35-80)	0.15 (0.15-0.20)	80 (45-115)	0.20 (0.15-0.25)	85 (55-115)	0.25 (0.15-0.30)	85 (55-115)	0.30 (0.20-0.35)
	≤200HB	20 (15-30)	0.10 (0.05-0.15)	25 (15-30)	0.12 (0.05-0.15)	25 (15-30)	0.15 (0.10-0.20)	25 (15-30)	0.20 (0.10-0.25)
M Stainless Steel	≤200HB	20 (15-30)	0.10 (0.05-0.15)	25 (15-30)	0.12 (0.05-0.15)	25 (15-30)	0.15 (0.10-0.20)	25 (15-30)	0.20 (0.10-0.25)
K Cast Iron	Tensile Strength ≤350N/mm ²	70 (40-85)	0.25 (0.15-0.30)	75 (50-90)	0.30 (0.20-0.35)	80 (50-95)	0.35 (0.20-0.40)	85 (55-95)	0.40 (0.30-0.45)
	Ductile Cast Iron Tensile Strength ≤450N/mm ²	65 (35-80)	0.20 (0.15-0.25)	70 (45-85)	0.25 (0.15-0.30)	75 (45-90)	0.30 (0.20-0.35)	80 (50-90)	0.35 (0.20-0.40)
N Aluminium Alloy	-	80 (70-90)	0.20 (0.10-0.25)	90 (80-100)	0.25 (0.15-0.30)	100 (90-110)	0.30 (0.20-0.35)	110 (100-120)	0.35 (0.20-0.40)
S Heat Resistant Alloy	-	20 (10-25)	0.10 (0.05-0.15)	25 (15-30)	0.12 (0.05-0.15)	25 (15-30)	0.15 (0.10-0.20)	30 (25-35)	0.20 (0.10-0.25)

MWS (Internal Coolant)

(3xD / 5xD / 8xD)

Work Material	Drill Diameter Conditions Hardness	φ3.0-φ6.0		φ6.0-φ10.0		φ10.0-φ14.0		φ14.0-φ25.0	
		Cutting Speed (m/min)	Feed (mm/rev)	Cutting Speed (m/min)	Feed (mm/rev)	Cutting Speed (m/min)	Feed (mm/rev)	Cutting Speed (m/min)	Feed (mm/rev)
P Mild Steel	≤180HB	110 (50-120)	0.20 (0.15-0.25)	130 (80-140)	0.25 (0.20-0.35)	150 (90-170)	0.30 (0.20-0.40)	160 (100-180)	0.35 (0.20-0.40)
	180-280HB	90 (50-100)	0.20 (0.15-0.25)	110 (70-120)	0.25 (0.20-0.35)	130 (80-140)	0.25 (0.20-0.40)	140 (100-150)	0.30 (0.20-0.40)
Carbon Steel Alloy Steel	280-350HB	80 (40-90)	0.20 (0.15-0.30)	90 (60-110)	0.25 (0.15-0.30)	110 (70-130)	0.25 (0.15-0.40)	120 (90-140)	0.30 (0.20-0.40)
	≤200HB	60 (20-100)	0.10 (0.05-0.15)	80 (40-120)	0.20 (0.10-0.25)	90 (50-120)	0.25 (0.15-0.30)	100 (60-120)	0.25 (0.15-0.30)
M Stainless Steel	≤200HB	60 (20-100)	0.10 (0.05-0.15)	80 (40-120)	0.20 (0.10-0.25)	90 (50-120)	0.25 (0.15-0.30)	100 (60-120)	0.25 (0.15-0.30)
K Cast Iron	Tensile Strength ≤350N/mm ²	100 (70-120)	0.25 (0.15-0.30)	130 (100-140)	0.30 (0.20-0.35)	150 (110-160)	0.35 (0.25-0.40)	160 (120-170)	0.35 (0.25-0.40)
	Ductile Cast Iron Tensile Strength ≤450N/mm ²	60 (30-80)	0.20 (0.15-0.25)	70 (40-90)	0.20 (0.15-0.30)	90 (50-110)	0.25 (0.20-0.40)	100 (60-110)	0.30 (0.20-0.40)
N Aluminium Alloy	-	120 (80-150)	0.25 (0.20-0.35)	150 (100-170)	0.30 (0.20-0.50)	160 (100-170)	0.40 (0.20-0.80)	170 (100-180)	0.50 (0.20-1.00)
S Heat Resistant Alloy	-	20 (10-25)	0.10 (0.05-0.15)	25 (15-30)	0.12 (0.05-0.15)	25 (15-30)	0.15 (0.10-0.20)	30 (25-35)	0.20 (0.10-0.25)

MWS Super Long Drill (Internal Coolant)

(10xD / 15xD / 20xD / 25xD / 30xD)

Work Material	Drill Dia. Conditions Hardness	φ3.0-φ6.0		φ6.0-φ10.0		φ10.0-φ14.0	
		Cutting Speed (m/min)	Feed (mm/rev)	Cutting Speed (m/min)	Feed (mm/rev)	Cutting Speed (m/min)	Feed (mm/rev)
P Mild Steel	≤180HB	90 (50-120)	0.20 (0.15-0.30)	110 (80-140)	0.25 (0.20-0.35)	130 (90-170)	0.30 (0.20-0.40)
	180-280HB	80 (50-100)	0.20 (0.15-0.30)	90 (70-120)	0.25 (0.20-0.35)	110 (80-140)	0.25 (0.20-0.40)
Carbon Steel Alloy Steel	280-350HB	70 (40-90)	0.20 (0.15-0.25)	80 (60-110)	0.25 (0.15-0.30)	90 (70-130)	0.25 (0.15-0.35)
	≤200HB	50 (20-100)	0.10 (0.05-0.15)	70 (40-120)	0.20 (0.10-0.25)	80 (50-120)	0.25 (0.15-0.30)
M Stainless Steel	≤200HB	50 (20-100)	0.10 (0.05-0.15)	70 (40-120)	0.20 (0.10-0.25)	80 (50-120)	0.25 (0.15-0.30)
K Cast Iron	Tensile Strength ≤350N/mm ²	90 (70-120)	0.25 (0.15-0.30)	110 (100-140)	0.30 (0.15-0.35)	130 (110-160)	0.35 (0.25-0.40)
	Ductile Cast Iron Tensile Strength ≤450N/mm ²	50 (30-80)	0.20 (0.15-0.25)	60 (40-90)	0.20 (0.15-0.30)	80 (50-110)	0.25 (0.20-0.40)
N Aluminium Alloy	-	100 (80-150)	0.25 (0.20-0.35)	130 (100-170)	0.30 (0.20-0.50)	140 (100-170)	0.40 (0.20-0.80)
S Heat Resistant Alloy	-	20 (10-25)	0.10 (0.05-0.15)	20 (15-30)	0.12 (0.05-0.15)	20 (15-30)	0.15 (0.10-0.20)

(Note 1) When drilling deeper than l/d=10, lower the cutting speed shown in the table above.

(Note 2) Be sure to drill a guide hole.

(Note 3) Raise to the above regular cutting revolution after inserting the long drill into the guide hole.

(Note 4) For pilot hole drilling, Mitsubishi's MPS drill is recommended.

HOW TO USE SUPER LONG DRILLS

● Drilling a blind hole

■ 1. Drilling a pilot hole

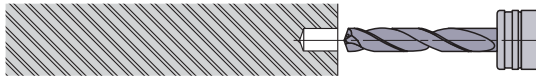

- ① Use a drill with a larger (flatter) point angle than the super long type. Mitsubishi type MPS is recommended.
- ② Use a drill with the same diameter as the deep hole drill.
- ③ Drill depth : Approx 2–3D or deeper.
(Adjust the pilot hole depth according to the length of the super long type.)

■ 2. Initial cutting with the long type drill

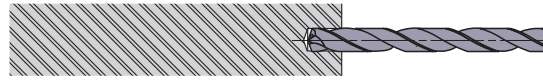

- ① Penetrate the pilot hole at low revolution. (Cutting speed 20–30m/min, feed rate 0.2–0.3mm/rev)
- ② Stop the long type drill 1–3mm short of the pilot hole bottom.

■ 3. Drill the deep hole

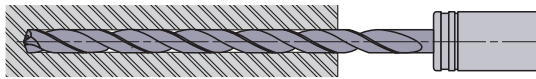

- ① Start cutting at the recommended speed and feed with a non-peck (continuous feed) cycle.

■ 4. Drill retraction

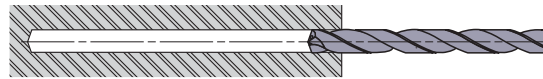

- ① After drilling, lower the cutting revolution about 1–2mm short of the hole end. (Cutting speed of around 20–30m/min)
- ② Retract the drill to the pilot hole depth starting point at a feed rate of 3000mm/min.
- ③ Finally, clear the hole at a cutting speed of 20–30m/min and feed rate of 0.2–0.3mm/rev.

● Drilling and breaking through on irregular faces or angles

■ 1. Spot facing

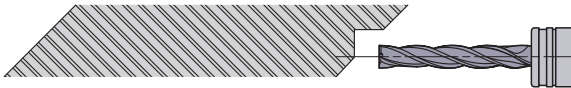

- ① Machine a flat or the irregular face by using an end mill or slot drill capable of spot facing. Make the spot face diameter the same size as the required deep hole diameter.

■ 2. Drilling a pilot hole

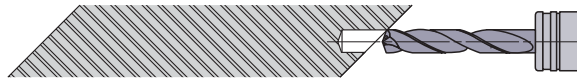

- ① Use a drill with a larger (flatter) point angle than the super long type. Mitsubishi type MPS is recommended.
- ② Use a drill with the same diameter as the deep hole drill.
- ③ Drill depth : Approx 2–3D or deeper.
(Adjust the pilot hole depth according to the length of the super long type.)

■ 3. Initial cutting with the long type drill

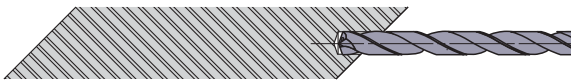

- ① Penetrate the pilot hole at a low revolution. (Cutting speed 20–30m/min, feed rate 0.2–0.3mm/rev)
- ② Stop the long type drill 1–3mm short of the pilot hole bottom.

■ 4. Drill the deep hole

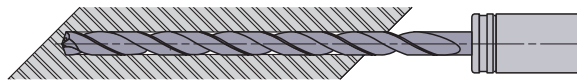

- ① Start cutting at the recommended speed and feed with a non-peck (continuous feed) cycle.

■ 5. Breaking through

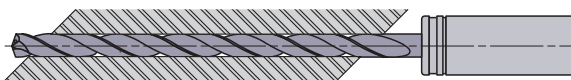

- ① When breaking through, the cutting edge can be damaged.
- ② A feed rate of 0.05–0.1mm/rev is recommended.

■ 6. Drill retraction

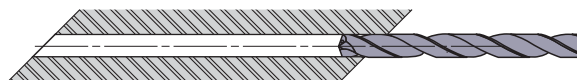

- ① Retract the drill to the pilot hole depth starting point at a feed rate of 3000mm/min.
- ② Finally clear the hole at a cutting speed of 20–30m/min and feed rate of 0.2–0.3mm/rev.



MPS

Double margin Solid Carbide drill for deep hole drilling up to 40xD. Innovative flute geometry for high precision.



PRECISION
FOR SUCCESS

CHOOSE JAPAN'S NO. 1

MITSUBISHI
MITSUBISHI MATERIALS

www.mitsubishicarbide.com

Features

- Wave type cutting edge for superior drilling performance
- Double margin flute for higher accuracy holes
- Available for drilling depths up to 40xD

Cutting edge shape

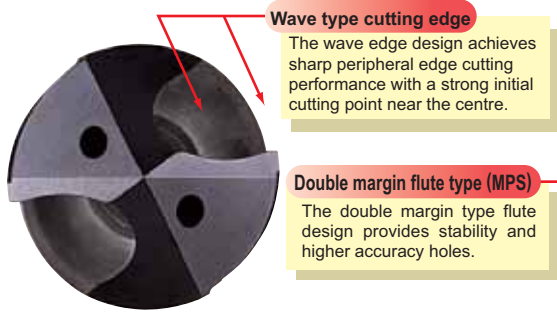

Cross sectional shape

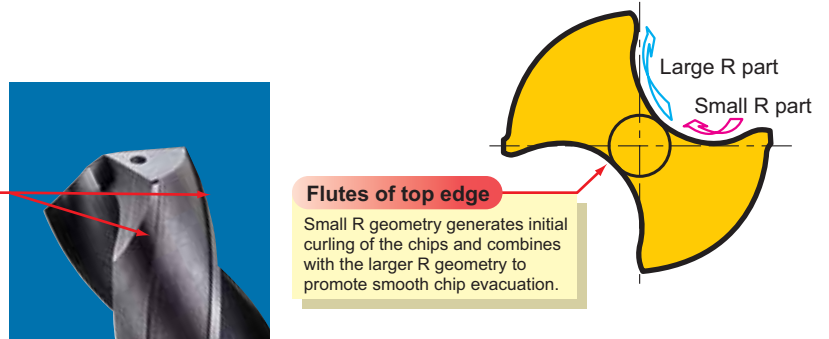

Excellent chip discharge

A special geometry at the top of the flute allows for superior chip control.

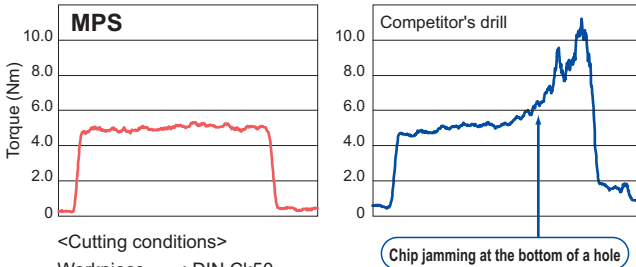

<Cutting conditions>

Workpiece : DIN Ck50
 Drill diameter : ø8mm
 Hole depth : 64mm (Through hole)
 Cutting speed : 120m/min
 Feed : 0.25mm/rev
 Coolant : WSO

Material technology

Long tool life **MIRACLE**® coated **VP15TF**

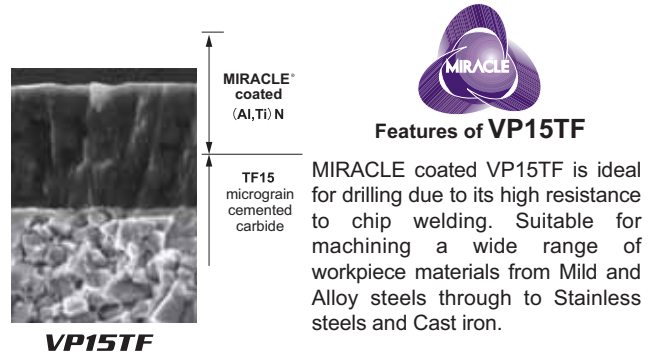

Features of VP15TF

MIRACLE coated VP15TF is ideal for drilling due to its high resistance to chip welding. Suitable for machining a wide range of workpiece materials from Mild and Alloy steels through to Stainless steels and Cast iron.

MPS DRILLS



DRILLING

A wide selection of drills

The range includes drills for hole depths from L/D = 3 - 40.

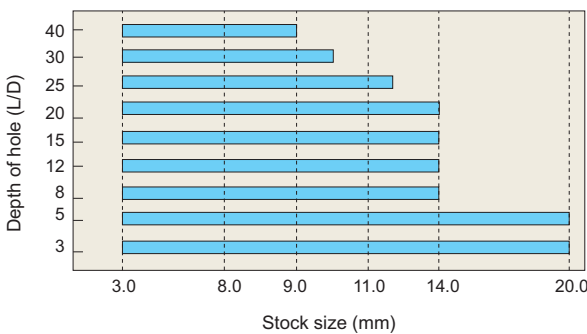

*Selected diameters only, see stock tables for details.
 Other diameters produced to order.

Long Tool Life

The special cutting edge geometry and advanced material technology provide high durability.

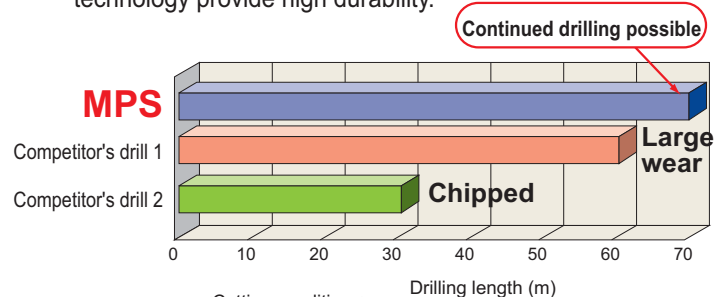

<Cutting conditions>

Workpiece : DIN Ck50
 Drill diameter : ø8mm
 Hole depth : 38mm (Through hole)
 Cutting speed : 140m/min
 Feed : 0.3mm/rev
 Coolant : WSO

● Centripetal top edge geometry

Top edge geometry

Centripetal top edge geometry with the small point angle and X-thinning achieves highly accurate hole positions! ($\theta_1 < \theta_2$)

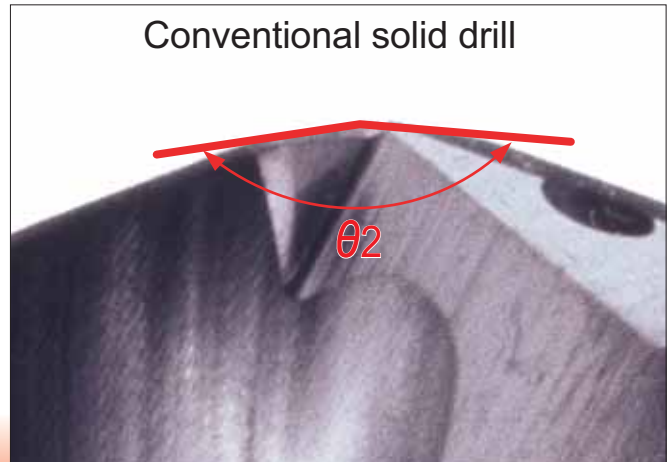
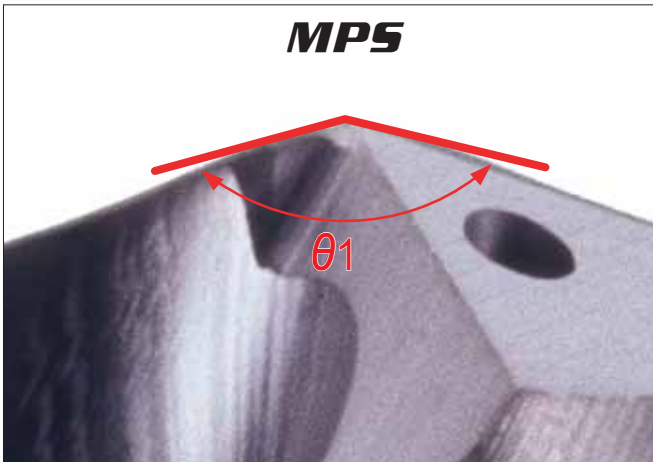

Cutting Performance

● High accuracy (Roundness)

MPS drill for hole roundness accuracy.

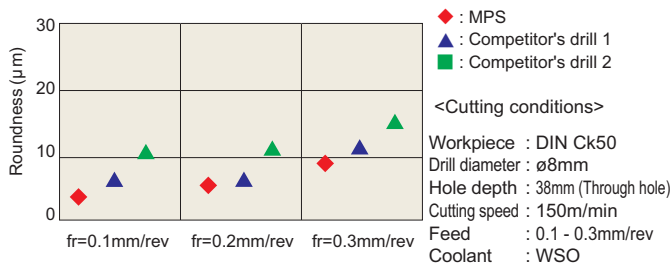

● High accuracy (Actual hole diameter)

The special cutting edge geometry and material technology ensures accurate hole sizes.

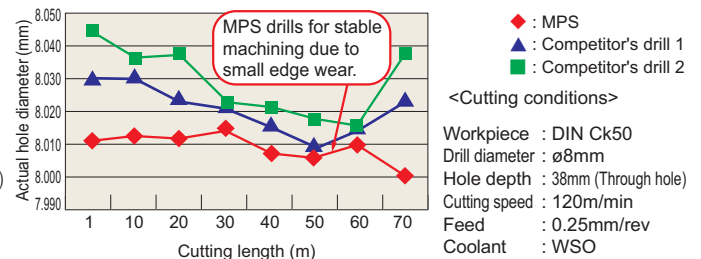

● Tool life

MPS-Drills are highly flank and margin wear resistant!

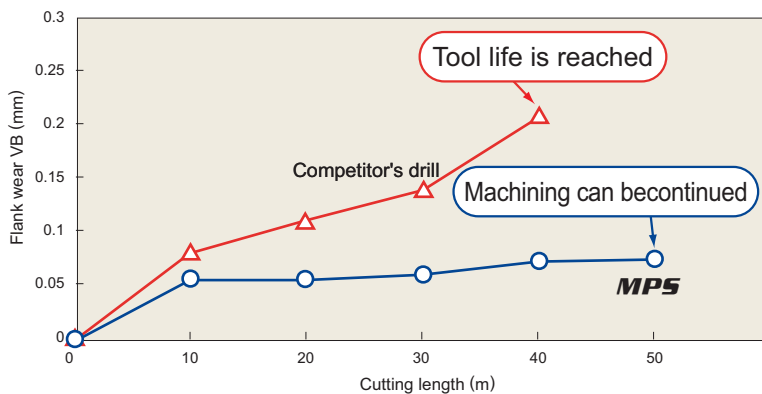

Enlarged picture of the margin after drilling 40m

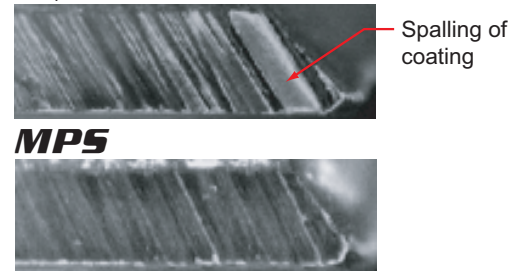

<Cutting conditions>
 Workpiece : Cf53 (1.1213)
 Hardness : 150-180HB
 Drill diameter : ø8 (Internal coolant)
 Coolant : Emulsion 10%
 Cutting speed : 80m/min
 Feed : 0.2mm/rev
 Hole depth : 25mm (Through hole)



DRILLING (SOLID CARBIDE)

MPS

- From 3—40 l/d hole depth.
- MPS double margin type for accurate and reliable drilling.
- All drills with through coolant holes as standard.



D1 Tolerance	3.0 ≤ D1 ≤ 6.0	6.0 < D1 ≤ 10.0	10.0 < D1 ≤ 18.0	18.0 < D1 ≤ 20.0
DIN type	0.010 -0.002	0.010 -0.005	0.005 -0.013	0.005 -0.016
Others	0 -0.012	0 -0.015	0 -0.018	0 -0.021

* MPS-DIN type see table above. Other MPS drills h7 tolerance.

● Type A Double margin type

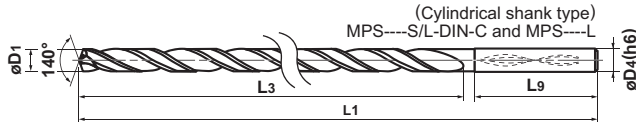

MPS---S/L-DIN (l/d 3—5)

MPS---S/L-DIN-C (l/d 3—5)

MPS---L (l/d 8—40)

(Whistle notch shank type)

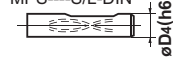

Drill Dia. D1 (mm)	Hole Depth (l/d)	Stock VP15TF	Order Number	Dimensions (mm)				Type
				L1	L3	L9	D4	
3.0	3	●	MPS0300S-DIN	62	20	36	6	A
	3	●	MPS0300S-DIN-C	62	20	36	6	A
	5	●	MPS0300L-DIN	66	28	36	6	A
	5	●	MPS0300L-DIN-C	66	28	36	6	A
	8	●	MPS0300-L8C	74	34	36	6	A
	10	□	MPS0300-L10C	80	40	36	6	A
	12	●	MPS0300-L12C	86	46	36	6	A
	15	●	MPS0300-L15C	95	55	36	6	A
	20	□	MPS0300-L20C	110	70	36	6	A
	25	□	MPS0300-L25C	125	85	36	6	A
30	□	MPS0300-L30C	140	100	36	6	A	
NEW 40	●	MPS0300-L40C	174	131	36	6	A	
3.05	3	●	MPS0305S-DIN	62	20	36	6	A
	3	●	MPS0305S-DIN-C	62	20	36	6	A
	5	●	MPS0305L-DIN	66	28	36	6	A
	5	●	MPS0305L-DIN-C	66	28	36	6	A
	5	●	MPS0305L-DIN-C	66	28	36	6	A
3.1	3	●	MPS0310S-DIN	62	20	36	6	A
	3	●	MPS0310S-DIN-C	62	20	36	6	A
	5	●	MPS0310L-DIN	66	28	36	6	A
	5	●	MPS0310L-DIN-C	66	28	36	6	A
	8	●	MPS0310-L8C	80	40	36	6	A
	10	□	MPS0310-L10C	87	47	36	6	A
	12	●	MPS0310-L12C	94	54	36	6	A
	15	●	MPS0310-L15C	104	64	36	6	A
	20	□	MPS0310-L20C	122	82	36	6	A
	25	□	MPS0310-L25C	139	99	36	6	A
30	□	MPS0310-L30C	157	117	36	6	A	
NEW 40	□	MPS0310-L40C	191	141	36	6	A	
3.2	3	●	MPS0320S-DIN	62	20	36	6	A
	3	●	MPS0320S-DIN-C	62	20	36	6	A
	5	●	MPS0320L-DIN	66	28	36	6	A
	5	●	MPS0320L-DIN-C	66	28	36	6	A
	8	●	MPS0320-L8C	80	40	36	6	A
	10	□	MPS0320-L10C	87	47	36	6	A
	12	●	MPS0320-L12C	94	54	36	6	A
	15	●	MPS0320-L15C	104	64	36	6	A
	20	□	MPS0320-L20C	122	82	36	6	A
	25	□	MPS0320-L25C	139	99	36	6	A
30	□	MPS0320-L30C	157	117	36	6	A	
NEW 40	□	MPS0320-L40C	191	141	36	6	A	

Drill Dia. D1 (mm)	Hole Depth (l/d)	Stock VP15TF	Order Number	Dimensions (mm)				Type
				L1	L3	L9	D4	
3.3	3	●	MPS0330S-DIN	62	20	36	6	A
	3	●	MPS0330S-DIN-C	62	20	36	6	A
	5	●	MPS0330L-DIN	66	28	36	6	A
	5	●	MPS0330L-DIN-C	66	28	36	6	A
	8	●	MPS0330-L8C	80	40	36	6	A
	10	□	MPS0330-L10C	87	47	36	6	A
	12	●	MPS0330-L12C	94	54	36	6	A
	15	●	MPS0330-L15C	104	64	36	6	A
	20	□	MPS0330-L20C	122	82	36	6	A
	25	□	MPS0330-L25C	139	99	36	6	A
30	□	MPS0330-L30C	157	117	36	6	A	
NEW 40	□	MPS0330-L40C	191	151	36	6	A	
3.4	3	●	MPS0340S-DIN	62	20	36	6	A
	3	●	MPS0340S-DIN-C	62	20	36	6	A
	5	●	MPS0340L-DIN	66	28	36	6	A
	5	●	MPS0340L-DIN-C	66	28	36	6	A
	8	●	MPS0340-L8C	80	40	36	6	A
	10	□	MPS0340-L10C	87	47	36	6	A
	12	●	MPS0340-L12C	94	54	36	6	A
	15	●	MPS0340-L15C	104	64	36	6	A
	20	□	MPS0340-L20C	122	82	36	6	A
	25	□	MPS0340-L25C	139	99	36	6	A
30	□	MPS0340-L30C	157	117	36	6	A	
NEW 40	□	MPS0340-L40C	191	151	36	6	A	
3.5	3	●	MPS0350S-DIN	62	20	36	6	A
	3	●	MPS0350S-DIN-C	62	20	36	6	A
	5	●	MPS0350L-DIN	66	28	36	6	A
	5	●	MPS0350L-DIN-C	66	28	36	6	A
	8	●	MPS0350-L8C	80	40	36	6	A
	10	□	MPS0350-L10C	87	47	36	6	A
	12	●	MPS0350-L12C	94	54	36	6	A
	15	●	MPS0350-L15C	104	64	36	6	A
	20	□	MPS0350-L20C	122	82	36	6	A
	25	□	MPS0350-L25C	139	99	36	6	A
30	□	MPS0350-L30C	157	117	36	6	A	
NEW 40	●	MPS0350-L40C	191	151	36	6	A	

DRILLING MPS DRILLS



Ø 3.0 ~ 3.5

- : Stock Standard
- ★ : Stock Standard in Japan.
- : Non stock, produced to order only

Drill Dia. D1 (mm)	Hole Depth (l/d)	Stock		Order Number	Dimensions (mm)				Type
		VP15TF			L1	L3	L9	D4	
3.6	3	●		MPS0360S-DIN	62	20	36	6	A
	3	●		MPS0360S-DIN-C	62	20	36	6	A
	5	●		MPS0360L-DIN	66	28	36	6	A
	5	●		MPS0360L-DIN-C	66	28	36	6	A
	8	●		MPS0360-L8C	85	45	36	6	A
	10	□		MPS0360-L10C	93	53	36	6	A
	12	●		MPS0360-L12C	101	61	36	6	A
	15	●		MPS0360-L15C	113	73	36	6	A
	20	□		MPS0360-L20C	133	93	36	6	A
	25	□		MPS0360-L25C	153	113	36	6	A
3.7	30	□		MPS0360-L30C	173	133	36	6	A
	40	□		MPS0360-L40C	213	163	36	6	A
	3	●		MPS0370S-DIN	62	20	36	6	A
	3	●		MPS0370S-DIN-C	62	20	36	6	A
	5	●		MPS0370L-DIN	66	28	36	6	A
	5	●		MPS0370L-DIN-C	66	28	36	6	A
	8	●		MPS0370-L8C	85	45	36	6	A
	10	□		MPS0370-L10C	93	53	36	6	A
	12	●		MPS0370-L12C	101	61	36	6	A
	15	●		MPS0370-L15C	113	73	36	6	A
3.8	20	□		MPS0370-L20C	133	93	36	6	A
	25	□		MPS0370-L25C	153	113	36	6	A
	30	□		MPS0370-L30C	173	133	36	6	A
	40	□		MPS0370-L40C	213	163	36	6	A
	3	●		MPS0380S-DIN	66	24	36	6	A
	3	●		MPS0380S-DIN-C	66	24	36	6	A
	5	●		MPS0380L-DIN	74	36	36	6	A
	5	●		MPS0380L-DIN-C	74	36	36	6	A
	8	●		MPS0380-L8C	85	45	36	6	A
	10	□		MPS0380-L10C	93	53	36	6	A
3.9	12	●		MPS0380-L12C	101	61	36	6	A
	15	●		MPS0380-L15C	113	73	36	6	A
	20	□		MPS0380-L20C	133	93	36	6	A
	25	□		MPS0380-L25C	153	113	36	6	A
	30	□		MPS0380-L30C	173	133	36	6	A
	40	□		MPS0380-L40C	213	173	36	6	A
	3	●		MPS0390S-DIN	66	24	36	6	A
	3	●		MPS0390S-DIN-C	66	24	36	6	A
	5	●		MPS0390L-DIN	74	36	36	6	A
	5	●		MPS0390L-DIN-C	74	36	36	6	A
8	●		MPS0390-L8C	85	45	36	6	A	
10	●		MPS0390-L10C	93	53	36	6	A	
12	●		MPS0390-L12C	101	61	36	6	A	
15	●		MPS0390-L15C	113	73	36	6	A	
4.0	20	□		MPS0390-L20C	133	93	36	6	A
	25	●		MPS0390-L25C	153	113	36	6	A
	30	●		MPS0390-L30C	173	133	36	6	A
	40	□		MPS0390-L40C	213	173	36	6	A
	3	●		MPS0400S-DIN	66	24	36	6	A
	3	●		MPS0400S-DIN-C	66	24	36	6	A
	5	●		MPS0400L-DIN	74	36	36	6	A
	5	●		MPS0400L-DIN-C	74	36	36	6	A
	8	●		MPS0400-L8C	85	45	36	6	A
	10	□		MPS0400-L10C	93	53	36	6	A
12	●		MPS0400-L12C	101	61	36	6	A	
15	●		MPS0400-L15C	113	73	36	6	A	

Drill Dia. D1 (mm)	Hole Depth (l/d)	Stock		Order Number	Dimensions (mm)				Type
		VP15TF			L1	L3	L9	D4	
4.0	20	□		MPS0400-L20C	133	93	36	6	A
	25	□		MPS0400-L25C	153	113	36	6	A
	30	□		MPS0400-L30C	173	133	36	6	A
	40	●		MPS0400-L40C	213	173	36	6	A
4.05	3	●		MPS0405S-DIN	66	24	36	6	A
	3	●		MPS0405S-DIN-C	66	24	36	6	A
	5	●		MPS0405L-DIN	74	36	36	6	A
	5	●		MPS0405L-DIN-C	74	36	36	6	A
	5	●		MPS0405L-DIN-C	74	36	36	6	A
4.1	3	●		MPS0410S-DIN	66	24	36	6	A
	3	●		MPS0410S-DIN-C	66	24	36	6	A
	5	●		MPS0410L-DIN	74	36	36	6	A
	5	●		MPS0410L-DIN-C	74	36	36	6	A
	8	●		MPS0410-L8C	91	51	36	6	A
	10	□		MPS0410-L10C	100	60	36	6	A
	12	●		MPS0410-L12C	109	69	36	6	A
	15	●		MPS0410-L15C	122	82	36	6	A
	20	□		MPS0410-L20C	145	105	36	6	A
	25	□		MPS0410-L25C	167	127	36	6	A
4.2	30	□		MPS0410-L30C	190	150	36	6	A
	40	□		MPS0410-L40C	236	186	36	6	A
	3	●		MPS0420S-DIN	66	24	36	6	A
	3	●		MPS0420S-DIN-C	66	24	36	6	A
	5	●		MPS0420L-DIN	74	36	36	6	A
	5	●		MPS0420L-DIN-C	74	36	36	6	A
	8	●		MPS0420-L8C	91	51	36	6	A
	10	□		MPS0420-L10C	100	60	36	6	A
	12	●		MPS0420-L12C	109	69	36	6	A
	15	●		MPS0420-L15C	122	82	36	6	A
4.3	20	□		MPS0420-L20C	145	105	36	6	A
	25	□		MPS0420-L25C	167	127	36	6	A
	30	□		MPS0420-L30C	190	150	36	6	A
	40	●		MPS0420-L40C	236	186	36	6	A
	3	●		MPS0430S-DIN	66	24	36	6	A
	3	●		MPS0430S-DIN-C	66	24	36	6	A
	5	●		MPS0430L-DIN	74	36	36	6	A
	5	●		MPS0430L-DIN-C	74	36	36	6	A
	8	●		MPS0430-L8C	91	51	36	6	A
	10	□		MPS0430-L10C	100	60	36	6	A
4.4	12	●		MPS0430-L12C	109	69	36	6	A
	15	●		MPS0430-L15C	122	82	36	6	A
	20	□		MPS0430-L20C	145	105	36	6	A
	25	□		MPS0430-L25C	167	127	36	6	A
	30	□		MPS0430-L30C	190	150	36	6	A
	40	□		MPS0430-L40C	236	196	36	6	A
	3	●		MPS0440S-DIN	66	24	36	6	A
	3	●		MPS0440S-DIN-C	66	24	36	6	A
	5	●		MPS0440L-DIN	74	36	36	6	A
	5	●		MPS0440L-DIN-C	74	36	36	6	A
8	●		MPS0440-L8C	91	51	36	6	A	
10	□		MPS0440-L10C	100	60	36	6	A	
12	●		MPS0440-L12C	109	69	36	6	A	
15	●		MPS0440-L15C	122	82	36	6	A	
4.4	20	□		MPS0440-L20C	145	105	36	6	A
	25	□		MPS0440-L25C	167	127	36	6	A
	30	□		MPS0440-L30C	190	150	36	6	A
	40	□		MPS0440-L40C	236	196	36	6	A

DRILLING MPS DRILLS

Ø 3.6 ~ 4.4

CUTTING CONDITIONS

D078

D063

DRILLING (SOLID CARBIDE)

MPS

- From 3—40 l/d hole depth.
- MPS double margin type for accurate and reliable drilling.
- All drills with through coolant holes as standard.



D1 Tolerance	6.0 < D1 ≤ 10.0	10.0 < D1 ≤ 18.0	18.0 < D1 ≤ 20.0
DIN type	0.010 -0.002	0.010 -0.005	0.005 -0.013 0.005 -0.016
Others	0 -0.012	0 -0.015	0 -0.018 0 -0.021

* MPS-DIN type see table above. Other MPS drills h7 tolerance.

● Type A Double margin type

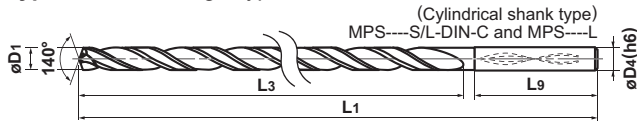

MPS---S/L-DIN (l/d 3—5)

MPS---S/L-DIN-C (l/d 3—5)

MPS---L (l/d 8—40)

(Whistle notch shank type)

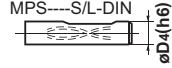

DRILLING MPS DRILLS

Ø 4.5 ~ 5.05

Drill Dia. D1 (mm)	Hole Depth (l/d)	Stock		Order Number	Dimensions (mm)				Type
		VP15TF			L1	L3	L9	D4	
4.5	3	●		MPS0450S-DIN	66	24	36	6	A
	3	●		MPS0450S-DIN-C	66	24	36	6	A
	5	●		MPS0450L-DIN	74	36	36	6	A
	5	●		MPS0450L-DIN-C	74	36	36	6	A
	8	●		MPS0450-L8C	91	51	36	6	A
	10	□		MPS0450-L10C	100	60	36	6	A
	12	●		MPS0450-L12C	109	69	36	6	A
	15	●		MPS0450-L15C	122	82	36	6	A
	20	□		MPS0450-L20C	145	105	36	6	A
	25	□		MPS0450-L25C	167	127	36	6	A
30	□		MPS0450-L30C	190	150	36	6	A	
NEW	40	●		MPS0450-L40C	236	196	36	6	A
4.6	3	●		MPS0460S-DIN	66	24	36	6	A
	3	●		MPS0460S-DIN-C	66	24	36	6	A
	5	●		MPS0460L-DIN	74	36	36	6	A
	5	●		MPS0460L-DIN-C	74	36	36	6	A
	8	●		MPS0460-L8C	96	55	36	6	A
	10	□		MPS0460-L10C	106	66	36	6	A
	12	●		MPS0460-L12C	116	76	36	6	A
	15	●		MPS0460-L15C	131	91	36	6	A
	20	□		MPS0460-L20C	156	116	36	6	A
	25	□		MPS0460-L25C	181	141	36	6	A
30	□		MPS0460-L30C	206	166	36	6	A	
NEW	40	□		MPS0460-L40C	255	205	36	6	A
4.65	3	●		MPS0465S-DIN	66	24	36	6	A
	3	●		MPS0465S-DIN-C	66	24	36	6	A
	5	●		MPS0465L-DIN	74	36	36	6	A
	5	●		MPS0465L-DIN-C	74	36	36	6	A
4.7	3	●		MPS0470S-DIN	66	24	36	6	A
	3	●		MPS0470S-DIN-C	66	24	36	6	A
	5	●		MPS0470L-DIN	74	36	36	6	A
	5	●		MPS0470L-DIN-C	74	36	36	6	A
	8	●		MPS0470-L8C	96	55	36	6	A
	10	□		MPS0470-L10C	106	66	36	6	A
	12	●		MPS0470-L12C	116	76	36	6	A
	15	●		MPS0470-L15C	131	91	36	6	A
	20	□		MPS0470-L20C	156	116	36	6	A
	25	□		MPS0470-L25C	181	141	36	6	A
	30	□		MPS0470-L30C	206	166	36	6	A
	NEW	40	□		MPS0470-L40C	255	205	36	6

Drill Dia. D1 (mm)	Hole Depth (l/d)	Stock		Order Number	Dimensions (mm)				Type
		VP15TF			L1	L3	L9	D4	
4.8	3	●		MPS0480S-DIN	66	28	36	6	A
	3	●		MPS0480S-DIN-C	66	28	36	6	A
	5	●		MPS0480L-DIN	82	44	36	6	A
	5	●		MPS0480L-DIN-C	82	44	36	6	A
	8	●		MPS0480-L8C	96	55	36	6	A
	10	□		MPS0480-L10C	106	66	36	6	A
	12	●		MPS0480-L12C	116	76	36	6	A
	15	●		MPS0480-L15C	131	91	36	6	A
	20	□		MPS0480-L20C	156	116	36	6	A
	25	□		MPS0480-L25C	181	141	36	6	A
30	□		MPS0480-L30C	206	166	36	6	A	
NEW	40	□		MPS0480-L40C	255	216	36	6	A
4.9	3	●		MPS0490S-DIN	66	28	36	6	A
	3	●		MPS0490S-DIN-C	66	28	36	6	A
	5	●		MPS0490L-DIN	82	44	36	6	A
	5	●		MPS0490L-DIN-C	82	44	36	6	A
	8	●		MPS0490-L8C	96	55	36	6	A
	10	□		MPS0490-L10C	106	66	36	6	A
	12	●		MPS0490-L12C	116	76	36	6	A
	15	●		MPS0490-L15C	131	91	36	6	A
	20	□		MPS0490-L20C	156	116	36	6	A
	25	□		MPS0490-L25C	181	141	36	6	A
30	□		MPS0490-L30C	206	166	36	6	A	
NEW	40	□		MPS0490-L40C	255	216	36	6	A
5.0	3	●		MPS0500S-DIN	66	28	36	6	A
	3	●		MPS0500S-DIN-C	66	28	36	6	A
	5	●		MPS0500L-DIN	82	44	36	6	A
	5	●		MPS0500L-DIN-C	82	44	36	6	A
	8	●		MPS0500-L8C	96	55	36	6	A
	10	□		MPS0500-L10C	106	66	36	6	A
	12	●		MPS0500-L12C	116	76	36	6	A
	15	●		MPS0500-L15C	131	91	36	6	A
	20	□		MPS0500-L20C	156	116	36	6	A
	25	□		MPS0500-L25C	181	141	36	6	A
	30	□		MPS0500-L30C	206	166	36	6	A
	NEW	40	●		MPS0500-L40C	255	216	36	6
5.05	3	●		MPS0505S-DIN	66	28	36	6	A
	3	●		MPS0505S-DIN-C	66	28	36	6	A
	5	●		MPS0505L-DIN	82	44	36	6	A
	5	●		MPS0505L-DIN-C	82	44	36	6	A

- : Stock Standard
- ★ : Stock Standard in Japan.
- : Non stock, produced to order only

Drill Dia. D1 (mm)	Hole Depth (l/d)	Stock		Order Number	Dimensions (mm)				Type
		VP15TF			L1	L3	L9	D4	
5.1	3	●		MPS0510S-DIN	66	28	36	6	A
	3	●		MPS0510S-DIN-C	66	28	36	6	A
	5	●		MPS0510L-DIN	82	44	36	6	A
	5	●		MPS0510L-DIN-C	82	44	36	6	A
	8	●		MPS0510-L8C	102	62	36	6	A
	10	□		MPS0510-L10C	113	73	36	6	A
	12	●		MPS0510-L12C	124	84	36	6	A
	15	●		MPS0510-L15C	140	100	36	6	A
	20	□		MPS0510-L20C	168	128	36	6	A
	25	□		MPS0510-L25C	195	155	36	6	A
NEW	30	□		MPS0510-L30C	223	183	36	6	A
	40	□		MPS0510-L40C	279	231	36	6	A
5.2	3	●		MPS0520S-DIN	66	28	36	6	A
	3	●		MPS0520S-DIN-C	66	28	36	6	A
	5	●		MPS0520L-DIN	82	44	36	6	A
	5	●		MPS0520L-DIN-C	82	44	36	6	A
	8	●		MPS0520-L8C	102	62	36	6	A
	10	□		MPS0520-L10C	113	73	36	6	A
	12	●		MPS0520-L12C	124	84	36	6	A
	15	●		MPS0520-L15C	140	100	36	6	A
	20	□		MPS0520-L20C	168	128	36	6	A
	25	□		MPS0520-L25C	195	155	36	6	A
NEW	30	□		MPS0520-L30C	223	183	36	6	A
	40	□		MPS0520-L40C	279	231	36	6	A
5.3	3	●		MPS0530S-DIN	66	28	36	6	A
	3	●		MPS0530S-DIN-C	66	28	36	6	A
	5	●		MPS0530L-DIN	82	44	36	6	A
	5	●		MPS0530L-DIN-C	82	44	36	6	A
	8	●		MPS0530-L8C	102	62	36	6	A
	10	□		MPS0530-L10C	113	73	36	6	A
	12	●		MPS0530-L12C	124	84	36	6	A
	15	●		MPS0530-L15C	140	100	36	6	A
	20	□		MPS0530-L20C	168	128	36	6	A
	25	□		MPS0530-L25C	195	155	36	6	A
NEW	30	□		MPS0530-L30C	223	183	36	6	A
	40	□		MPS0530-L40C	279	241	36	6	A
5.4	3	●		MPS0540S-DIN	66	28	36	6	A
	3	●		MPS0540S-DIN-C	66	28	36	6	A
	5	●		MPS0540L-DIN	82	44	36	6	A
	5	●		MPS0540L-DIN-C	82	44	36	6	A
	8	●		MPS0540-L8C	102	62	36	6	A
	10	□		MPS0540-L10C	113	73	36	6	A
	12	●		MPS0540-L12C	124	84	36	6	A
	15	●		MPS0540-L15C	140	100	36	6	A
	20	□		MPS0540-L20C	168	128	36	6	A
	25	□		MPS0540-L25C	195	155	36	6	A
NEW	30	□		MPS0540-L30C	223	183	36	6	A
	40	□		MPS0540-L40C	279	241	36	6	A
5.5	3	●		MPS0550S-DIN	66	28	36	6	A
	3	●		MPS0550S-DIN-C	66	28	36	6	A
	5	●		MPS0550L-DIN	82	44	36	6	A
	5	●		MPS0550L-DIN-C	82	44	36	6	A
	8	●		MPS0550-L8C	102	62	36	6	A
	10	□		MPS0550-L10C	113	73	36	6	A
	12	●		MPS0550-L12C	124	84	36	6	A
15	●		MPS0550-L15C	140	100	36	6	A	

Drill Dia. D1 (mm)	Hole Depth (l/d)	Stock		Order Number	Dimensions (mm)				Type
		VP15TF			L1	L3	L9	D4	
5.5	20	□		MPS0550-L20C	168	128	36	6	A
	25	□		MPS0550-L25C	195	155	36	6	A
	30	□		MPS0550-L30C	223	183	36	6	A
	NEW	40	●	MPS0550-L40C	279	241	36	6	A
5.55	3	●		MPS0555S-DIN	66	28	36	6	A
	3	●		MPS0555S-DIN-C	66	28	36	6	A
	5	●		MPS0555L-DIN	82	44	36	6	A
	5	●		MPS0555L-DIN-C	82	44	36	6	A
5.6	3	●		MPS0560S-DIN	66	28	36	6	A
	3	●		MPS0560S-DIN-C	66	28	36	6	A
	5	●		MPS0560L-DIN	82	44	36	6	A
	5	●		MPS0560L-DIN-C	82	44	36	6	A
	8	●		MPS0560-L8C	107	67	36	6	A
	10	□		MPS0560-L10C	119	79	36	6	A
	12	●		MPS0560-L12C	131	91	36	6	A
	15	●		MPS0560-L15C	149	109	36	6	A
	20	□		MPS0560-L20C	179	139	36	6	A
	25	□		MPS0560-L25C	209	169	36	6	A
NEW	30	□		MPS0560-L30C	239	199	36	6	A
	40	□		MPS0560-L40C	299	251	36	6	A
5.7	3	●		MPS0570S-DIN	66	28	36	6	A
	3	●		MPS0570S-DIN-C	66	28	36	6	A
	5	●		MPS0570L-DIN	82	44	36	6	A
	5	●		MPS0570L-DIN-C	82	44	36	6	A
	8	●		MPS0570-L8C	107	67	36	6	A
	10	□		MPS0570-L10C	119	79	36	6	A
	12	●		MPS0570-L12C	131	91	36	6	A
	15	●		MPS0570-L15C	149	109	36	6	A
	20	□		MPS0570-L20C	179	139	36	6	A
	25	□		MPS0570-L25C	209	169	36	6	A
NEW	30	□		MPS0570-L30C	239	199	36	6	A
	40	□		MPS0570-L40C	299	251	36	6	A
5.8	3	●		MPS0580S-DIN	66	28	36	6	A
	3	●		MPS0580S-DIN-C	66	28	36	6	A
	5	●		MPS0580L-DIN	82	44	36	6	A
	5	●		MPS0580L-DIN-C	82	44	36	6	A
	8	●		MPS0580-L8C	107	67	36	6	A
	10	□		MPS0580-L10C	119	79	36	6	A
	12	●		MPS0580-L12C	131	91	36	6	A
	15	●		MPS0580-L15C	149	109	36	6	A
	20	□		MPS0580-L20C	179	139	36	6	A
	25	□		MPS0580-L25C	209	169	36	6	A
NEW	30	□		MPS0580-L30C	239	199	36	6	A
	40	□		MPS0580-L40C	299	261	36	6	A
5.9	3	●		MPS0590S-DIN	66	28	36	6	A
	3	●		MPS0590S-DIN-C	66	28	36	6	A
	5	●		MPS0590L-DIN	82	44	36	6	A
	5	●		MPS0590L-DIN-C	82	44	36	6	A
	8	●		MPS0590-L8C	107	67	36	6	A
	10	□		MPS0590-L10C	119	79	36	6	A
	12	●		MPS0590-L12C	131	91	36	6	A
	15	●		MPS0590-L15C	149	109	36	6	A
	20	□		MPS0590-L20C	179	139	36	6	A
	25	□		MPS0590-L25C	209	169	36	6	A
NEW	30	□		MPS0590-L30C	239	199	36	6	A
	40	□		MPS0590-L40C	299	261	36	6	A

MPS DRILLS



Ø 5.1 ~ 5.9

CUTTING CONDITIONS

D078

D065

DRILLING (SOLID CARBIDE)

MPS

- From 3—40 l/d hole depth.
- MPS double margin type for accurate and reliable drilling.
- All drills with through coolant holes as standard.



D1 Tolerance	3.0≤D1≤6.0	6.0<D1≤10.0	10.0<D1≤18.0	18.0<D1≤20.0
DIN type	0.010 -0.002	0.010 -0.005	0.005 -0.013	0.005 -0.016
Others	0 -0.012	0 -0.015	0 -0.018	0 -0.021

* MPS-DIN type see table above. Other MPS drills h7 tolerance.

● Type A Double margin type

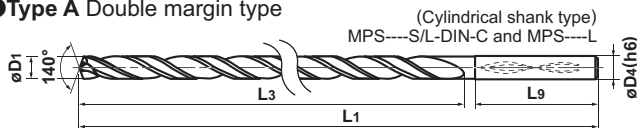

- MPS---S/L-DIN (l/d 3—5)
- MPS---S/L-DIN-C (l/d 3—5)
- MPS---L (l/d 8—40)

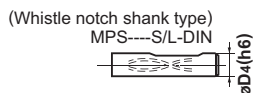

DRILLING MPS DRILLS

Drill Dia. D1 (mm)	Hole Depth (l/d)	Stock VP15TF	Order Number	Dimensions (mm)				Type
				L1	L3	L9	D4	
6.0	3	●	MPS0600S-DIN	66	28	36	6	A
	3	●	MPS0600S-DIN-C	66	28	36	6	A
	5	●	MPS0600L-DIN	82	44	36	6	A
	5	●	MPS0600L-DIN-C	82	44	36	6	A
	8	●	MPS0600-L8C	107	67	36	6	A
	10	□	MPS0600-L10C	119	79	36	6	A
	12	●	MPS0600-L12C	131	91	36	6	A
	15	●	MPS0600-L15C	149	109	36	6	A
	20	□	MPS0600-L20C	179	139	36	6	A
	25	□	MPS0600-L25C	209	169	36	6	A
30	□	MPS0600-L30C	239	199	36	6	A	
NEW 40	●	MPS0600-L40C	299	261	36	6	A	
6.05	3	●	MPS0605S-DIN	79	34	36	8	A
	3	●	MPS0605S-DIN-C	79	34	36	8	A
	5	●	MPS0605L-DIN	91	53	36	8	A
	5	●	MPS0605L-DIN-C	91	53	36	8	A
6.1	3	●	MPS0610S-DIN	79	34	36	8	A
	3	●	MPS0610S-DIN-C	79	34	36	8	A
	5	●	MPS0610L-DIN	91	53	36	8	A
	5	●	MPS0610L-DIN-C	91	53	36	8	A
	8	●	MPS0610-L8C	113	73	36	8	A
	10	□	MPS0610-L10C	126	86	36	8	A
	12	●	MPS0610-L12C	139	99	36	8	A
	15	●	MPS0610-L15C	158	118	36	8	A
	20	□	MPS0610-L20C	191	151	36	8	A
	25	□	MPS0610-L25C	223	183	36	8	A
30	□	MPS0610-L30C	256	216	36	8	A	
NEW 40	□	MPS0610-L40C	321	271	36	8	A	
6.2	3	●	MPS0620S-DIN	79	34	36	8	A
	3	●	MPS0620S-DIN-C	79	34	36	8	A
	5	●	MPS0620L-DIN	91	53	36	8	A
	5	●	MPS0620L-DIN-C	91	53	36	8	A
	8	●	MPS0620-L8C	113	76	36	8	A
	10	□	MPS0620-L10C	126	86	36	8	A
	12	●	MPS0620-L12C	139	99	36	8	A
	15	●	MPS0620-L15C	158	118	36	8	A
	20	□	MPS0620-L20C	191	151	36	8	A
	25	□	MPS0620-L25C	223	183	36	8	A
30	□	MPS0620-L30C	256	216	36	8	A	
NEW 40	□	MPS0620-L40C	321	271	36	8	A	

Drill Dia. D1 (mm)	Hole Depth (l/d)	Stock VP15TF	Order Number	Dimensions (mm)				Type
				L1	L3	L9	D4	
6.3	3	●	MPS0630S-DIN	79	34	36	8	A
	3	●	MPS0630S-DIN-C	79	34	36	8	A
	5	●	MPS0630L-DIN	91	53	36	8	A
	5	●	MPS0630L-DIN-C	91	53	36	8	A
	8	●	MPS0630-L8C	113	73	36	8	A
	10	□	MPS0630-L10C	126	86	36	8	A
	12	●	MPS0630-L12C	139	99	36	8	A
	15	●	MPS0630-L15C	158	118	36	8	A
	20	□	MPS0630-L20C	191	151	36	8	A
	25	□	MPS0630-L25C	223	183	36	8	A
30	□	MPS0630-L30C	256	216	36	8	A	
NEW 40	□	MPS0630-L40C	321	281	36	8	A	
6.4	3	●	MPS0640S-DIN	79	34	36	8	A
	3	●	MPS0640S-DIN-C	79	34	36	8	A
	5	●	MPS0640L-DIN	91	53	36	8	A
	5	●	MPS0640L-DIN-C	91	53	36	8	A
	8	●	MPS0640-L8C	113	73	36	8	A
	10	□	MPS0640-L10C	126	86	36	8	A
	12	●	MPS0640-L12C	139	99	36	8	A
	15	●	MPS0640-L15C	158	118	36	8	A
	20	□	MPS0640-L20C	191	151	36	8	A
	25	□	MPS0640-L25C	223	183	36	8	A
30	□	MPS0640-L30C	256	216	36	8	A	
NEW 40	□	MPS0640-L40C	321	281	36	8	A	
6.5	3	●	MPS0650S-DIN	79	34	36	8	A
	3	●	MPS0650S-DIN-C	79	34	36	8	A
	5	●	MPS0650L-DIN	91	53	36	8	A
	5	●	MPS0650L-DIN-C	91	53	36	8	A
	8	●	MPS0650-L8C	113	73	36	8	A
	10	□	MPS0650-L10C	126	86	36	8	A
	12	●	MPS0650-L12C	139	99	36	8	A
	15	●	MPS0650-L15C	158	118	36	8	A
	20	□	MPS0650-L20C	191	151	36	8	A
	25	□	MPS0650-L25C	223	183	36	8	A
30	□	MPS0650-L30C	256	216	36	8	A	
NEW 40	●	MPS0650-L40C	321	281	36	8	A	
6.6	3	●	MPS0660S-DIN	79	34	36	8	A
	3	●	MPS0660S-DIN-C	79	34	36	8	A
	5	●	MPS0660L-DIN	91	53	36	8	A
	5	●	MPS0660L-DIN-C	91	53	36	8	A
	8	●	MPS0660-L8C	118	78	36	8	A
10	□	MPS0660-L10C	132	92	36	8	A	

- : Stock Standard
- ★ : Stock Standard in Japan.
- : Non stock, produced to order only

Drill Dia. D1 (mm)	Hole Depth (l/d)	Stock VP15TF	Order Number	Dimensions (mm)				Type
				L1	L3	L9	D4	
6.6	12	●	MPS0660-L12C	146	106	36	8	A
	15	●	MPS0660-L15C	167	127	36	8	A
	20	□	MPS0660-L20C	202	162	36	8	A
	25	□	MPS0660-L25C	237	197	36	8	A
	30	□	MPS0660-L30C	272	232	36	8	A
NEW	40	□	MPS0660-L40C	341	301	36	8	A
6.7	3	●	MPS0670S-DIN	79	34	36	8	A
	3	●	MPS0670S-DIN-C	79	34	36	8	A
	5	●	MPS0670L-DIN	91	53	36	8	A
	5	●	MPS0670L-DIN-C	91	53	36	8	A
	8	●	MPS0670-L8C	118	78	36	8	A
	10	□	MPS0670-L10C	132	92	36	8	A
	12	●	MPS0670-L12C	146	106	36	8	A
	15	●	MPS0670-L15C	167	127	36	8	A
	20	□	MPS0670-L20C	202	162	36	8	A
	25	□	MPS0670-L25C	237	197	36	8	A
NEW	30	□	MPS0670-L30C	272	232	36	8	A
NEW	40	□	MPS0670-L40C	341	301	36	8	A
6.8	3	●	MPS0680S-DIN	79	34	36	8	A
	3	●	MPS0680S-DIN-C	79	34	36	8	A
	5	●	MPS0680L-DIN	91	53	36	8	A
	5	●	MPS0680L-DIN-C	91	53	36	8	A
	8	●	MPS0680-L8C	118	78	36	8	A
	10	□	MPS0680-L10C	132	92	36	8	A
	12	●	MPS0680-L12C	146	106	36	8	A
	15	●	MPS0680-L15C	167	127	36	8	A
	20	□	MPS0680-L20C	202	162	36	8	A
	25	□	MPS0680-L25C	237	197	36	8	A
NEW	30	□	MPS0680-L30C	272	232	36	8	A
NEW	40	●	MPS0680-L40C	341	301	36	8	A
6.9	3	●	MPS0690S-DIN	79	34	36	8	A
	3	●	MPS0690S-DIN-C	79	34	36	8	A
	5	●	MPS0690L-DIN	91	53	36	8	A
	5	●	MPS0690L-DIN-C	91	53	36	8	A
	8	●	MPS0690-L8C	118	78	36	8	A
	10	□	MPS0690-L10C	132	92	36	8	A
	12	●	MPS0690-L12C	146	106	36	8	A
	15	●	MPS0690-L15C	167	127	36	8	A
	20	□	MPS0690-L20C	202	162	36	8	A
	25	□	MPS0690-L25C	237	197	36	8	A
NEW	30	□	MPS0690-L30C	272	232	36	8	A
NEW	40	□	MPS0690-L40C	341	301	36	8	A
7.0	3	●	MPS0700S-DIN	79	34	36	8	A
	3	●	MPS0700S-DIN-C	79	34	36	8	A
	5	●	MPS0700L-DIN	91	53	36	8	A
	5	●	MPS0700L-DIN-C	91	53	36	8	A
	8	●	MPS0700-L8C	118	78	36	8	A
	10	□	MPS0700-L10C	132	92	36	8	A
	12	●	MPS0700-L12C	146	106	36	8	A
	15	●	MPS0700-L15C	167	127	36	8	A
	20	□	MPS0700-L20C	202	162	36	8	A
	25	□	MPS0700-L25C	237	197	36	8	A
NEW	30	□	MPS0700-L30C	272	232	36	8	A
NEW	40	●	MPS0700-L40C	341	301	36	8	A

Drill Dia. D1 (mm)	Hole Depth (l/d)	Stock VP15TF	Order Number	Dimensions (mm)				Type
				L1	L3	L9	D4	
7.1	3	●	MPS0710S-DIN	79	41	36	8	A
	3	●	MPS0710S-DIN-C	79	41	36	8	A
	5	●	MPS0710L-DIN	91	53	36	8	A
	5	●	MPS0710L-DIN-C	91	53	36	8	A
	8	●	MPS0710-L8C	124	84	36	8	A
	10	□	MPS0710-L10C	139	99	36	8	A
	12	●	MPS0710-L12C	154	114	36	8	A
	15	●	MPS0710-L15C	176	136	36	8	A
	20	□	MPS0710-L20C	214	174	36	8	A
	25	□	MPS0710-L25C	251	211	36	8	A
NEW	30	□	MPS0710-L30C	289	249	36	8	A
NEW	40	□	MPS0710-L40C	341	301	36	8	A
7.2	3	●	MPS0720S-DIN	79	41	36	8	A
	3	●	MPS0720S-DIN-C	79	41	36	8	A
	5	●	MPS0720L-DIN	91	53	36	8	A
	5	●	MPS0720L-DIN-C	91	53	36	8	A
	8	●	MPS0720-L8C	124	84	36	8	A
	10	□	MPS0720-L10C	139	99	36	8	A
	12	●	MPS0720-L12C	154	114	36	8	A
	15	●	MPS0720-L15C	176	136	36	8	A
	20	□	MPS0720-L20C	214	174	36	8	A
	25	□	MPS0720-L25C	251	211	36	8	A
NEW	30	□	MPS0720-L30C	289	249	36	8	A
NEW	40	□	MPS0720-L40C	360	321	36	8	A
7.3	3	●	MPS0730S-DIN	79	41	36	8	A
	3	●	MPS0730S-DIN-C	79	41	36	8	A
	5	●	MPS0730L-DIN	91	53	36	8	A
	5	●	MPS0730L-DIN-C	91	53	36	8	A
	8	●	MPS0730-L8C	124	84	36	8	A
	10	□	MPS0730-L10C	139	99	36	8	A
	12	●	MPS0730-L12C	154	114	36	8	A
	15	●	MPS0730-L15C	176	136	36	8	A
	20	□	MPS0730-L20C	214	174	36	8	A
	25	□	MPS0730-L25C	251	211	36	8	A
NEW	30	□	MPS0730-L30C	289	249	36	8	A
NEW	40	□	MPS0730-L40C	360	321	36	8	A
7.4	3	●	MPS0740S-DIN	79	41	36	8	A
	3	●	MPS0740S-DIN-C	79	41	36	8	A
	5	●	MPS0740L-DIN	91	53	36	8	A
	5	●	MPS0740L-DIN-C	91	53	36	8	A
	8	●	MPS0740-L8C	124	84	36	8	A
	10	□	MPS0740-L10C	139	99	36	8	A
	12	●	MPS0740-L12C	154	114	36	8	A
	15	●	MPS0740-L15C	176	136	36	8	A
	20	□	MPS0740-L20C	214	174	36	8	A
	25	□	MPS0740-L25C	251	211	36	8	A
NEW	30	□	MPS0740-L30C	289	249	36	8	A
NEW	40	□	MPS0740-L40C	360	321	36	8	A
7.5	3	●	MPS0750S-DIN	79	41	36	8	A
	3	●	MPS0750S-DIN-C	79	41	36	8	A
	5	●	MPS0750L-DIN	91	53	36	8	A
	5	●	MPS0750L-DIN-C	91	53	36	8	A
	8	●	MPS0750-L8C	124	84	36	8	A
	10	□	MPS0750-L10C	139	99	36	8	A
	12	●	MPS0750-L12C	154	114	36	8	A
	15	●	MPS0750-L15C	176	136	36	8	A

MPS DRILLS



Ø 6.6 ~ 7.5

CUTTING CONDITIONS

D078

D067

DRILLING (SOLID CARBIDE)

MPS

- From 3—40 l/d hole depth.
- MPS double margin type for accurate and reliable drilling.
- All drills with through coolant holes as standard.



D1 Tolerance	3.0≤D1≤6.0	6.0<D1≤10.0	10.0<D1≤18.0	18.0<D1≤20.0
DIN type	0.010 -0.002	0.010 -0.005	0.005 -0.013	0.005 -0.016
Others	0 -0.012	0 -0.015	0 -0.018	0 -0.021

* MPS-DIN type see table above. Other MPS drills h7 tolerance.

● Type A Double margin type

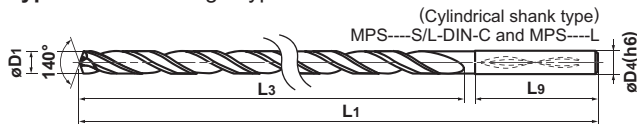

- MPS---S/L-DIN (l/d 3—5)
- MPS---S/L-DIN-C (l/d 3—5)
- MPS---L (l/d 8—40)

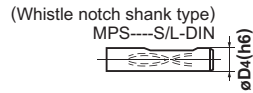

DRILLING MPS DRILLS



Ø 7.5 ~ 8.1

Drill Dia. D1 (mm)	Hole Depth (l/d)	Stock		Order Number	Dimensions (mm)				Type
		VP15TF			L1	L3	L9	D4	
7.5	20	<input type="checkbox"/>		MPS0750-L20C	214	174	36	8	A
	25	<input type="checkbox"/>		MPS0750-L25C	251	211	36	8	A
	30	<input type="checkbox"/>		MPS0750-L30C	289	249	36	8	A
	40	<input checked="" type="checkbox"/>		MPS0750-L40C	360	321	36	8	A
7.6	3	<input checked="" type="checkbox"/>		MPS0760S-DIN	79	41	36	8	A
	3	<input checked="" type="checkbox"/>		MPS0760S-DIN-C	79	41	36	8	A
	5	<input checked="" type="checkbox"/>		MPS0760L-DIN	91	53	36	8	A
	5	<input checked="" type="checkbox"/>		MPS0760L-DIN-C	91	53	36	8	A
	8	<input checked="" type="checkbox"/>		MPS0760-L8C	129	89	36	8	A
	10	<input type="checkbox"/>		MPS0760-L10C	145	105	36	8	A
	12	<input checked="" type="checkbox"/>		MPS0760-L12C	161	121	36	8	A
	15	<input checked="" type="checkbox"/>		MPS0760-L15C	185	145	36	8	A
	20	<input type="checkbox"/>		MPS0760-L20C	225	185	36	8	A
	25	<input type="checkbox"/>		MPS0760-L25C	265	225	36	8	A
	30	<input type="checkbox"/>		MPS0760-L30C	305	265	36	8	A
	40	<input type="checkbox"/>		MPS0760-L40C	379	341	36	8	A
7.7	3	<input checked="" type="checkbox"/>		MPS0770S-DIN	79	41	36	8	A
	3	<input checked="" type="checkbox"/>		MPS0770S-DIN-C	79	41	36	8	A
	5	<input checked="" type="checkbox"/>		MPS0770L-DIN	91	53	36	8	A
	5	<input checked="" type="checkbox"/>		MPS0770L-DIN-C	91	53	36	8	A
	8	<input checked="" type="checkbox"/>		MPS0770-L8C	129	89	36	8	A
	10	<input type="checkbox"/>		MPS0770-L10C	145	105	36	8	A
	12	<input checked="" type="checkbox"/>		MPS0770-L12C	161	121	36	8	A
	15	<input checked="" type="checkbox"/>		MPS0770-L15C	185	145	36	8	A
	20	<input type="checkbox"/>		MPS0770-L20C	225	185	36	8	A
	25	<input type="checkbox"/>		MPS0770-L25C	265	225	36	8	A
	30	<input type="checkbox"/>		MPS0770-L30C	305	265	36	8	A
	40	<input type="checkbox"/>		MPS0770-L40C	379	341	36	8	A
7.8	3	<input checked="" type="checkbox"/>		MPS0780S-DIN	79	41	36	8	A
	3	<input checked="" type="checkbox"/>		MPS0780S-DIN-C	79	41	36	8	A
	5	<input checked="" type="checkbox"/>		MPS0780L-DIN	91	53	36	8	A
	5	<input checked="" type="checkbox"/>		MPS0780L-DIN-C	91	53	36	8	A
	8	<input checked="" type="checkbox"/>		MPS0780-L8C	129	89	36	8	A
	10	<input type="checkbox"/>		MPS0780-L10C	145	105	36	8	A
	12	<input checked="" type="checkbox"/>		MPS0780-L12C	161	121	36	8	A
	15	<input checked="" type="checkbox"/>		MPS0780-L15C	185	145	36	8	A
	20	<input type="checkbox"/>		MPS0780-L20C	225	185	36	8	A
	25	<input type="checkbox"/>		MPS0780-L25C	265	225	36	8	A
	30	<input type="checkbox"/>		MPS0780-L30C	305	265	36	8	A
	40	<input type="checkbox"/>		MPS0780-L40C	379	341	36	8	A

Drill Dia. D1 (mm)	Hole Depth (l/d)	Stock		Order Number	Dimensions (mm)				Type
		VP15TF			L1	L3	L9	D4	
7.9	3	<input checked="" type="checkbox"/>		MPS0790S-DIN	79	41	36	8	A
	3	<input checked="" type="checkbox"/>		MPS0790S-DIN-C	79	41	36	8	A
	5	<input checked="" type="checkbox"/>		MPS0790L-DIN	91	53	36	8	A
	5	<input checked="" type="checkbox"/>		MPS0790L-DIN-C	91	53	36	8	A
	8	<input checked="" type="checkbox"/>		MPS0790-L8C	129	89	36	8	A
	10	<input type="checkbox"/>		MPS0790-L10C	145	105	36	8	A
	12	<input checked="" type="checkbox"/>		MPS0790-L12C	161	121	36	8	A
	15	<input checked="" type="checkbox"/>		MPS0790-L15C	185	145	36	8	A
	20	<input type="checkbox"/>		MPS0790-L20C	225	185	36	8	A
	25	<input type="checkbox"/>		MPS0790-L25C	265	225	36	8	A
	30	<input type="checkbox"/>		MPS0790-L30C	305	265	36	8	A
	40	<input type="checkbox"/>		MPS0790-L40C	379	341	36	8	A
8.0	3	<input checked="" type="checkbox"/>		MPS0800S-DIN	79	41	36	8	A
	3	<input checked="" type="checkbox"/>		MPS0800S-DIN-C	79	41	36	8	A
	5	<input checked="" type="checkbox"/>		MPS0800L-DIN	91	53	36	8	A
	5	<input checked="" type="checkbox"/>		MPS0800L-DIN-C	91	53	36	8	A
	8	<input checked="" type="checkbox"/>		MPS0800-L8C	129	89	36	8	A
	10	<input type="checkbox"/>		MPS0800-L10C	145	105	36	8	A
	12	<input checked="" type="checkbox"/>		MPS0800-L12C	161	121	36	8	A
	15	<input checked="" type="checkbox"/>		MPS0800-L15C	185	145	36	8	A
	20	<input type="checkbox"/>		MPS0800-L20C	225	185	36	8	A
	25	<input type="checkbox"/>		MPS0800-L25C	265	225	36	8	A
	30	<input type="checkbox"/>		MPS0800-L30C	305	265	36	8	A
	40	<input type="checkbox"/>		MPS0800-L40C	379	341	36	8	A
8.05	3	<input checked="" type="checkbox"/>		MPS0805S-DIN	88	46	40	10	A
	3	<input checked="" type="checkbox"/>		MPS0805S-DIN-C	88	46	40	10	A
	5	<input checked="" type="checkbox"/>		MPS0805L-DIN	102	60	40	10	A
	5	<input checked="" type="checkbox"/>		MPS0805L-DIN-C	102	60	40	10	A
	5	<input checked="" type="checkbox"/>		MPS0805L-DIN-C	102	60	40	10	A
8.1	3	<input checked="" type="checkbox"/>		MPS0810S-DIN	88	46	40	10	A
	3	<input checked="" type="checkbox"/>		MPS0810S-DIN-C	88	46	40	10	A
	5	<input checked="" type="checkbox"/>		MPS0810L-DIN	102	60	40	10	A
	5	<input checked="" type="checkbox"/>		MPS0810L-DIN-C	102	60	40	10	A
	5	<input checked="" type="checkbox"/>		MPS0810L-DIN-C	102	60	40	10	A
	8	<input checked="" type="checkbox"/>		MPS0810-L8C	139	95	40	10	A
	10	<input type="checkbox"/>		MPS0810-L10C	156	112	40	10	A
	12	<input checked="" type="checkbox"/>		MPS0810-L12C	173	129	40	10	A
	15	<input checked="" type="checkbox"/>		MPS0810-L15C	198	154	40	10	A
	20	<input type="checkbox"/>		MPS0810-L20C	241	197	40	10	A
	25	<input type="checkbox"/>		MPS0810-L25C	283	239	40	10	A
	30	<input type="checkbox"/>		MPS0810-L30C	326	282	40	10	A
40	<input type="checkbox"/>		MPS0810-L40C	411	366	36	10	A	

- : Stock Standard
- ★ : Stock Standard in Japan.
- : Non stock, produced to order only

Drill Dia. D1 (mm)	Hole Depth (l/d)	Stock		Order Number	Dimensions (mm)				Type
		VP15TF			L1	L3	L9	D4	
8.2	3	●		MPS0820S-DIN	88	46	40	10	A
	3	●		MPS0820S-DIN-C	88	46	40	10	A
	5	●		MPS0820L-DIN	102	60	40	10	A
	5	●		MPS0820L-DIN-C	102	60	40	10	A
	8	●		MPS0820-L8C	139	95	40	10	A
	10	□		MPS0820-L10C	156	112	40	10	A
	12	●		MPS0820-L12C	173	129	40	10	A
	15	●		MPS0820-L15C	198	154	40	10	A
	20	□		MPS0820-L20C	241	197	40	10	A
	25	□		MPS0820-L25C	283	239	40	10	A
NEW	30	□		MPS0820-L30C	326	282	40	10	A
	40	□		MPS0820-L40C	411	366	40	10	A
8.3	3	●		MPS0830S-DIN	88	46	40	10	A
	3	●		MPS0830S-DIN-C	88	46	40	10	A
	5	●		MPS0830L-DIN	102	60	40	10	A
	5	●		MPS0830L-DIN-C	102	60	40	10	A
	8	●		MPS0830-L8C	139	95	40	10	A
	10	□		MPS0830-L10C	156	112	40	10	A
	12	●		MPS0830-L12C	173	129	40	10	A
	15	●		MPS0830-L15C	198	154	40	10	A
	20	□		MPS0830-L20C	241	197	40	10	A
	25	□		MPS0830-L25C	283	239	40	10	A
NEW	30	□		MPS0830-L30C	326	282	40	10	A
	40	□		MPS0830-L40C	412	367	40	10	A
8.4	3	●		MPS0840S-DIN	88	46	40	10	A
	3	●		MPS0840S-DIN-C	88	46	40	10	A
	5	●		MPS0840L-DIN	102	60	40	10	A
	5	●		MPS0840L-DIN-C	102	60	40	10	A
	8	●		MPS0840-L8C	139	95	40	10	A
	10	□		MPS0840-L10C	156	112	40	10	A
	12	●		MPS0840-L12C	173	129	40	10	A
	15	●		MPS0840-L15C	198	154	40	10	A
	20	□		MPS0840-L20C	241	197	40	10	A
	25	□		MPS0840-L25C	283	239	40	10	A
NEW	30	□		MPS0840-L30C	326	282	40	10	A
	40	□		MPS0840-L40C	412	367	40	10	A
8.5	3	●		MPS0850S-DIN	88	46	40	10	A
	3	●		MPS0850S-DIN-C	88	46	40	10	A
	5	●		MPS0850L-DIN	102	60	40	10	A
	5	●		MPS0850L-DIN-C	102	60	40	10	A
	8	●		MPS0850-L8C	139	95	40	10	A
	10	□		MPS0850-L10C	156	112	40	10	A
	12	●		MPS0850-L12C	173	129	40	10	A
	15	●		MPS0850-L15C	198	154	40	10	A
	20	□		MPS0850-L20C	241	197	40	10	A
	25	□		MPS0850-L25C	283	239	40	10	A
NEW	30	□		MPS0850-L30C	326	282	40	10	A
	40	●		MPS0850-L40C	412	367	40	10	A
8.6	3	●		MPS0860S-DIN	88	46	40	10	A
	3	●		MPS0860S-DIN-C	88	46	40	10	A
	5	●		MPS0860L-DIN	102	60	40	10	A
	5	●		MPS0860L-DIN-C	102	60	40	10	A
	8	●		MPS0860-L8C	144	100	40	10	A
	10	□		MPS0860-L10C	162	118	40	10	A
	12	●		MPS0860-L12C	180	136	40	10	A
	15	●		MPS0860-L15C	207	163	40	10	A

Drill Dia. D1 (mm)	Hole Depth (l/d)	Stock		Order Number	Dimensions (mm)				Type
		VP15TF			L1	L3	L9	D4	
8.6	20	□		MPS0860-L20C	252	208	40	10	A
	25	□		MPS0860-L25C	297	253	40	10	A
	30	□		MPS0860-L30C	342	298	40	10	A
	NEW	40	□	MPS0860-L40C	436	392	40	10	A
	8.7	3	●		MPS0870S-DIN	88	46	40	10
3		●		MPS0870S-DIN-C	88	46	40	10	A
5		●		MPS0870L-DIN	102	60	40	10	A
5		●		MPS0870L-DIN-C	102	60	40	10	A
8		●		MPS0870-L8C	144	100	40	10	A
10		□		MPS0870-L10C	162	118	40	10	A
12		●		MPS0870-L12C	180	136	40	10	A
15		●		MPS0870-L15C	207	163	40	10	A
20		□		MPS0870-L20C	252	208	40	10	A
25		□		MPS0870-L25C	297	253	40	10	A
NEW	30	□		MPS0870-L30C	342	298	40	10	A
	40	□		MPS0870-L40C	436	392	40	10	A
8.8	3	●		MPS0880S-DIN	88	46	40	10	A
	3	●		MPS0880S-DIN-C	88	46	40	10	A
	5	●		MPS0880L-DIN	102	60	40	10	A
	5	●		MPS0880L-DIN-C	102	60	40	10	A
	8	●		MPS0880-L8C	144	100	40	10	A
	10	□		MPS0880-L10C	162	118	40	10	A
	12	●		MPS0880-L12C	180	136	40	10	A
	15	●		MPS0880-L15C	207	163	40	10	A
	20	□		MPS0880-L20C	252	208	40	10	A
	25	□		MPS0880-L25C	297	253	40	10	A
NEW	30	□		MPS0880-L30C	342	298	40	10	A
	40	□		MPS0880-L40C	436	392	40	10	A
8.9	3	●		MPS0890S-DIN	88	46	40	10	A
	3	●		MPS0890S-DIN-C	88	46	40	10	A
	5	●		MPS0890L-DIN	102	60	40	10	A
	5	●		MPS0890L-DIN-C	102	60	40	10	A
	8	●		MPS0890-L8C	144	100	40	10	A
	10	□		MPS0890-L10C	162	118	40	10	A
	12	●		MPS0890-L12C	180	136	40	10	A
	15	●		MPS0890-L15C	207	163	40	10	A
	20	□		MPS0890-L20C	252	208	40	10	A
	25	□		MPS0890-L25C	297	253	40	10	A
NEW	30	□		MPS0890-L30C	342	298	40	10	A
	40	□		MPS0890-L40C	436	392	40	10	A
9.0	3	●		MPS0900S-DIN	88	46	40	10	A
	3	●		MPS0900S-DIN-C	88	46	40	10	A
	5	●		MPS0900L-DIN	102	60	40	10	A
	5	●		MPS0900L-DIN-C	102	60	40	10	A
	8	●		MPS0900-L8C	144	100	40	10	A
	10	□		MPS0900-L10C	162	118	40	10	A
	12	●		MPS0900-L12C	180	136	40	10	A
	15	●		MPS0900-L15C	207	163	40	10	A
	20	□		MPS0900-L20C	252	208	40	10	A
	25	□		MPS0900-L25C	297	253	40	10	A
NEW	30	□		MPS0900-L30C	342	298	40	10	A
	40	●		MPS0900-L40C	436	392	40	10	A
9.1	3	●		MPS0910S-DIN	89	47	40	10	A
	3	●		MPS0910S-DIN-C	89	47	40	10	A
	5	●		MPS0910L-DIN	103	62	40	10	A
	5	●		MPS0910L-DIN-C	103	62	40	10	A

MPS DRILLS



Ø 8.2 ~ 9.1

CUTTING CONDITIONS

D078

D069

DRILLING (SOLID CARBIDE)

MPS

- From 3—40 l/d hole depth.
- MPS double margin type for accurate and reliable drilling.
- All drills with through coolant holes as standard.



D1 Tolerance	3.0≤D1≤6.0	6.0<D1≤10.0	10.0<D1≤18.0	18.0<D1≤20.0
DIN type	0.010 -0.002	0.010 -0.005	0.005 -0.013	0.005 -0.016
Others	0 -0.012	0 -0.015	0 -0.018	0 -0.021

* MPS-DIN type see table above. Other MPS drills h7 tolerance.

● Type A Double margin type

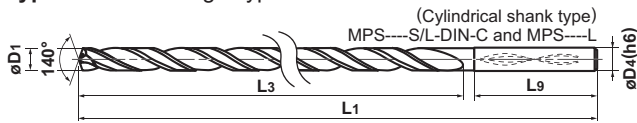

- MPS---S/L-DIN (l/d 3—5)
- MPS---S/L-DIN-C (l/d 3—5)
- MPS---L (l/d 8—40)

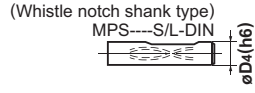

Drill Dia. D1 (mm)	Hole Depth (l/d)	Stock		Order Number	Dimensions (mm)				Type
		VP15TF			L1	L3	L9	D4	
9.1	8	●		MPS0910-L8C	151	107	40	10	A
	10	□		MPS0910-L10C	170	126	40	10	A
	12	●		MPS0910-L12C	189	145	40	10	A
	15	●		MPS0910-L15C	217	173	40	10	A
	20	□		MPS0910-L20C	265	221	40	10	A
	25	□		MPS0910-L25C	312	268	40	10	A
	30	□		MPS0910-L30C	360	316	40	10	A
9.2	3	●		MPS0920S-DIN	89	47	40	10	A
	3	●		MPS0920S-DIN-C	89	47	40	10	A
	5	●		MPS0920L-DIN	103	62	40	10	A
	5	●		MPS0920L-DIN-C	103	62	40	10	A
	8	●		MPS0920-L8C	151	107	40	10	A
	10	□		MPS0920-L10C	170	126	40	10	A
	12	●		MPS0920-L12C	189	145	40	10	A
	15	●		MPS0920-L15C	217	173	40	10	A
	20	□		MPS0920-L20C	265	221	40	10	A
25	□		MPS0920-L25C	312	268	40	10	A	
30	□		MPS0920-L30C	360	316	40	10	A	
9.3	3	●		MPS0930S-DIN	89	47	40	10	A
	3	●		MPS0930S-DIN-C	89	47	40	10	A
	5	●		MPS0930L-DIN	103	62	40	10	A
	5	●		MPS0930L-DIN-C	103	62	40	10	A
	8	●		MPS0930-L8C	151	107	40	10	A
	10	□		MPS0930-L10C	170	126	40	10	A
	12	●		MPS0930-L12C	189	145	40	10	A
	15	●		MPS0930-L15C	217	173	40	10	A
	20	□		MPS0930-L20C	265	221	40	10	A
25	□		MPS0930-L25C	312	268	40	10	A	
30	□		MPS0930-L30C	360	316	40	10	A	
9.4	3	●		MPS0940S-DIN	89	47	40	10	A
	3	●		MPS0940S-DIN-C	89	47	40	10	A
	5	●		MPS0940L-DIN	103	62	40	10	A
	5	●		MPS0940L-DIN-C	103	62	40	10	A
	8	●		MPS0940-L8C	151	107	40	10	A
	10	□		MPS0940-L10C	170	126	40	10	A
	12	●		MPS0940-L12C	189	145	40	10	A
	15	●		MPS0940-L15C	217	173	40	10	A
	20	□		MPS0940-L20C	265	221	40	10	A
	25	□		MPS0940-L25C	312	268	40	10	A
30	□		MPS0940-L30C	360	316	40	10	A	

Drill Dia. D1 (mm)	Hole Depth (l/d)	Stock		Order Number	Dimensions (mm)				Type
		VP15TF			L1	L3	L9	D4	
9.5	3	●		MPS0950S-DIN	89	47	40	10	A
	3	●		MPS0950S-DIN-C	89	47	40	10	A
	5	●		MPS0950L-DIN	103	62	40	10	A
	5	●		MPS0950L-DIN-C	103	62	40	10	A
	8	●		MPS0950-L8C	151	107	40	10	A
	10	□		MPS0950-L10C	170	126	40	10	A
	12	●		MPS0950-L12C	189	145	40	10	A
	15	●		MPS0950-L15C	217	173	40	10	A
	20	□		MPS0950-L20C	265	221	40	10	A
	25	□		MPS0950-L25C	312	268	40	10	A
9.6	30	□		MPS0950-L30C	360	316	40	10	A
	3	●		MPS0960S-DIN	89	47	40	10	A
	3	●		MPS0960S-DIN-C	89	47	40	10	A
	5	●		MPS0960L-DIN	103	62	40	10	A
	5	●		MPS0960L-DIN-C	103	62	40	10	A
	8	●		MPS0960-L8C	156	112	40	10	A
	10	□		MPS0960-L10C	176	132	40	10	A
	12	●		MPS0960-L12C	196	152	40	10	A
	15	●		MPS0960-L15C	226	182	40	10	A
	20	□		MPS0960-L20C	276	232	40	10	A
9.7	25	□		MPS0960-L25C	326	282	40	10	A
	30	□		MPS0960-L30C	376	332	40	10	A
	3	●		MPS0970S-DIN	89	47	40	10	A
	3	●		MPS0970S-DIN-C	89	47	40	10	A
	5	●		MPS0970L-DIN	103	62	40	10	A
	5	●		MPS0970L-DIN-C	103	62	40	10	A
	8	●		MPS0970-L8C	156	112	40	10	A
	10	□		MPS0970-L10C	176	132	40	10	A
	12	●		MPS0970-L12C	196	152	40	10	A
	15	●		MPS0970-L15C	226	182	40	10	A
9.8	20	□		MPS0970-L20C	276	232	40	10	A
	25	□		MPS0970-L25C	326	282	40	10	A
	30	□		MPS0970-L30C	376	332	40	10	A
	3	●		MPS0980S-DIN	89	47	40	10	A
	3	●		MPS0980S-DIN-C	89	47	40	10	A
	5	●		MPS0980L-DIN	103	62	40	10	A
	5	●		MPS0980L-DIN-C	103	62	40	10	A
	8	●		MPS0980-L8C	156	112	40	10	A
	10	□		MPS0980-L10C	176	132	40	10	A
	12	●		MPS0980-L12C	196	152	40	10	A
15	●		MPS0980-L15C	226	182	40	10	A	
20	□		MPS0980-L20C	276	232	40	10	A	

- : Stock Standard
- ★ : Stock Standard in Japan.
- : Non stock, produced to order only

Drill Dia. D1 (mm)	Hole Depth (l/d)	Stock		Order Number	Dimensions (mm)				Type	
		VP15TF			L1	L3	L9	D4		
9.8	25	<input type="checkbox"/>		MPS0980-L25C	326	282	40	10	A	
	30	<input type="checkbox"/>		MPS0980-L30C	376	332	40	10	A	
9.9	3	<input checked="" type="radio"/>		MPS0990S-DIN	89	47	40	10	A	
	3	<input checked="" type="radio"/>		MPS0990S-DIN-C	89	47	40	10	A	
	5	<input checked="" type="radio"/>		MPS0990L-DIN	103	62	40	10	A	
	5	<input checked="" type="radio"/>		MPS0990L-DIN-C	103	62	40	10	A	
	8	<input checked="" type="radio"/>		MPS0990-L8C	156	112	40	10	A	
	10	<input type="checkbox"/>		MPS0990-L10C	176	132	40	10	A	
	12	<input checked="" type="radio"/>		MPS0990-L12C	196	152	40	10	A	
	15	<input checked="" type="radio"/>		MPS0990-L15C	226	182	40	10	A	
	20	<input type="checkbox"/>		MPS0990-L20C	276	232	40	10	A	
	25	<input type="checkbox"/>		MPS0990-L25C	326	282	40	10	A	
10.0	30	<input type="checkbox"/>		MPS0990-L30C	376	332	40	10	A	
	3	<input checked="" type="radio"/>		MPS1000S-DIN	89	47	40	10	A	
	3	<input checked="" type="radio"/>		MPS1000S-DIN-C	89	47	40	10	A	
	5	<input checked="" type="radio"/>		MPS1000L-DIN	103	62	40	10	A	
	5	<input checked="" type="radio"/>		MPS1000L-DIN-C	103	62	40	10	A	
	8	<input checked="" type="radio"/>		MPS1000-L8C	156	112	40	10	A	
	10	<input type="checkbox"/>		MPS1000-L10C	176	132	40	10	A	
	12	<input checked="" type="radio"/>		MPS1000-L12C	196	152	40	10	A	
	15	<input checked="" type="radio"/>		MPS1000-L15C	226	182	40	10	A	
	20	<input type="checkbox"/>		MPS1000-L20C	276	232	40	10	A	
10.05	25	<input type="checkbox"/>		MPS1000-L25C	326	282	40	10	A	
	30	<input type="checkbox"/>		MPS1000-L30C	376	332	40	10	A	
	3	<input checked="" type="radio"/>		MPS1005S-DIN	102	55	45	12	A	
	3	<input checked="" type="radio"/>		MPS1005S-DIN-C	102	55	45	12	A	
	5	<input checked="" type="radio"/>		MPS1005L-DIN	118	71	45	12	A	
	5	<input checked="" type="radio"/>		MPS1005L-DIN-C	118	71	45	12	A	
	10.1	3	<input checked="" type="radio"/>		MPS1010S-DIN	102	55	45	12	A
		3	<input checked="" type="radio"/>		MPS1010S-DIN-C	102	55	45	12	A
5		<input checked="" type="radio"/>		MPS1010L-DIN	118	71	45	12	A	
5		<input checked="" type="radio"/>		MPS1010L-DIN-C	118	71	45	12	A	
8		<input checked="" type="radio"/>		MPS1010-L8C	167	118	45	12	A	
10		<input type="checkbox"/>		MPS1010-L10C	188	139	45	12	A	
12		<input checked="" type="radio"/>		MPS1010-L12C	209	160	45	12	A	
15		<input checked="" type="radio"/>		MPS1010-L15C	240	191	45	12	A	
20		<input type="checkbox"/>		MPS1010-L20C	293	244	45	12	A	
25		<input type="checkbox"/>		MPS1010-L25C	345	296	45	12	A	
10.2	3	<input checked="" type="radio"/>		MPS1020S-DIN	102	55	45	12	A	
	3	<input checked="" type="radio"/>		MPS1020S-DIN-C	102	55	45	12	A	
	5	<input checked="" type="radio"/>		MPS1020L-DIN	118	71	45	12	A	
	5	<input checked="" type="radio"/>		MPS1020L-DIN-C	118	71	45	12	A	
	8	<input checked="" type="radio"/>		MPS1020-L8C	167	118	45	12	A	
	10	<input type="checkbox"/>		MPS1020-L10C	188	139	45	12	A	
	12	<input checked="" type="radio"/>		MPS1020-L12C	209	160	45	12	A	
10.3	15	<input checked="" type="radio"/>		MPS1020-L15C	240	191	45	12	A	
	20	<input type="checkbox"/>		MPS1020-L20C	293	244	45	12	A	
	25	<input type="checkbox"/>		MPS1020-L25C	345	296	45	12	A	
	3	<input checked="" type="radio"/>		MPS1030S-DIN	102	55	45	12	A	
	3	<input checked="" type="radio"/>		MPS1030S-DIN-C	102	55	45	12	A	
	5	<input checked="" type="radio"/>		MPS1030L-DIN	118	71	45	12	A	
	5	<input checked="" type="radio"/>		MPS1030L-DIN-C	118	71	45	12	A	
10.3	8	<input checked="" type="radio"/>		MPS1030-L8C	167	118	45	12	A	
	10	<input type="checkbox"/>		MPS1030-L10C	188	139	45	12	A	
	12	<input checked="" type="radio"/>		MPS1030-L12C	209	160	45	12	A	
	15	<input checked="" type="radio"/>		MPS1030-L15C	240	191	45	12	A	

Drill Dia. D1 (mm)	Hole Depth (l/d)	Stock		Order Number	Dimensions (mm)				Type	
		VP15TF			L1	L3	L9	D4		
10.3	20	<input type="checkbox"/>		MPS1030-L20C	293	244	45	12	A	
	25	<input type="checkbox"/>		MPS1030-L25C	345	296	45	12	A	
10.4	3	<input checked="" type="radio"/>		MPS1040S-DIN	102	55	45	12	A	
	3	<input checked="" type="radio"/>		MPS1040S-DIN-C	102	55	45	12	A	
	5	<input checked="" type="radio"/>		MPS1040L-DIN	118	71	45	12	A	
	5	<input checked="" type="radio"/>		MPS1040L-DIN-C	118	71	45	12	A	
	8	<input checked="" type="radio"/>		MPS1040-L8C	167	118	45	12	A	
	10	<input type="checkbox"/>		MPS1040-L10C	188	139	45	12	A	
	12	<input checked="" type="radio"/>		MPS1040-L12C	209	160	45	12	A	
	15	<input checked="" type="radio"/>		MPS1040-L15C	240	191	45	12	A	
	20	<input type="checkbox"/>		MPS1040-L20C	293	244	45	12	A	
	25	<input type="checkbox"/>		MPS1040-L25C	345	296	45	12	A	
10.5	3	<input checked="" type="radio"/>		MPS1050S-DIN	102	55	45	12	A	
	3	<input checked="" type="radio"/>		MPS1050S-DIN-C	102	55	45	12	A	
	5	<input checked="" type="radio"/>		MPS1050L-DIN	118	71	45	12	A	
	5	<input checked="" type="radio"/>		MPS1050L-DIN-C	118	71	45	12	A	
	8	<input type="checkbox"/>		MPS1050-L8C	167	118	45	12	A	
	10	<input checked="" type="radio"/>		MPS1050-L10C	188	139	45	12	A	
	12	<input checked="" type="radio"/>		MPS1050-L12C	209	160	45	12	A	
	15	<input type="checkbox"/>		MPS1050-L15C	240	191	45	12	A	
	20	<input type="checkbox"/>		MPS1050-L20C	293	244	45	12	A	
10.6	25	<input checked="" type="radio"/>		MPS1050-L25C	345	296	45	12	A	
	3	<input checked="" type="radio"/>		MPS1060S-DIN	102	55	45	12	A	
	3	<input checked="" type="radio"/>		MPS1060S-DIN-C	102	55	45	12	A	
	5	<input checked="" type="radio"/>		MPS1060L-DIN	118	71	45	12	A	
	5	<input checked="" type="radio"/>		MPS1060L-DIN-C	118	71	45	12	A	
	8	<input checked="" type="radio"/>		MPS1060-L8C	172	123	45	12	A	
	10	<input type="checkbox"/>		MPS1060-L10C	194	145	45	12	A	
	12	<input checked="" type="radio"/>		MPS1060-L12C	216	167	45	12	A	
	15	<input checked="" type="radio"/>		MPS1060-L15C	249	200	45	12	A	
10.7	20	<input type="checkbox"/>		MPS1060-L20C	304	255	45	12	A	
	25	<input type="checkbox"/>		MPS1060-L25C	359	310	45	12	A	
	3	<input checked="" type="radio"/>		MPS1070S-DIN	102	55	45	12	A	
	3	<input checked="" type="radio"/>		MPS1070S-DIN-C	102	55	45	12	A	
	5	<input checked="" type="radio"/>		MPS1070L-DIN	118	71	45	12	A	
	5	<input checked="" type="radio"/>		MPS1070L-DIN-C	118	71	45	12	A	
	8	<input checked="" type="radio"/>		MPS1070-L8C	172	123	45	12	A	
10.8	10	<input type="checkbox"/>		MPS1070-L10C	194	145	45	12	A	
	12	<input checked="" type="radio"/>		MPS1070-L12C	216	167	45	12	A	
	15	<input checked="" type="radio"/>		MPS1070-L15C	249	200	45	12	A	
	20	<input type="checkbox"/>		MPS1070-L20C	304	255	45	12	A	
	25	<input type="checkbox"/>		MPS1070-L25C	359	310	45	12	A	
	10.9	3	<input checked="" type="radio"/>		MPS1080S-DIN	102	55	45	12	A
		3	<input checked="" type="radio"/>		MPS1080S-DIN-C	102	55	45	12	A
5		<input checked="" type="radio"/>		MPS1080L-DIN	118	71	45	12	A	
5		<input checked="" type="radio"/>		MPS1080L-DIN-C	118	71	45	12	A	
8		<input checked="" type="radio"/>		MPS1080-L8C	172	123	45	12	A	
10		<input type="checkbox"/>		MPS1080-L10C	194	145	45	12	A	
12		<input checked="" type="radio"/>		MPS1080-L12C	216	167	45	12	A	
15		<input checked="" type="radio"/>		MPS1080-L15C	249	200	45	12	A	
20		<input type="checkbox"/>		MPS1080-L20C	304	255	45	12	A	
25		<input type="checkbox"/>		MPS1080-L25C	359	310	45	12	A	
10.9	3	<input checked="" type="radio"/>		MPS1090S-DIN	102	55	45	12	A	
	3	<input checked="" type="radio"/>		MPS1090S-DIN-C	102	55	45	12	A	
	5	<input checked="" type="radio"/>		MPS1090L-DIN	118	71	45	12	A	
	5	<input checked="" type="radio"/>		MPS1090L-DIN-C	118	71	45	12	A	

MPS DRILLS



Ø 9.8 ~ 10.9

DRILLING (SOLID CARBIDE)

MPS

- From 3—40 l/d hole depth.
- MPS double margin type for accurate and reliable drilling.
- All drills with through coolant holes as standard.



D1 Tolerance	3.0≤D1≤6.0	6.0<D1≤10.0	10.0<D1≤18.0	18.0<D1≤20.0
DIN type	0.010 -0.002	0.010 -0.005	0.005 -0.013	0.005 -0.016
Others	0 -0.012	0 -0.015	0 -0.018	0 -0.021

* MPS-DIN type see table above. Other MPS drills h7 tolerance.

● Type A Double margin type

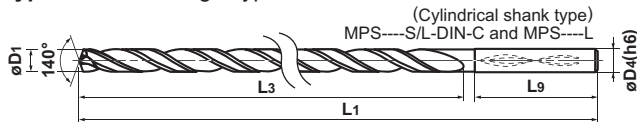

- MPS---S/L-DIN (l/d 3—5)
- MPS---S/L-DIN-C (l/d 3—5)
- MPS---L (l/d 8—40)

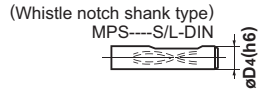

DRILLING MPS DRILLS

DRILLING
Ø 10.9 ~ 11.7

Drill Dia. D1 (mm)	Hole Depth (l/d)	Stock		Order Number	Dimensions (mm)				Type
		VP15TF			L1	L3	L9	D4	
10.9	8	●		MPS1090-L8C	172	123	45	12	A
	10	□		MPS1090-L10C	194	145	45	12	A
	12	●		MPS1090-L12C	216	167	45	12	A
	15	●		MPS1090-L15C	249	200	45	12	A
	20	□		MPS1090-L20C	304	255	45	12	A
	25	□		MPS1090-L25C	359	310	45	12	A
11.0	3	●		MPS1100S-DIN	102	55	45	12	A
	3	●		MPS1100S-DIN-C	102	55	45	12	A
	5	●		MPS1100L-DIN	118	71	45	12	A
	5	●		MPS1100L-DIN-C	118	71	45	12	A
	8	●		MPS1100-L8C	172	123	45	12	A
	10	□		MPS1100-L10C	194	145	45	12	A
	12	●		MPS1100-L12C	216	167	45	12	A
	15	●		MPS1100-L15C	249	200	45	12	A
	20	□		MPS1100-L20C	304	255	45	12	A
	25	□		MPS1100-L25C	359	310	45	12	A
11.1	3	●		MPS1110S-DIN	102	55	45	12	A
	3	●		MPS1110S-DIN-C	102	55	45	12	A
	5	●		MPS1110L-DIN	118	71	45	12	A
	5	●		MPS1110L-DIN-C	118	71	45	12	A
	8	●		MPS1110-L8C	178	129	45	12	A
	10	□		MPS1110-L10C	201	152	45	12	A
	12	●		MPS1110-L12C	224	175	45	12	A
	15	●		MPS1110-L15C	258	209	45	12	A
	20	□		MPS1110-L20C	316	267	45	12	A
	25	□		MPS1110-L25C	373	324	45	12	A
11.2	3	●		MPS1120S-DIN	102	55	45	12	A
	3	●		MPS1120S-DIN-C	102	55	45	12	A
	5	●		MPS1120L-DIN	118	71	45	12	A
	5	●		MPS1120L-DIN-C	118	71	45	12	A
	8	●		MPS1120-L8C	178	129	45	12	A
	10	□		MPS1120-L10C	201	152	45	12	A
	12	●		MPS1120-L12C	224	175	45	12	A
	15	●		MPS1120-L15C	258	209	45	12	A
	20	□		MPS1120-L20C	316	267	45	12	A
	25	□		MPS1120-L25C	373	324	45	12	A
11.3		●		MPS1130S-DIN	102	55	45	12	A
		●		MPS1130S-DIN-C	102	55	45	12	A
		●		MPS1130L-DIN	118	71	45	12	A
		●		MPS1130L-DIN-C	118	71	45	12	A
		●		MPS1130-L8C	178	129	45	12	A
		□		MPS1130-L10C	201	152	45	12	A

Drill Dia. D1 (mm)	Hole Depth (l/d)	Stock		Order Number	Dimensions (mm)				Type
		VP15TF			L1	L3	L9	D4	
11.3	12	●		MPS1130-L12C	224	175	45	12	A
	15	●		MPS1130-L15C	258	209	45	12	A
	20	□		MPS1130-L20C	316	267	45	12	A
	25	□		MPS1130-L25C	373	324	45	12	A
	11.4	3	●		MPS1140S-DIN	102	55	45	12
3		●		MPS1140S-DIN-C	102	55	45	12	A
5		●		MPS1140L-DIN	118	71	45	12	A
5		●		MPS1140L-DIN-C	118	71	45	12	A
8		●		MPS1140-L8C	178	129	45	12	A
10		□		MPS1140-L10C	201	152	45	12	A
12		●		MPS1140-L12C	224	175	45	12	A
15		●		MPS1140-L15C	258	209	45	12	A
20		□		MPS1140-L20C	316	267	45	12	A
25		□		MPS1140-L25C	373	324	45	12	A
11.5	3	●		MPS1150S-DIN	102	55	45	12	A
	3	●		MPS1150S-DIN-C	102	55	45	12	A
	5	●		MPS1150L-DIN	118	71	45	12	A
	5	●		MPS1150L-DIN-C	118	71	45	12	A
	8	●		MPS1150-L8C	178	129	45	12	A
	10	□		MPS1150-L10C	201	152	45	12	A
	12	●		MPS1150-L12C	224	175	45	12	A
	15	●		MPS1150-L15C	258	209	45	12	A
	20	□		MPS1150-L20C	316	267	45	12	A
	25	□		MPS1150-L25C	373	324	45	12	A
11.6	3	●		MPS1160S-DIN	102	55	45	12	A
	3	●		MPS1160S-DIN-C	102	55	45	12	A
	5	●		MPS1160L-DIN	118	71	45	12	A
	5	●		MPS1160L-DIN-C	118	71	45	12	A
	8	●		MPS1160-L8C	183	134	45	12	A
	10	□		MPS1160-L10C	207	158	45	12	A
	12	●		MPS1160-L12C	231	182	45	12	A
	15	●		MPS1160-L15C	267	218	45	12	A
	20	□		MPS1160-L20C	327	278	45	12	A
	25	□		MPS1160-L25C	387	338	45	12	A
11.7	3	●		MPS1170S-DIN	102	55	45	12	A
	3	●		MPS1170S-DIN-C	102	55	45	12	A
	5	●		MPS1170L-DIN	118	71	45	12	A
	5	●		MPS1170L-DIN-C	118	71	45	12	A
	8	●		MPS1170-L8C	183	134	45	12	A
	10	□		MPS1170-L10C	207	158	45	12	A
	12	●		MPS1170-L12C	231	182	45	12	A
15	●		MPS1170-L15C	267	218	45	12	A	

- : Stock Standard.
- ★ : Stock Standard in Japan.
- : Non stock, produced to order only.

Drill Dia. D1 (mm)	Hole Depth (mm)	Stock		Order Number	Dimensions (mm)				Type
		VP15TF			L1	L3	L9	D4	
11.7	20	<input type="checkbox"/>		MPS1170-L20C	327	278	45	12	A
	25	<input type="checkbox"/>		MPS1170-L25C	387	338	45	12	A
11.8	3	<input checked="" type="checkbox"/>		MPS1180S-DIN	102	55	45	12	A
	3	<input checked="" type="checkbox"/>		MPS1180S-DIN-C	102	55	45	12	A
	5	<input checked="" type="checkbox"/>		MPS1180L-DIN	118	71	45	12	A
	5	<input checked="" type="checkbox"/>		MPS1180L-DIN-C	118	71	45	12	A
	8	<input checked="" type="checkbox"/>		MPS1180-L8C	183	134	45	12	A
	10	<input type="checkbox"/>		MPS1180-L10C	207	158	45	12	A
	12	<input checked="" type="checkbox"/>		MPS1180-L12C	231	182	45	12	A
	15	<input checked="" type="checkbox"/>		MPS1180-L15C	267	218	45	12	A
	20	<input type="checkbox"/>		MPS1180-L20C	327	278	45	12	A
	25	<input type="checkbox"/>		MPS1180-L25C	387	338	45	12	A
11.9	3	<input checked="" type="checkbox"/>		MPS1190S-DIN	102	55	45	12	A
	3	<input checked="" type="checkbox"/>		MPS1190S-DIN-C	102	55	45	12	A
	5	<input checked="" type="checkbox"/>		MPS1190L-DIN	118	71	45	12	A
	5	<input checked="" type="checkbox"/>		MPS1190L-DIN-C	118	71	45	12	A
	8	<input checked="" type="checkbox"/>		MPS1190-L8C	183	134	45	12	A
	10	<input type="checkbox"/>		MPS1190-L10C	207	158	45	12	A
	12	<input checked="" type="checkbox"/>		MPS1190-L12C	231	182	45	12	A
	15	<input checked="" type="checkbox"/>		MPS1190-L15C	267	218	45	12	A
	20	<input type="checkbox"/>		MPS1190-L20C	327	278	45	12	A
	25	<input type="checkbox"/>		MPS1190-L25C	387	338	45	12	A
12.0	3	<input checked="" type="checkbox"/>		MPS1200S-DIN	102	55	45	12	A
	3	<input checked="" type="checkbox"/>		MPS1200S-DIN-C	102	55	45	12	A
	5	<input checked="" type="checkbox"/>		MPS1200L-DIN	118	71	45	12	A
	5	<input checked="" type="checkbox"/>		MPS1200L-DIN-C	118	71	45	12	A
	8	<input checked="" type="checkbox"/>		MPS1200-L8C	183	134	45	12	A
	10	<input type="checkbox"/>		MPS1200-L10C	207	158	45	12	A
	12	<input checked="" type="checkbox"/>		MPS1200-L12C	231	182	45	12	A
	15	<input checked="" type="checkbox"/>		MPS1200-L15C	267	218	45	12	A
	20	<input type="checkbox"/>		MPS1200-L20C	327	278	45	12	A
	25	<input type="checkbox"/>		MPS1200-L25C	387	338	45	12	A
12.05	3	<input checked="" type="checkbox"/>		MPS1205S-DIN	107	60	45	14	A
	3	<input checked="" type="checkbox"/>		MPS1205S-DIN-C	107	60	45	14	A
	5	<input checked="" type="checkbox"/>		MPS1205L-DIN	124	77	45	14	A
	5	<input checked="" type="checkbox"/>		MPS1205L-DIN-C	124	77	45	14	A
12.1	3	<input checked="" type="checkbox"/>		MPS1210S-DIN	107	60	45	14	A
	3	<input checked="" type="checkbox"/>		MPS1210S-DIN-C	107	60	45	14	A
	5	<input checked="" type="checkbox"/>		MPS1210L-DIN	124	77	45	14	A
	5	<input checked="" type="checkbox"/>		MPS1210L-DIN-C	124	77	45	14	A
	8	<input checked="" type="checkbox"/>		MPS1210-L8C	189	140	45	14	A
	10	<input type="checkbox"/>		MPS1210-L10C	214	165	45	14	A
	12	<input checked="" type="checkbox"/>		MPS1210-L12C	239	190	45	14	A
	15	<input checked="" type="checkbox"/>		MPS1210-L15C	276	227	45	14	A
12.2	20	<input type="checkbox"/>		MPS1210-L20C	339	290	45	14	A
	3	<input checked="" type="checkbox"/>		MPS1220S-DIN	107	60	45	14	A
	3	<input checked="" type="checkbox"/>		MPS1220S-DIN-C	107	60	45	14	A
	5	<input checked="" type="checkbox"/>		MPS1220L-DIN	124	77	45	14	A
	5	<input checked="" type="checkbox"/>		MPS1220L-DIN-C	124	77	45	14	A
	8	<input checked="" type="checkbox"/>		MPS1220-L8C	189	140	45	14	A
	10	<input type="checkbox"/>		MPS1220-L10C	214	165	45	14	A
	12	<input checked="" type="checkbox"/>		MPS1220-L12C	239	190	45	14	A
	15	<input checked="" type="checkbox"/>		MPS1220-L15C	276	227	45	14	A
	20	<input type="checkbox"/>		MPS1220-L20C	339	290	45	14	A

Drill Dia. D1 (mm)	Hole Depth (l/d)	Stock		Order Number	Dimensions (mm)				Type
		VP15TF			L1	L3	L9	D4	
12.3	3	<input checked="" type="checkbox"/>		MPS1230S-DIN	107	60	45	14	A
	3	<input checked="" type="checkbox"/>		MPS1230S-DIN-C	107	60	45	14	A
	5	<input checked="" type="checkbox"/>		MPS1230L-DIN	124	77	45	14	A
	5	<input checked="" type="checkbox"/>		MPS1230L-DIN-C	124	77	45	14	A
	8	<input checked="" type="checkbox"/>		MPS1230-L8C	189	140	45	14	A
	10	<input type="checkbox"/>		MPS1230-L10C	214	165	45	14	A
	12	<input checked="" type="checkbox"/>		MPS1230-L12C	239	190	45	14	A
	15	<input checked="" type="checkbox"/>		MPS1230-L15C	276	227	45	14	A
	20	<input type="checkbox"/>		MPS1230-L20C	339	290	45	14	A
	12.4	3	<input checked="" type="checkbox"/>		MPS1240S-DIN	107	60	45	14
3		<input checked="" type="checkbox"/>		MPS1240S-DIN-C	107	60	45	14	A
5		<input checked="" type="checkbox"/>		MPS1240L-DIN	124	77	45	14	A
5		<input checked="" type="checkbox"/>		MPS1240L-DIN-C	124	77	45	14	A
8		<input checked="" type="checkbox"/>		MPS1240-L8C	189	140	45	14	A
10		<input type="checkbox"/>		MPS1240-L10C	214	165	45	14	A
12		<input checked="" type="checkbox"/>		MPS1240-L12C	239	190	45	14	A
15		<input checked="" type="checkbox"/>		MPS1240-L15C	276	227	45	14	A
20		<input type="checkbox"/>		MPS1240-L20C	339	290	45	14	A
12.5		3	<input checked="" type="checkbox"/>		MPS1250S-DIN	107	60	45	14
	3	<input checked="" type="checkbox"/>		MPS1250S-DIN-C	107	60	45	14	A
	5	<input checked="" type="checkbox"/>		MPS1250L-DIN	124	77	45	14	A
	5	<input checked="" type="checkbox"/>		MPS1250L-DIN-C	124	77	45	14	A
	8	<input checked="" type="checkbox"/>		MPS1250-L8C	189	140	45	14	A
	10	<input type="checkbox"/>		MPS1250-L10C	214	165	45	14	A
	12	<input checked="" type="checkbox"/>		MPS1250-L12C	239	190	45	14	A
	15	<input checked="" type="checkbox"/>		MPS1250-L15C	276	227	45	14	A
	20	<input type="checkbox"/>		MPS1250-L20C	339	290	45	14	A
	12.6	3	<input checked="" type="checkbox"/>		MPS1260S-DIN	107	60	45	14
3		<input checked="" type="checkbox"/>		MPS1260S-DIN-C	107	60	45	14	A
5		<input checked="" type="checkbox"/>		MPS1260L-DIN	124	77	45	14	A
5		<input checked="" type="checkbox"/>		MPS1260L-DIN-C	124	77	45	14	A
8		<input checked="" type="checkbox"/>		MPS1260-L8C	194	145	45	14	A
10		<input type="checkbox"/>		MPS1260-L10C	220	171	45	14	A
12		<input checked="" type="checkbox"/>		MPS1260-L12C	246	197	45	14	A
15		<input checked="" type="checkbox"/>		MPS1260-L15C	285	236	45	14	A
20		<input type="checkbox"/>		MPS1260-L20C	350	301	45	14	A
12.7		3	<input checked="" type="checkbox"/>		MPS1270S-DIN	107	60	45	14
	3	<input checked="" type="checkbox"/>		MPS1270S-DIN-C	107	60	45	14	A
	5	<input checked="" type="checkbox"/>		MPS1270L-DIN	124	77	45	14	A
	5	<input checked="" type="checkbox"/>		MPS1270L-DIN-C	124	77	45	14	A
	8	<input checked="" type="checkbox"/>		MPS1270-L8C	194	145	45	14	A
	10	<input type="checkbox"/>		MPS1270-L10C	220	171	45	14	A
	12	<input checked="" type="checkbox"/>		MPS1270-L12C	246	197	45	14	A
	15	<input checked="" type="checkbox"/>		MPS1270-L15C	285	236	45	14	A
	20	<input type="checkbox"/>		MPS1270-L20C	350	301	45	14	A
	12.8	3	<input checked="" type="checkbox"/>		MPS1280S-DIN	107	60	45	14
3		<input checked="" type="checkbox"/>		MPS1280S-DIN-C	107	60	45	14	A
5		<input checked="" type="checkbox"/>		MPS1280L-DIN	124	77	45	14	A
5		<input checked="" type="checkbox"/>		MPS1280L-DIN-C	124	77	45	14	A
8		<input checked="" type="checkbox"/>		MPS1280-L8C	194	145	45	14	A
10		<input type="checkbox"/>		MPS1280-L10C	220	171	45	14	A
12		<input checked="" type="checkbox"/>		MPS1280-L12C	246	197	45	14	A
15		<input checked="" type="checkbox"/>		MPS1280-L15C	285	236	45	14	A
20		<input type="checkbox"/>		MPS1280-L20C	350	301	45	14	A

DRILLING (SOLID CARBIDE)

MPS

- From 3—40 l/d hole depth.
- MPS double margin type for accurate and reliable drilling.
- All drills with through coolant holes as standard.



D1 Tolerance	3.0≤D1≤6.0	6.0<D1≤10.0	10.0<D1≤18.0	18.0<D1≤20.0
DIN type	0.010 -0.002	0.010 -0.005	0.005 -0.013	0.005 -0.016
Others	0 -0.012	0 -0.015	0 -0.018	0 -0.021

* MPS-DIN type see table above. Other MPS drills h7 tolerance.

● Type A Double margin type

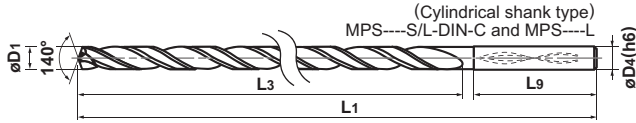

- MPS---S/L-DIN (l/d 3—5)
- MPS---S/L-DIN-C (l/d 3—5)
- MPS---L (l/d 8—40)

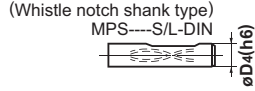

Drill Dia. D1 (mm)	Hole Depth (l/d)	Stock		Order Number	Dimensions (mm)				Type
		VP15TF			L1	L3	L9	D4	
12.9	3	●		MPS1290S-DIN	107	60	45	14	A
	3	●		MPS1290S-DIN-C	107	60	45	14	A
	5	●		MPS1290L-DIN	124	77	45	14	A
	5	●		MPS1290L-DIN-C	124	77	45	14	A
	8	●		MPS1290-L8C	194	145	45	14	A
	10	□		MPS1290-L10C	220	171	45	14	A
	12	●		MPS1290-L12C	246	197	45	14	A
	15	●		MPS1290-L15C	285	236	45	14	A
20	□		MPS1290-L20C	350	301	45	14	A	
13.0	3	●		MPS1300S-DIN	107	60	45	14	A
	3	●		MPS1300S-DIN-C	107	60	45	14	A
	5	●		MPS1300L-DIN	124	77	45	14	A
	5	●		MPS1300L-DIN-C	124	77	45	14	A
	8	●		MPS1300-L8C	194	145	45	14	A
	10	□		MPS1300-L10C	220	171	45	14	A
	12	●		MPS1300-L12C	246	197	45	14	A
	15	●		MPS1300-L15C	285	236	45	14	A
20	●		MPS1300-L20C	350	301	45	14	A	
13.1	3	●		MPS1310S-DIN	107	60	45	14	A
	3	●		MPS1310S-DIN-C	107	60	45	14	A
	5	●		MPS1310L-DIN	124	77	45	14	A
	5	●		MPS1310L-DIN-C	124	77	45	14	A
	8	●		MPS1310-L8C	200	151	45	14	A
	10	□		MPS1310-L10C	227	178	45	14	A
	12	●		MPS1310-L12C	254	205	45	14	A
	15	●		MPS1310-L15C	294	245	45	14	A
20	□		MPS1310-L20C	362	313	45	14	A	
13.2	3	●		MPS1320S-DIN	107	60	45	14	A
	3	●		MPS1320S-DIN-C	107	60	45	14	A
	5	●		MPS1320L-DIN	124	77	45	14	A
	5	●		MPS1320L-DIN-C	124	77	45	14	A
	8	●		MPS1320-L8C	200	151	45	14	A
	10	□		MPS1320-L10C	227	178	45	14	A
	12	●		MPS1320-L12C	254	205	45	14	A
	15	●		MPS1320-L15C	294	245	45	14	A
20	□		MPS1320-L20C	362	313	45	14	A	
13.3	3	●		MPS1330S-DIN	107	60	45	14	A
	3	●		MPS1330S-DIN-C	107	60	45	14	A
	5	●		MPS1330L-DIN	124	77	45	14	A
	5	●		MPS1330L-DIN-C	124	77	45	14	A
	8	●		MPS1330-L8C	200	151	45	14	A
	10	□		MPS1330-L10C	227	178	45	14	A

Drill Dia. D1 (mm)	Hole Depth (l/d)	Stock		Order Number	Dimensions (mm)				Type
		VP15TF			L1	L3	L9	D4	
13.3	12	●		MPS1330-L12C	254	205	45	14	A
	15	●		MPS1330-L15C	294	245	45	14	A
	20	□		MPS1330-L20C	362	313	45	14	A
	13.4	3	●		MPS1340S-DIN	107	60	45	14
3		●		MPS1340S-DIN-C	107	60	45	14	A
5		●		MPS1340L-DIN	124	77	45	14	A
5		●		MPS1340L-DIN-C	124	77	45	14	A
8		●		MPS1340-L8C	200	151	45	14	A
10		□		MPS1340-L10C	227	178	45	14	A
12		●		MPS1340-L12C	254	205	45	14	A
15		●		MPS1340-L15C	294	245	45	14	A
20	□		MPS1340-L20C	362	313	45	14	A	
13.5	3	●		MPS1350S-DIN	107	60	45	14	A
	3	●		MPS1350S-DIN-C	107	60	45	14	A
	5	●		MPS1350L-DIN	124	77	45	14	A
	5	●		MPS1350L-DIN-C	124	77	45	14	A
	8	●		MPS1350-L8C	200	151	45	14	A
	10	□		MPS1350-L10C	227	178	45	14	A
	12	●		MPS1350-L12C	254	205	45	14	A
	15	●		MPS1350-L15C	294	245	45	14	A
20	●		MPS1350-L20C	362	313	45	14	A	
13.6	3	●		MPS1360S-DIN	107	60	45	14	A
	3	●		MPS1360S-DIN-C	107	60	45	14	A
	5	●		MPS1360L-DIN	124	77	45	14	A
	5	●		MPS1360L-DIN-C	124	77	45	14	A
	8	●		MPS1360-L8C	205	156	45	14	A
	10	□		MPS1360-L10C	233	184	45	14	A
	12	●		MPS1360-L12C	261	212	45	14	A
	15	●		MPS1360-L15C	303	254	45	14	A
20	□		MPS1360-L20C	373	324	45	14	A	
13.7	3	●		MPS1370S-DIN	107	60	45	14	A
	3	●		MPS1370S-DIN-C	107	60	45	14	A
	5	●		MPS1370L-DIN	124	77	45	14	A
	5	●		MPS1370L-DIN-C	124	77	45	14	A
	8	●		MPS1370-L8C	205	156	45	14	A
	10	□		MPS1370-L10C	233	184	45	14	A
	12	●		MPS1370-L12C	261	212	45	14	A
	15	●		MPS1370-L15C	303	254	45	14	A
20	□		MPS1370-L20C	373	324	45	14	A	
13.8	3	●		MPS1380S-DIN	107	60	45	14	A
	3	●		MPS1380S-DIN-C	107	60	45	14	A
	5	●		MPS1380L-DIN	124	77	45	14	A

DRILLING MPS DRILLS

DRILLING

 Ø 12.9 ~ 13.8

- : Stock Standard.
- ★ : Stock Standard in Japan.
- : Non stock, produced to order only.

Drill Dia. D1 (mm)	Hole Depth (l/d)	Stock		Order Number	Dimensions (mm)				Type
		VP15TF			L1	L3	L9	D4	
13.8	5	●		MPS1380L-DIN-C	124	77	45	14	A
	8	●		MPS1380-L8C	205	156	45	14	A
	10	□		MPS1380-L10C	233	184	45	14	A
	12	●		MPS1380-L12C	261	212	45	14	A
	15	●		MPS1380-L15C	303	254	45	14	A
	20	□		MPS1380-L20C	373	324	45	14	A
13.9	3	●		MPS1390S-DIN	107	60	45	14	A
	3	●		MPS1390S-DIN-C	107	60	45	14	A
	5	●		MPS1390L-DIN	124	77	45	14	A
	5	●		MPS1390L-DIN-C	124	77	45	14	A
	8	●		MPS1390-L8C	205	156	45	14	A
	10	□		MPS1390-L10C	233	184	45	14	A
	12	●		MPS1390-L12C	261	212	45	14	A
	15	●		MPS1390-L15C	303	254	45	14	A
	20	□		MPS1390-L20C	373	324	45	14	A
	14.0	3	●		MPS1400S-DIN	107	60	45	14
3		●		MPS1400S-DIN-C	107	60	45	14	A
5		●		MPS1400L-DIN	124	77	45	14	A
5		●		MPS1400L-DIN-C	124	77	45	14	A
8		●		MPS1400-L8C	205	156	45	14	A
10		□		MPS1400-L10C	233	184	45	14	A
12		●		MPS1400-L12C	261	212	45	14	A
15		●		MPS1400-L15C	303	254	45	14	A
20		●		MPS1400-L20C	373	324	45	14	A
14.1	3	□		MPS1410S-DIN	114	64	48	16	A
	3	□		MPS1410S-DIN-C	114	64	48	16	A
	5	□		MPS1410L-DIN	132	82	48	16	A
	5	□		MPS1410L-DIN-C	132	82	48	16	A
14.2	3	●		MPS1420S-DIN	114	64	48	16	A
	3	●		MPS1420S-DIN-C	114	64	48	16	A
	5	●		MPS1420L-DIN	132	82	48	16	A
	5	●		MPS1420L-DIN-C	132	82	48	16	A
14.3	3	□		MPS1430S-DIN	114	64	48	16	A
	3	□		MPS1430S-DIN-C	114	64	48	16	A
	5	□		MPS1430L-DIN	132	82	48	16	A
	5	□		MPS1430L-DIN-C	132	82	48	16	A
14.4	3	□		MPS1440S-DIN	114	64	48	16	A
	3	□		MPS1440S-DIN-C	114	64	48	16	A
	5	□		MPS1440L-DIN	132	82	48	16	A
14.5	5	□		MPS1440L-DIN-C	132	82	48	16	A
	3	●		MPS1450S-DIN	114	64	48	16	A
	3	●		MPS1450S-DIN-C	114	64	48	16	A
	5	●		MPS1450L-DIN	132	82	48	16	A
14.6	5	●		MPS1450L-DIN-C	132	82	48	16	A
	3	□		MPS1460S-DIN	114	64	48	16	A
	3	□		MPS1460S-DIN-C	114	64	48	16	A
	5	□		MPS1460L-DIN	132	82	48	16	A
14.7	5	□		MPS1460L-DIN-C	132	82	48	16	A
	3	□		MPS1470S-DIN	114	64	48	16	A
	3	□		MPS1470S-DIN-C	114	64	48	16	A
	5	□		MPS1470L-DIN	132	82	48	16	A
14.8	5	□		MPS1470L-DIN-C	132	82	48	16	A
	3	□		MPS1480S-DIN	114	64	48	16	A
	3	□		MPS1480S-DIN-C	114	64	48	16	A
	5	□		MPS1480L-DIN	132	82	48	16	A
14.8	5	□		MPS1480L-DIN-C	132	82	48	16	A

Drill Dia. D1 (mm)	Hole Depth (l/d)	Stock		Order Number	Dimensions (mm)				Type
		VP15TF			L1	L3	L9	D4	
14.9	3	□		MPS1490S-DIN	114	64	48	16	A
	3	□		MPS1490S-DIN-C	114	64	48	16	A
	5	□		MPS1490L-DIN	132	82	48	16	A
	5	□		MPS1490L-DIN-C	132	82	48	16	A
15.0	3	●		MPS1500S-DIN	114	64	48	16	A
	3	●		MPS1500S-DIN-C	114	64	48	16	A
	5	●		MPS1500L-DIN	132	82	48	16	A
15.1	5	●		MPS1500L-DIN-C	132	82	48	16	A
	3	□		MPS1510S-DIN	115	65	48	16	A
	3	□		MPS1510S-DIN-C	115	65	48	16	A
15.2	5	□		MPS1510L-DIN	133	83	48	16	A
	5	□		MPS1510L-DIN-C	133	83	48	16	A
	3	□		MPS1520S-DIN	115	65	48	16	A
15.3	3	□		MPS1520S-DIN-C	115	65	48	16	A
	5	□		MPS1520L-DIN	133	83	48	16	A
	5	□		MPS1520L-DIN-C	133	83	48	16	A
15.4	3	□		MPS1530S-DIN	115	65	48	16	A
	3	□		MPS1530S-DIN-C	115	65	48	16	A
	5	□		MPS1530L-DIN	133	83	48	16	A
15.5	5	□		MPS1530L-DIN-C	133	83	48	16	A
	3	□		MPS1540S-DIN	115	65	48	16	A
	3	□		MPS1540S-DIN-C	115	65	48	16	A
15.6	5	□		MPS1540L-DIN	133	83	48	16	A
	5	□		MPS1540L-DIN-C	133	83	48	16	A
	3	□		MPS1550S-DIN	115	65	48	16	A
15.7	3	□		MPS1550S-DIN-C	115	65	48	16	A
	5	□		MPS1550L-DIN	133	83	48	16	A
	5	□		MPS1550L-DIN-C	133	83	48	16	A
15.8	3	□		MPS1560S-DIN	115	65	48	16	A
	3	□		MPS1560S-DIN-C	115	65	48	16	A
	5	□		MPS1560L-DIN	133	83	48	16	A
15.9	5	□		MPS1560L-DIN-C	133	83	48	16	A
	3	□		MPS1570S-DIN	115	65	48	16	A
	3	□		MPS1570S-DIN-C	115	65	48	16	A
16.0	5	□		MPS1570L-DIN	133	83	48	16	A
	5	□		MPS1570L-DIN-C	133	83	48	16	A
	3	□		MPS1580S-DIN	115	65	48	16	A
16.1	3	□		MPS1580S-DIN-C	115	65	48	16	A
	5	□		MPS1580L-DIN	133	83	48	16	A
	5	□		MPS1580L-DIN-C	133	83	48	16	A
16.1	3	□		MPS1590S-DIN	115	65	48	16	A
	3	□		MPS1590S-DIN-C	115	65	48	16	A
	5	□		MPS1590L-DIN	133	83	48	16	A
16.1	5	□		MPS1590L-DIN-C	133	83	48	16	A
	3	●		MPS1600S-DIN	115	65	48	16	A
	3	●		MPS1600S-DIN-C	115	65	48	16	A
16.1	5	●		MPS1600L-DIN	133	83	48	16	A
	5	●		MPS1600L-DIN-C	133	83	48	16	A
	3	□		MPS1610S-DIN	123	73	48	18	A
16.1	3	□		MPS1610S-DIN-C	123	73	48	18	A
	5	□		MPS1610L-DIN	143	93	48	18	A
	5	□		MPS1610L-DIN-C	143	93	48	18	A

MPS DRILLS



Ø 13.8 ~ 16.1



DRILLING (SOLID CARBIDE)

MPS

- From 3—40 l/d hole depth.
- MPS double margin type for accurate and reliable drilling.
- All drills with through coolant holes as standard.



D1 Tolerance	3.0≤D1≤6.0	6.0<D1≤10.0	10.0<D1≤18.0	18.0<D1≤20.0
DIN type	0.010 -0.002	0.010 -0.005	0.005 -0.013	0.005 -0.016
Others	0 -0.012	0 -0.015	0 -0.018	0 -0.021

* MPS-DIN type see table above. Other MPS drills h7 tolerance.

● Type A Double margin type

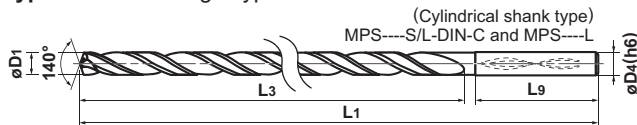

- MPS---S/L-DIN (l/d 3—5)
- MPS---S/L-DIN-C (l/d 3—5)
- MPS---L (l/d 8—40)

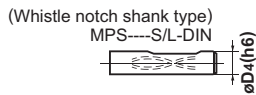

Drill Dia. D1 (mm)	Hole Depth (l/d)	Stock		Order Number	Dimensions (mm)				Type
		VP15TF			L1	L3	L9	D4	
16.2	3	<input type="checkbox"/>		MPS1620S-DIN	123	73	48	18	A
	3	<input type="checkbox"/>		MPS1620S-DIN-C	123	73	48	18	A
	5	<input type="checkbox"/>		MPS1620L-DIN	143	93	48	18	A
	5	<input type="checkbox"/>		MPS1620L-DIN-C	143	93	48	18	A
16.3	3	<input type="checkbox"/>		MPS1630S-DIN	123	73	48	18	A
	3	<input type="checkbox"/>		MPS1630S-DIN-C	123	73	48	18	A
	5	<input type="checkbox"/>		MPS1630L-DIN	143	93	48	18	A
	5	<input type="checkbox"/>		MPS1630L-DIN-C	143	93	48	18	A
16.4	3	<input type="checkbox"/>		MPS1640S-DIN	123	73	48	18	A
	3	<input type="checkbox"/>		MPS1640S-DIN-C	123	73	48	18	A
	5	<input type="checkbox"/>		MPS1640L-DIN	143	93	48	18	A
	5	<input type="checkbox"/>		MPS1640L-DIN-C	143	93	48	18	A
16.5	3	<input checked="" type="checkbox"/>		MPS1650S-DIN	123	73	48	18	A
	3	<input checked="" type="checkbox"/>		MPS1650S-DIN-C	123	73	48	18	A
	5	<input checked="" type="checkbox"/>		MPS1650L-DIN	143	93	48	18	A
	5	<input checked="" type="checkbox"/>		MPS1650L-DIN-C	143	93	48	18	A
16.6	3	<input type="checkbox"/>		MPS1660S-DIN	123	73	48	18	A
	3	<input type="checkbox"/>		MPS1660S-DIN-C	123	73	48	18	A
	5	<input type="checkbox"/>		MPS1660L-DIN	143	93	48	18	A
	5	<input type="checkbox"/>		MPS1660L-DIN-C	143	93	48	18	A
16.7	3	<input type="checkbox"/>		MPS1670S-DIN	123	73	48	18	A
	3	<input type="checkbox"/>		MPS1670S-DIN-C	123	73	48	18	A
	5	<input type="checkbox"/>		MPS1670L-DIN	143	93	48	18	A
	5	<input type="checkbox"/>		MPS1670L-DIN-C	143	93	48	18	A
16.8	3	<input type="checkbox"/>		MPS1680S-DIN	123	73	48	18	A
	3	<input type="checkbox"/>		MPS1680S-DIN-C	123	73	48	18	A
	5	<input type="checkbox"/>		MPS1680L-DIN	143	93	48	18	A
	5	<input type="checkbox"/>		MPS1680L-DIN-C	143	93	48	18	A
16.9	3	<input type="checkbox"/>		MPS1690S-DIN	123	73	48	18	A
	3	<input type="checkbox"/>		MPS1690S-DIN-C	123	73	48	18	A
	5	<input type="checkbox"/>		MPS1690L-DIN	143	93	48	18	A
	5	<input type="checkbox"/>		MPS1690L-DIN-C	143	93	48	18	A
17.0	3	<input checked="" type="checkbox"/>		MPS1700S-DIN	123	73	48	18	A
	3	<input checked="" type="checkbox"/>		MPS1700S-DIN-C	123	73	48	18	A
	5	<input checked="" type="checkbox"/>		MPS1700L-DIN	143	93	48	18	A
	5	<input checked="" type="checkbox"/>		MPS1700L-DIN-C	143	93	48	18	A
17.1	3	<input type="checkbox"/>		MPS1710S-DIN	123	73	48	18	A
	3	<input type="checkbox"/>		MPS1710S-DIN-C	123	73	48	18	A
	5	<input type="checkbox"/>		MPS1710L-DIN	143	93	48	18	A
	5	<input type="checkbox"/>		MPS1710L-DIN-C	143	93	48	18	A
17.2	3	<input type="checkbox"/>		MPS1720S-DIN	123	73	48	18	A
	3	<input type="checkbox"/>		MPS1720S-DIN-C	123	73	48	18	A

Drill Dia. D1 (mm)	Hole Depth (l/d)	Stock		Order Number	Dimensions (mm)				Type
		VP15TF			L1	L3	L9	D4	
17.2	5	<input type="checkbox"/>		MPS1720L-DIN	143	93	48	18	A
	5	<input type="checkbox"/>		MPS1720L-DIN-C	143	93	48	18	A
17.3	3	<input type="checkbox"/>		MPS1730S-DIN	123	73	48	18	A
	3	<input type="checkbox"/>		MPS1730S-DIN-C	123	73	48	18	A
	5	<input type="checkbox"/>		MPS1730L-DIN	143	93	48	18	A
	5	<input type="checkbox"/>		MPS1730L-DIN-C	143	93	48	18	A
17.4	3	<input type="checkbox"/>		MPS1740S-DIN	123	73	48	18	A
	3	<input type="checkbox"/>		MPS1740S-DIN-C	123	73	48	18	A
	5	<input type="checkbox"/>		MPS1740L-DIN-C	143	93	48	18	A
17.5	3	<input checked="" type="checkbox"/>		MPS1750S-DIN	123	73	48	18	A
	3	<input checked="" type="checkbox"/>		MPS1750S-DIN-C	123	73	48	18	A
	5	<input checked="" type="checkbox"/>		MPS1750L-DIN	143	93	48	18	A
	5	<input checked="" type="checkbox"/>		MPS1750L-DIN-C	143	93	48	18	A
17.6	3	<input type="checkbox"/>		MPS1760S-DIN	123	73	48	18	A
	3	<input type="checkbox"/>		MPS1760S-DIN-C	123	73	48	18	A
	5	<input type="checkbox"/>		MPS1760L-DIN-C	143	93	48	18	A
17.7	3	<input type="checkbox"/>		MPS1770S-DIN	123	73	48	18	A
	3	<input type="checkbox"/>		MPS1770S-DIN-C	123	73	48	18	A
	5	<input type="checkbox"/>		MPS1770L-DIN	143	93	48	18	A
	5	<input type="checkbox"/>		MPS1770L-DIN-C	143	93	48	18	A
17.8	3	<input type="checkbox"/>		MPS1780S-DIN	123	73	48	18	A
	3	<input type="checkbox"/>		MPS1780S-DIN-C	123	73	48	18	A
	5	<input type="checkbox"/>		MPS1780L-DIN	143	93	48	18	A
	5	<input type="checkbox"/>		MPS1780L-DIN-C	143	93	48	18	A
17.9	3	<input type="checkbox"/>		MPS1790S-DIN	123	73	48	18	A
	3	<input type="checkbox"/>		MPS1790S-DIN-C	123	73	48	18	A
	5	<input type="checkbox"/>		MPS1790L-DIN	143	93	48	18	A
	5	<input type="checkbox"/>		MPS1790L-DIN-C	143	93	48	18	A
18.0	3	<input checked="" type="checkbox"/>		MPS1800S-DIN	123	73	48	18	A
	3	<input checked="" type="checkbox"/>		MPS1800S-DIN-C	123	73	48	18	A
	5	<input checked="" type="checkbox"/>		MPS1800L-DIN	143	93	48	18	A
	5	<input checked="" type="checkbox"/>		MPS1800L-DIN-C	143	93	48	18	A
18.1	3	<input type="checkbox"/>		MPS1810S-DIN	131	79	50	20	A
	3	<input type="checkbox"/>		MPS1810S-DIN-C	131	79	50	20	A
	5	<input type="checkbox"/>		MPS1810L-DIN-C	153	101	50	20	A
18.2	3	<input type="checkbox"/>		MPS1820S-DIN	131	79	50	20	A
	3	<input type="checkbox"/>		MPS1820S-DIN-C	131	79	50	20	A
	5	<input type="checkbox"/>		MPS1820L-DIN	153	101	50	20	A

DRILLING MPS DRILLS



Ø 16.2 ~ 18.2

- : Stock Standard.
- ★ : Stock Standard in Japan.
- : Non stock, produced to order only.

Drill Dia. D1 (mm)	Hole Depth (l/d)	Stock		Order Number	Dimensions (mm)				Type
		VP15TF			L1	L3	L9	D4	
18.3	3	<input type="checkbox"/>		MPS1830S-DIN	131	79	50	20	A
	3	<input type="checkbox"/>		MPS1830S-DIN-C	131	79	50	20	A
	5	<input type="checkbox"/>		MPS1830L-DIN	153	101	50	20	A
	5	<input type="checkbox"/>		MPS1830L-DIN-C	153	101	50	20	A
18.4	3	<input type="checkbox"/>		MPS1840S-DIN	131	79	50	20	A
	3	<input type="checkbox"/>		MPS1840S-DIN-C	131	79	50	20	A
	5	<input type="checkbox"/>		MPS1840L-DIN	153	101	50	20	A
	5	<input type="checkbox"/>		MPS1840L-DIN-C	153	101	50	20	A
18.5	3	<input checked="" type="checkbox"/>		MPS1850S-DIN	131	79	50	20	A
	3	<input checked="" type="checkbox"/>		MPS1850S-DIN-C	131	79	50	20	A
	5	<input checked="" type="checkbox"/>		MPS1850L-DIN	153	101	50	20	A
	5	<input checked="" type="checkbox"/>		MPS1850L-DIN-C	153	101	50	20	A
18.6	3	<input type="checkbox"/>		MPS1860S-DIN	131	79	50	20	A
	3	<input type="checkbox"/>		MPS1860S-DIN-C	131	79	50	20	A
	5	<input type="checkbox"/>		MPS1860L-DIN	153	101	50	20	A
	5	<input type="checkbox"/>		MPS1860L-DIN-C	153	101	50	20	A
18.7	3	<input type="checkbox"/>		MPS1870S-DIN	131	79	50	20	A
	3	<input type="checkbox"/>		MPS1870S-DIN-C	131	79	50	20	A
	5	<input type="checkbox"/>		MPS1870L-DIN	153	101	50	20	A
	5	<input type="checkbox"/>		MPS1870L-DIN-C	153	101	50	20	A
18.8	3	<input type="checkbox"/>		MPS1880S-DIN	131	79	50	20	A
	3	<input type="checkbox"/>		MPS1880S-DIN-C	131	79	50	20	A
	5	<input type="checkbox"/>		MPS1880L-DIN	153	101	50	20	A
	5	<input type="checkbox"/>		MPS1880L-DIN-C	153	101	50	20	A
18.9	3	<input type="checkbox"/>		MPS1890S-DIN	131	79	50	20	A
	3	<input type="checkbox"/>		MPS1890S-DIN-C	131	79	50	20	A
	5	<input type="checkbox"/>		MPS1890L-DIN	153	101	50	20	A
	5	<input type="checkbox"/>		MPS1890L-DIN-C	153	101	50	20	A
19.0	3	<input checked="" type="checkbox"/>		MPS1900S-DIN	131	79	50	20	A
	3	<input checked="" type="checkbox"/>		MPS1900S-DIN-C	131	79	50	20	A
	5	<input checked="" type="checkbox"/>		MPS1900L-DIN	153	101	50	20	A
	5	<input checked="" type="checkbox"/>		MPS1900L-DIN-C	153	101	50	20	A
19.1	3	<input type="checkbox"/>		MPS1910S-DIN	131	79	50	20	A
	3	<input type="checkbox"/>		MPS1910S-DIN-C	131	79	50	20	A
	5	<input type="checkbox"/>		MPS1910L-DIN	153	101	50	20	A
	5	<input type="checkbox"/>		MPS1910L-DIN-C	153	101	50	20	A

Drill Dia. D1 (mm)	Hole Depth (l/d)	Stock		Order Number	Dimensions (mm)				Type
		VP15TF			L1	L3	L9	D4	
19.2	3	<input type="checkbox"/>		MPS1920S-DIN	131	79	50	20	A
	3	<input type="checkbox"/>		MPS1920S-DIN-C	131	79	50	20	A
	5	<input type="checkbox"/>		MPS1920L-DIN	153	101	50	20	A
	5	<input type="checkbox"/>		MPS1920L-DIN-C	153	101	50	20	A
19.3	3	<input type="checkbox"/>		MPS1930S-DIN	131	79	50	20	A
	3	<input type="checkbox"/>		MPS1930S-DIN-C	131	79	50	20	A
	5	<input type="checkbox"/>		MPS1930L-DIN	153	101	50	20	A
	5	<input type="checkbox"/>		MPS1930L-DIN-C	153	101	50	20	A
19.4	3	<input type="checkbox"/>		MPS1940S-DIN	131	79	50	20	A
	3	<input type="checkbox"/>		MPS1940S-DIN-C	131	79	50	20	A
	5	<input type="checkbox"/>		MPS1940L-DIN	153	101	50	20	A
	5	<input type="checkbox"/>		MPS1940L-DIN-C	153	101	50	20	A
19.5	3	<input checked="" type="checkbox"/>		MPS1950S-DIN	131	79	50	20	A
	3	<input checked="" type="checkbox"/>		MPS1950S-DIN-C	131	79	50	20	A
	5	<input checked="" type="checkbox"/>		MPS1950L-DIN	153	101	50	20	A
	5	<input checked="" type="checkbox"/>		MPS1950L-DIN-C	153	101	50	20	A
19.6	3	<input type="checkbox"/>		MPS1960S-DIN	131	79	50	20	A
	3	<input type="checkbox"/>		MPS1960S-DIN-C	131	79	50	20	A
	5	<input type="checkbox"/>		MPS1960L-DIN	153	101	50	20	A
	5	<input type="checkbox"/>		MPS1960L-DIN-C	153	101	50	20	A
19.7	3	<input type="checkbox"/>		MPS1970S-DIN	131	79	50	20	A
	3	<input type="checkbox"/>		MPS1970S-DIN-C	131	79	50	20	A
	5	<input type="checkbox"/>		MPS1970L-DIN	153	101	50	20	A
	5	<input type="checkbox"/>		MPS1970L-DIN-C	153	101	50	20	A
19.8	3	<input type="checkbox"/>		MPS1980S-DIN	131	79	50	20	A
	3	<input type="checkbox"/>		MPS1980S-DIN-C	131	79	50	20	A
	5	<input type="checkbox"/>		MPS1980L-DIN	153	101	50	20	A
	5	<input type="checkbox"/>		MPS1980L-DIN-C	153	101	50	20	A
19.9	3	<input type="checkbox"/>		MPS1990S-DIN	131	79	50	20	A
	3	<input type="checkbox"/>		MPS1990S-DIN-C	131	79	50	20	A
	5	<input type="checkbox"/>		MPS1990L-DIN	153	101	50	20	A
	5	<input type="checkbox"/>		MPS1990L-DIN-C	153	101	50	20	A
20.0	3	<input checked="" type="checkbox"/>		MPS2000S-DIN	131	79	50	20	A
	3	<input checked="" type="checkbox"/>		MPS2000S-DIN-C	131	79	50	20	A
	5	<input checked="" type="checkbox"/>		MPS2000L-DIN	153	101	50	20	A
	5	<input checked="" type="checkbox"/>		MPS2000L-DIN-C	153	101	50	20	A

MPS DRILLS



Ø 18.3 ~ 20.0

DRILLING (SOLID CARBIDE)

MPS



RECOMMENDED CUTTING CONDITIONS

MPS DRILL (3xD, 5xD, 8xD, 12xD)

Work Material	Drill Diameter Conditions Hardness	φ3.0-φ6.0		φ6.0-φ10.0		φ10.0-φ14.0		φ14.0-φ20.0	
		Cutting Speed (m/min)	Feed (mm/rev)	Cutting Speed (m/min)	Feed (mm/rev)	Cutting Speed (m/min)	Feed (mm/rev)	Cutting Speed (m/min)	Feed (mm/rev)
P Mild Steel	≤ 180HB	110 (50-120)	0.20 (0.15-0.25)	130 (80-140)	0.25 (0.20-0.35)	150 (90-170)	0.30 (0.20-0.40)	160 (100-180)	0.35 (0.20-0.40)
	180-280HB	90 (50-100)	0.20 (0.15-0.25)	110 (70-120)	0.25 (0.20-0.35)	130 (80-140)	0.25 (0.20-0.40)	140 (100-150)	0.30 (0.20-0.40)
	280-350HB	80 (40-90)	0.20 (0.15-0.30)	90 (60-110)	0.25 (0.15-0.30)	110 (70-130)	0.25 (0.15-0.40)	120 (90-140)	0.30 (0.20-0.40)
M Stainless Steel	≤ 200HB	50 (20-100)	0.10 (0.05-0.15)	60 (40-120)	0.20 (0.10-0.25)	70 (50-120)	0.25 (0.15-0.30)	80 (60-120)	0.25 (0.15-0.30)
K Cast Iron	Tensile Strength ≤ 350N/mm ²	100 (70-120)	0.25 (0.15-0.30)	130 (100-140)	0.30 (0.20-0.35)	150 (110-160)	0.35 (0.25-0.40)	160 (120-170)	0.35 (0.25-0.40)
	Ductile Cast Iron Tensile Strength ≤ 450N/mm ²	60 (30-80)	0.20 (0.15-0.25)	70 (40-90)	0.20 (0.15-0.30)	90 (50-110)	0.25 (0.20-0.40)	100 (60-110)	0.3 (0.20-0.40)
S Heat Resistant Alloy	-	20 (10-25)	0.10 (0.05-0.15)	25 (15-30)	0.12 (0.05-0.15)	25 (15-30)	0.15 (0.10-0.20)	30 (25-35)	0.15 (0.10-0.20)

MPS DRILL (l/d=15-30)

Work Material	Drill Diameter Conditions Hardness	φ3.0-φ6.0		φ6.0-φ10.0		φ10.0-φ14.0	
		Cutting Speed (m/min)	Feed (mm/rev)	Cutting Speed (m/min)	Feed (mm/rev)	Cutting Speed (m/min)	Feed (mm/rev)
P Mild Steel	≤ 180HB	85 (35-100)	0.20 (0.15-0.25)	85 (45-120)	0.25 (0.15-0.35)	90 (55-120)	0.30 (0.20-0.35)
	180-280HB	80 (40-95)	0.20 (0.15-0.25)	90 (50-120)	0.25 (0.20-0.35)	90 (60-130)	0.30 (0.15-0.35)
	280-350HB	75 (35-80)	0.15 (0.15-0.20)	80 (45-115)	0.20 (0.15-0.25)	85 (55-115)	0.25 (0.15-0.30)
M Stainless Steel	≤ 200HB	50 (20-80)	0.10 (0.05-0.15)	60 (20-90)	0.12 (0.05-0.15)	70 (20-90)	0.15 (0.10-0.20)
K Cast Iron	Tensile Strength ≤ 350N/mm ²	70 (40-85)	0.25 (0.15-0.30)	75 (50-90)	0.30 (0.20-0.35)	80 (50-95)	0.35 (0.20-0.40)
	Ductile Cast Iron Tensile Strength ≤ 450N/mm ²	65 (35-80)	0.20 (0.15-0.25)	70 (45-85)	0.25 (0.15-0.30)	75 (45-90)	0.30 (0.20-0.35)
S Heat Resistant Alloy	-	20 (10-25)	0.10 (0.05-0.15)	25 (15-30)	0.12 (0.05-0.15)	25 (15-30)	0.15 (0.10-0.20)

MPS DRILL (l/d=40)

Work Material	Drill Diameter Conditions Hardness	φ3.0-φ4.0		φ5.0-φ6.0		φ6.0-φ9.0	
		Cutting Speed (m/min)	Feed (mm/rev)	Cutting Speed (m/min)	Feed (mm/rev)	Cutting Speed (m/min)	Feed (mm/rev)
P Mild Steel	≤ 180HB	60 (50-70)	0.18 (0.13-0.20)	70 (55-80)	0.20 (0.15-0.23)	75 (60-85)	0.25 (0.18-0.28)
	180-280HB	55 (40-65)	0.15 (0.10-0.18)	65 (45-75)	0.18 (0.13-0.22)	70 (55-80)	0.23 (0.15-0.25)
	280-350HB	50 (40-60)	0.12 (0.08-0.15)	55 (40-65)	0.17 (0.13-0.20)	60 (40-75)	0.20 (0.15-0.23)
M Stainless Steel	≤ 200HB	35 (30-45)	0.10 (0.07-0.15)	40 (30-50)	0.12 (0.08-0.15)	45 (30-60)	0.15 (0.13-0.20)
K Cast Iron	Tensile Strength ≤ 350N/mm ²	55 (35-70)	0.15 (0.10-0.20)	60 (40-65)	0.20 (0.15-0.23)	60 (45-70)	0.23 (0.18-0.28)
	Ductile Cast Iron Tensile Strength ≤ 450N/mm ²	45 (30-60)	0.12 (0.08-0.15)	50 (40-60)	0.17 (0.13-0.20)	55 (40-65)	0.20 (0.15-0.23)
S Heat Resistant Alloy	-	15 (10-25)	0.07 (0.05-0.10)	20 (10-25)	0.07 (0.05-0.10)	20 (10-25)	0.10 (0.06-0.12)

Machining conditions can vary greatly, please use the above tables as a reference starting point only and adjust the values according to the conditions. For drill lengths greater than l/d=10 it is recommended to drill a pilot hole.

DRILLING MPS DRILLS



CUTTING DATA

HOW TO USE SUPER LONG DRILLS

● Drilling a blind hole

■ 1. Drilling a pilot hole

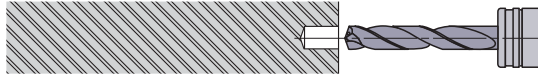

- ① Use a drill with a larger (flatter) point angle than the super long type. Mitsubishi type MPS is recommended.
- ② Ensure a high precision hole is drilled for the guide.
- ③ Drill depth : Approx 1D or deeper.
(Adjust the pilot hole depth according to the length of the super long type.)

■ 2. Initial cutting with the long type drill

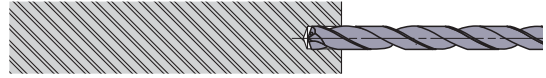

- ① Penetrate the pilot hole at low revolution. (Cutting speed 20–30m/min, feed rate 0.2–0.3mm/rev)
- ② Stop the long type drill 1–3mm short of the pilot hole bottom.

■ 3. Drill the deep hole

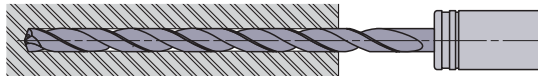

- ① Start cutting at the recommended speed and feed with a non-peck (continuous feed) cycle.

■ 4. Drill retraction

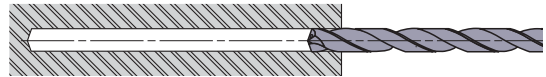

- ① After drilling, lower the cutting revolution about 1–2mm short of the hole end. (Cutting speed of around 20–30m/min)
- ② Retract the drill to the pilot hole depth starting point at a feed rate of 3000mm/min.
- ③ Finally, clear the hole at a cutting speed of 20–30m/min and feed rate of 0.2–0.3mm/rev.

● Drilling and breaking through on irregular faces or angles

■ 1. Spot facing

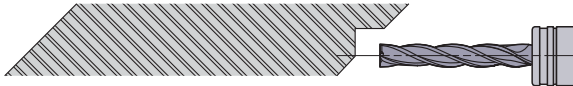

- ① Machine a flat or the irregular face by using an end mill or slot drill capable of spot facing. Make the spot face diameter the same size as the required deep hole diameter.

■ 2. Drilling a pilot hole

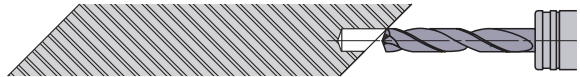

- ① Use a drill with a larger (flatter) point angle than the super long type. Mitsubishi type MPS is recommended.
- ② Ensure a high precision hole is drilled for the guide.
- ③ Drill depth : Approx 1D or deeper.
(Adjust the pilot hole depth according to the length of the super long type.)

■ 3. Initial cutting with the long type drill

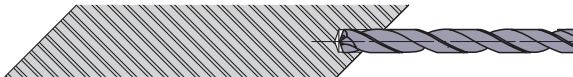

- ① Penetrate the pilot hole at a low revolution. (Cutting speed 20–30m/min, feed rate 0.2–0.3mm/rev)
- ② Stop the long type drill 1–3mm short of the pilot hole bottom.

■ 4. Drill the deep hole

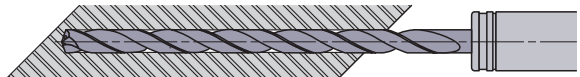

- ① Start cutting at the recommended speed and feed with a non-peck (continuous feed) cycle.

■ 5. Breaking through

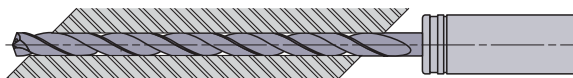

- ① When breaking through, the cutting edge can be damaged.
- ② A feed rate of 0.05–0.1mm/rev is recommended.

■ 6. Drill retraction

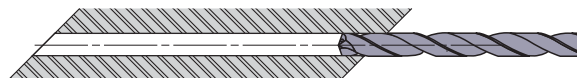

- ① Retract the drill to the pilot hole depth starting point at a feed rate of 3000mm/min.
- ② Finally clear the hole at a cutting speed of 20–30m/min and feed rate of 0.2–0.3mm/rev.



MSL SUPER LONG

2 Margin MSL Solid Carbide Super Long drill for deep hole drilling 20xD ~ 30xD.



PRECISION
FOR SUCCESS

CHOOSE JAPAN'S NO. 1

MITSUBISHI
MITSUBISHI MATERIALS

www.mitsubishicarbide.com

MIRACLE[®] coated 2 Margin Solid carbide drill MSL

Features

- Wavy cutting edge & special flute geometry to promote smooth chip evacuation

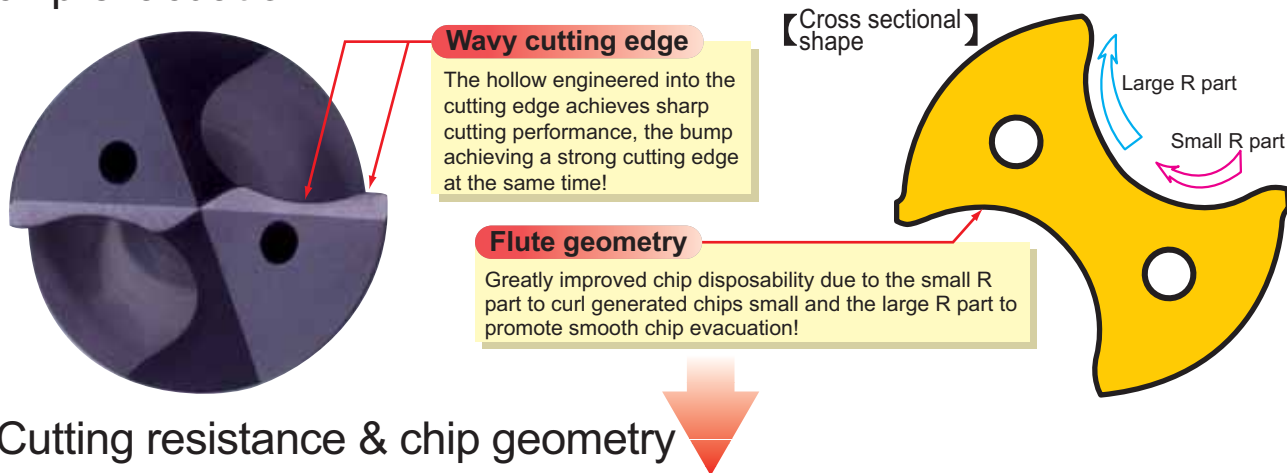

- Cutting resistance & chip geometry

MSL lower cutting resistance and power consumption, exhibiting excellent chip disposability with compact chip discharge!

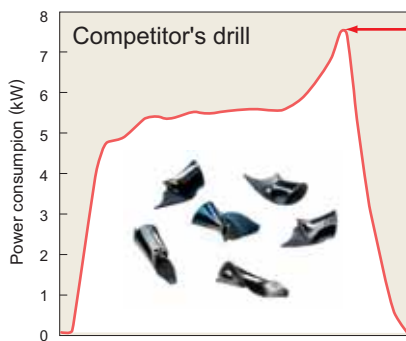
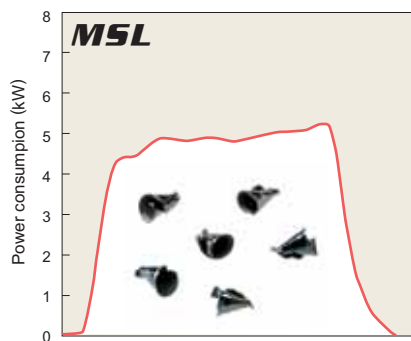

Chip packing occurred just before breaking through

<Cutting conditions>

Workpiece : Cf53 (1.1213) 150-180HB
Drill diameter : \varnothing 12 (Internal coolant)
Hole depth : 70mm
Cutting speed : 120m/min
Feed : 0.25mm/rev
Collant : WSO
Oil pressure : 0.5MPa

- Long tool life **MIRACLE[®]** coated

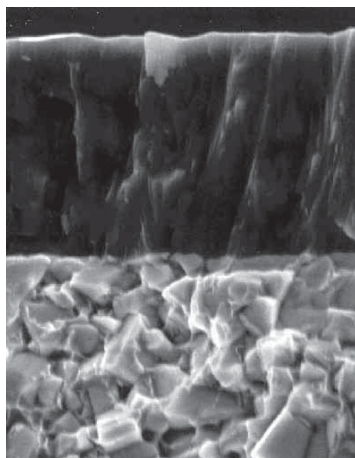

Miracle coated
(Al, Ti)N

TF15 micrograin
cemented carbide



Features of **VP15TF**

Miracle coated **VP15TF** displays high welding resistance therefore it can be used for machining a wide range of workpiece materials such as Mild steels, Carbon steels, Alloy steel Stainless steels and Cast irons.

VP15TF

MSL SUPER LONG DRILLS

DRILLING

FEATURES

DRILLING (SOLID CARBIDE)

MSL

- From 20—30 l/d hole depth.
- MSL 2 margin type for accurate and reliable drilling.
- All drills with through coolant holes as standard.



D1 Tolerance	3.0 ≤ D1 ≤ 6.0	6.0 < D1 ≤ 10.0	10.0 < D1 ≤ 18.0	18.0 < D1 ≤ 20.0
DIN type	0.010 -0.002	0.010 -0.005	0.005 -0.013	0.005 -0.016
Others	0 -0.012	0 -0.015	0 -0.018	0 -0.021

* MPS-DIN type see table above. Other MPS drills h7 tolerance.

● Type B 2 margin type

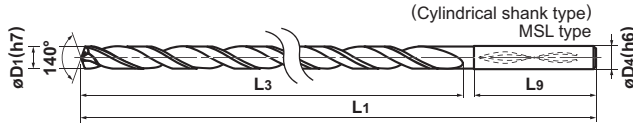

MSL (l/d 20—30)

MSL SUPER LONG DRILLS

Drill Dia. D1 (mm)	Hole Depth (l/d)	Stock VP15TF	Order Number	Dimensions (mm)				Type
				L1	L3	L9	D4	
3.0	20	●	MSL0300-L20C	110	70	36	6	B
	25	●	MSL0300-L25C	125	85	36	6	B
	30	●	MSL0300-L30C	140	100	36	6	B
3.1	20	●	MSL0310-L20C	122	82	36	6	B
	25	●	MSL0310-L25C	139	99	36	6	B
	30	●	MSL0310-L30C	157	117	36	6	B
3.2	20	●	MSL0320-L20C	122	82	36	6	B
	25	●	MSL0320-L25C	139	99	36	6	B
	30	●	MSL0320-L30C	157	117	36	6	B
3.3	20	●	MSL0330-L20C	122	82	36	6	B
	25	●	MSL0330-L25C	139	99	36	6	B
	30	●	MSL0330-L30C	157	117	36	6	B
3.4	20	●	MSL0340-L20C	122	82	36	6	B
	25	●	MSL0340-L25C	139	99	36	6	B
	30	●	MSL0340-L30C	157	117	36	6	B
3.5	20	●	MSL0350-L20C	122	82	36	6	B
	25	●	MSL0350-L25C	139	99	36	6	B
	30	●	MSL0350-L30C	157	117	36	6	B
3.6	20	●	MSL0360-L20C	133	93	36	6	B
	25	●	MSL0360-L25C	153	113	36	6	B
	30	●	MSL0360-L30C	173	133	36	6	B
3.7	20	●	MSL0370-L20C	133	93	36	6	B
	25	●	MSL0370-L25C	153	113	36	6	B
	30	●	MSL0370-L30C	173	133	36	6	B
3.8	20	●	MSL0380-L20C	133	93	36	6	B
	25	●	MSL0380-L25C	153	113	36	6	B
	30	●	MSL0380-L30C	173	133	36	6	B
3.9	20	●	MSL0390-L20C	133	93	36	6	B
	25	●	MSL0390-L25C	153	113	36	6	B
	30	●	MSL0390-L30C	173	133	36	6	B
4.0	20	●	MSL0400-L20C	133	93	36	6	B
	25	●	MSL0400-L25C	153	113	36	6	B
	30	●	MSL0400-L30C	173	133	36	6	B
4.1	20	●	MSL0410-L20C	145	105	36	6	B
	25	●	MSL0410-L25C	167	127	36	6	B
	30	●	MSL0410-L30C	190	150	36	6	B
4.2	20	●	MSL0420-L20C	145	105	36	6	B
	25	●	MSL0420-L25C	167	127	36	6	B
	30	●	MSL0420-L30C	190	150	36	6	B
4.3	20	●	MSL0430-L20C	145	105	36	6	B
	25	●	MSL0430-L25C	167	127	36	6	B
	30	●	MSL0430-L30C	190	150	36	6	B

Drill Dia. D1 (mm)	Hole Depth (l/d)	Stock VP15TF	Order Number	Dimensions (mm)				Type
				L1	L3	L9	D4	
4.4	20	●	MSL0440-L20C	145	105	36	6	B
	25	●	MSL0440-L25C	167	127	36	6	B
	30	●	MSL0440-L30C	190	150	36	6	B
4.5	20	●	MSL0450-L20C	145	105	36	6	B
	25	●	MSL0450-L25C	167	127	36	6	B
	30	●	MSL0450-L30C	190	150	36	6	B
4.6	20	●	MSL0460-L20C	156	116	36	6	B
	25	●	MSL0460-L25C	181	141	36	6	B
	30	●	MSL0460-L30C	206	166	36	6	B
4.7	20	●	MSL0470-L20C	156	116	36	6	B
	25	●	MSL0470-L25C	181	141	36	6	B
	30	●	MSL0470-L30C	206	166	36	6	B
4.8	20	●	MSL0480-L20C	156	116	36	6	B
	25	●	MSL0480-L25C	181	141	36	6	B
	30	●	MSL0480-L30C	206	166	36	6	B
4.9	20	●	MSL0490-L20C	156	116	36	6	B
	25	●	MSL0490-L25C	181	141	36	6	B
	30	●	MSL0490-L30C	206	166	36	6	B
5.0	20	●	MSL0500-L20C	156	116	36	6	B
	25	●	MSL0500-L25C	181	141	36	6	B
	30	●	MSL0500-L30C	206	166	36	6	B
5.1	20	●	MSL0510-L20C	168	128	36	6	B
	25	●	MSL0510-L25C	195	155	36	6	B
	30	●	MSL0510-L30C	223	183	36	6	B
5.2	20	●	MSL0520-L20C	168	128	36	6	B
	25	●	MSL0520-L25C	195	155	36	6	B
	30	●	MSL0520-L30C	223	183	36	6	B
5.3	20	●	MSL0530-L20C	168	128	36	6	B
	25	●	MSL0530-L25C	195	155	36	6	B
	30	●	MSL0530-L30C	223	183	36	6	B
5.4	20	●	MSL0540-L20C	168	128	36	6	B
	25	●	MSL0540-L25C	195	155	36	6	B
	30	●	MSL0540-L30C	223	183	36	6	B
5.5	20	●	MSL0550-L20C	168	128	36	6	B
	25	●	MSL0550-L25C	195	155	36	6	B
	30	●	MSL0550-L30C	223	183	36	6	B
5.6	20	●	MSL0560-L20C	179	139	36	6	B
	25	●	MSL0560-L25C	209	169	36	6	B
	30	●	MSL0560-L30C	239	199	36	6	B
5.7	20	●	MSL0570-L20C	179	139	36	6	B
	25	●	MSL0570-L25C	209	169	36	6	B
	30	●	MSL0570-L30C	239	199	36	6	B

- : Stock Standard
- ★ : Stock Standard in Japan.
- : Non stock, produced to order only

Drill Dia. D1 (mm)	Hole Depth (l/d)	Stock		Order Number	Dimensions (mm)				Type
		VP15TF			L1	L3	L9	D4	
5.8	20	●		MSL0580-L20C	179	139	36	6	B
	25	●		MSL0580-L25C	209	169	36	6	B
	30	●		MSL0580-L30C	239	199	36	6	B
5.9	20	●		MSL0590-L20C	179	139	36	6	B
	25	●		MSL0590-L25C	209	169	36	6	B
	30	●		MSL0590-L30C	239	199	36	6	B
6.0	20	●		MSL0600-L20C	179	139	36	6	B
	25	●		MSL0600-L25C	209	169	36	6	B
	30	●		MSL0600-L30C	239	199	36	6	B
6.1	20	●		MSL0610-L20C	191	151	36	8	B
	25	●		MSL0610-L25C	223	183	36	8	B
	30	●		MSL0610-L30C	256	216	36	8	B
6.2	20	●		MSL0620-L20C	191	151	36	8	B
	25	●		MSL0620-L25C	223	183	36	8	B
	30	●		MSL0620-L30C	256	216	36	8	B
6.3	20	●		MSL0630-L20C	191	151	36	8	B
	25	●		MSL0630-L25C	223	183	36	8	B
	30	●		MSL0630-L30C	256	216	36	8	B
6.4	20	●		MSL0640-L20C	191	151	36	8	B
	25	●		MSL0640-L25C	223	183	36	8	B
	30	●		MSL0640-L30C	256	216	36	8	B
6.5	20	●		MSL0650-L20C	191	151	36	8	B
	25	●		MSL0650-L25C	223	183	36	8	B
	30	●		MSL0650-L30C	256	216	36	8	B
6.6	20	●		MSL0660-L20C	202	162	36	8	B
	25	●		MSL0660-L25C	237	197	36	8	B
	30	●		MSL0660-L30C	272	232	36	8	B
6.7	20	●		MSL0670-L20C	202	162	36	8	B
	25	●		MSL0670-L25C	237	197	36	8	B
	30	●		MSL0670-L30C	272	232	36	8	B
6.8	20	●		MSL0680-L20C	202	162	36	8	B
	25	●		MSL0680-L25C	237	197	36	8	B
	30	●		MSL0680-L30C	272	232	36	8	B
6.9	20	●		MSL0690-L20C	202	162	36	8	B
	25	●		MSL0690-L25C	237	197	36	8	B
	30	●		MSL0690-L30C	272	232	36	8	B
7.0	20	●		MSL0700-L20C	202	162	36	8	B
	25	●		MSL0700-L25C	237	197	36	8	B
	30	●		MSL0700-L30C	272	232	36	8	B
7.1	20	●		MSL0710-L20C	214	174	36	8	B
	25	●		MSL0710-L25C	251	211	36	8	B
	30	●		MSL0710-L30C	289	249	36	8	B
7.2	20	●		MSL0720-L20C	214	174	36	8	B
	25	●		MSL0720-L25C	251	211	36	8	B
	30	●		MSL0720-L30C	289	249	36	8	B
7.3	20	●		MSL0730-L20C	214	174	36	8	B
	25	●		MSL0730-L25C	251	211	36	8	B
	30	●		MSL0730-L30C	289	249	36	8	B
7.4	20	●		MSL0740-L20C	214	174	36	8	B
	25	●		MSL0740-L25C	251	211	36	8	B
	30	●		MSL0740-L30C	289	249	36	8	B
7.5	20	●		MSL0750-L20C	214	174	36	8	B
	25	●		MSL0750-L25C	251	211	36	8	B
	30	●		MSL0750-L30C	289	249	36	8	B
7.6	20	●		MSL0760-L20C	225	185	36	8	B
	25	●		MSL0760-L25C	265	225	36	8	B
	30	●		MSL0760-L30C	305	265	36	8	B

Drill Dia. D1 (mm)	Hole Depth (l/d)	Stock		Order Number	Dimensions (mm)				Type
		VP15TF			L1	L3	L9	D4	
7.7	20	●		MSL0770-L20C	225	185	36	8	B
	25	●		MSL0770-L25C	265	225	36	8	B
	30	●		MSL0770-L30C	305	265	36	8	B
7.8	20	●		MSL0780-L20C	225	185	36	8	B
	25	●		MSL0780-L25C	265	225	36	8	B
	30	●		MSL0780-L30C	305	265	36	8	B
7.9	20	●		MSL0790-L20C	225	185	36	8	B
	25	●		MSL0790-L25C	265	225	36	8	B
	30	●		MSL0790-L30C	305	265	36	8	B
8.0	20	●		MSL0800-L20C	225	185	36	8	B
	25	●		MSL0800-L25C	265	225	36	8	B
	30	●		MSL0800-L30C	305	265	36	8	B
8.1	20	●		MSL0810-L20C	241	197	40	10	B
	25	●		MSL0810-L25C	283	239	40	10	B
	30	□		MSL0810-L30C	326	282	40	10	B
8.2	20	●		MSL0820-L20C	241	197	40	10	B
	25	●		MSL0820-L25C	283	239	40	10	B
	30	□		MSL0820-L30C	326	282	40	10	B
8.3	20	●		MSL0830-L20C	241	197	40	10	B
	25	●		MSL0830-L25C	283	239	40	10	B
	30	□		MSL0830-L30C	326	282	40	10	B
8.4	20	●		MSL0840-L20C	241	197	40	10	B
	25	●		MSL0840-L25C	283	239	40	10	B
	30	□		MSL0840-L30C	326	282	40	10	B
8.5	20	●		MSL0850-L20C	241	197	40	10	B
	25	●		MSL0850-L25C	283	239	40	10	B
	30	●		MSL0850-L30C	326	282	40	10	B
8.6	20	●		MSL0860-L20C	252	208	40	10	B
	25	●		MSL0860-L25C	297	253	40	10	B
	30	□		MSL0860-L30C	342	298	40	10	B
8.7	20	●		MSL0870-L20C	252	208	40	10	B
	25	●		MSL0870-L25C	297	253	40	10	B
	30	□		MSL0870-L30C	342	298	40	10	B
8.8	20	●		MSL0880-L20C	252	208	40	10	B
	25	●		MSL0880-L25C	297	253	40	10	B
	30	●		MSL0880-L30C	342	298	40	10	B
8.9	20	●		MSL0890-L20C	252	208	40	10	B
	25	●		MSL0890-L25C	297	253	40	10	B
	30	□		MSL0890-L30C	342	298	40	10	B
9.0	20	●		MSL0900-L20C	252	208	40	10	B
	25	●		MSL0900-L25C	297	253	40	10	B
	30	●		MSL0900-L30C	342	298	40	10	B
9.1	20	●		MSL0910-L20C	265	221	40	10	B
	25	□		MSL0910-L25C	312	268	40	10	B
	30	□		MSL0910-L30C	360	316	40	10	B
9.2	20	●		MSL0920-L20C	265	221	40	10	B
	25	□		MSL0920-L25C	312	268	40	10	B
	30	□		MSL0920-L30C	360	316	40	10	B
9.3	20	●		MSL0930-L20C	265	221	40	10	B
	25	□		MSL0930-L25C	312	268	40	10	B
	30	□		MSL0930-L30C	360	316	40	10	B
9.4	20	●		MSL0940-L20C	265	221	40	10	B
	25	□		MSL0940-L25C	312	268	40	10	B
	30	□		MSL0940-L30C	360	316	40	10	B
9.5	20	●		MSL0950-L20C	265	221	40	10	B
	25	●		MSL0950-L25C	312	268	40	10	B
	30	●		MSL0950-L30C	360	316	40	10	B

MSL SUPER LONG DRILLS



Ø 5.8 ~ 9.5

CUTTING CONDITIONS

D086

D083

DRILLING (SOLID CARBIDE)

MSL

- From 20—30 l/d hole depth.
- MSL 2 margin type for accurate and reliable drilling.
- All drills with through coolant holes as standard.



D1 Tolerance	3.0 ≤ D1 ≤ 6.0	6.0 < D1 ≤ 10.0	10.0 < D1 ≤ 18.0	18.0 < D1 ≤ 20.0
DIN type	0.010 -0.002	0.010 -0.005	0.005 -0.013	0.005 -0.016
Others	0 -0.012	0 -0.015	0 -0.018	0 -0.021

* MPS-DIN type see table above. Other MPS drills h7 tolerance.

● Type B 2 margin type

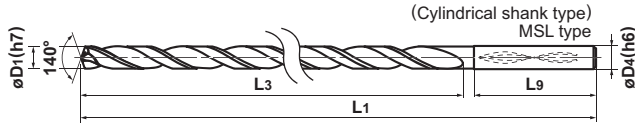

MSL (l/d 20—30)

MSL SUPER LONG DRILLS

Drill Dia. D1 (mm)	Hole Depth (l/d)	Stock VP15TF	Order Number	Dimensions (mm)				Type
				L1	L3	L9	D4	
9.6	20	●	MSL0960-L20C	276	232	40	10	B
	25	□	MSL0960-L25C	326	282	40	10	B
	30	□	MSL0960-L30C	376	332	40	10	B
9.7	20	●	MSL0970-L20C	276	232	40	10	B
	25	□	MSL0970-L25C	326	282	40	10	B
	30	□	MSL0970-L30C	376	332	40	10	B
9.8	20	●	MSL0980-L20C	276	232	40	10	B
	25	□	MSL0980-L25C	326	282	40	10	B
	30	□	MSL0980-L30C	376	332	40	10	B
9.9	20	●	MSL0990-L20C	276	232	40	10	B
	25	□	MSL0990-L25C	326	282	40	10	B
	30	□	MSL0990-L30C	376	332	40	10	B
10.0	20	●	MSL1000-L20C	276	232	40	10	B
	25	●	MSL1000-L25C	326	282	40	10	B
	30	●	MSL1000-L30C	376	332	40	10	B
10.1	20	●	MSL1010-L20C	293	244	40	10	B
	25	□	MSL1010-L25C	345	296	40	10	B
10.2	20	●	MSL1020-L20C	293	244	40	10	B
	25	□	MSL1020-L25C	345	296	40	10	B
10.3	20	●	MSL1030-L20C	293	244	45	12	B
	25	□	MSL1030-L25C	345	296	45	12	B
10.4	20	●	MSL1040-L20C	293	244	45	12	B
	25	□	MSL1040-L25C	345	296	45	12	B
10.5	20	●	MSL1050-L20C	293	244	45	12	B
	25	●	MSL1050-L25C	345	296	45	12	B
10.6	20	●	MSL1060-L20C	304	255	45	12	B
	25	□	MSL1060-L25C	359	310	45	12	B
10.7	20	●	MSL1070-L20C	304	255	45	12	B
	25	□	MSL1070-L25C	359	310	45	12	B
10.8	20	●	MSL1080-L20C	304	255	45	12	B
	25	□	MSL1080-L25C	359	310	45	12	B
10.9	20	●	MSL1090-L20C	304	255	45	12	B
	25	□	MSL1090-L25C	359	310	45	12	B
11.0	20	●	MSL1100-L20C	304	255	45	12	B
	25	●	MSL1100-L25C	359	310	45	12	B
11.1	20	□	MSL1110-L20C	316	267	45	12	B
	25	□	MSL1110-L25C	373	324	45	12	B
11.2	20	□	MSL1120-L20C	316	267	45	12	B
	25	□	MSL1120-L25C	373	324	45	12	B
11.3	20	□	MSL1130-L20C	316	267	45	12	B
	25	□	MSL1130-L25C	373	324	45	12	B
11.4	20	□	MSL1140-L20C	316	267	45	12	B
	25	□	MSL1140-L25C	373	324	45	12	B

Drill Dia. D1 (mm)	Hole Depth (l/d)	Stock VP15TF	Order Number	Dimensions (mm)				Type
				L1	L3	L9	D4	
11.5	20	●	MSL1150-L20C	316	267	45	12	B
	25	●	MSL1150-L25C	373	324	45	12	B
11.6	20	□	MSL1160-L20C	327	278	45	12	B
	25	□	MSL1160-L25C	387	338	45	12	B
11.7	20	□	MSL1170-L20C	327	278	45	12	B
	25	□	MSL1170-L25C	387	338	45	12	B
11.8	20	□	MSL1180-L20C	327	278	45	12	B
	25	□	MSL1180-L25C	387	338	45	12	B
11.9	20	□	MSL1190-L20C	327	278	45	12	B
	25	□	MSL1190-L25C	387	338	45	12	B
12.0	20	●	MSL1200-L20C	327	278	45	12	B
	25	●	MSL1200-L25C	387	338	45	12	B
12.1	20	□	MSL1210-L20C	339	290	45	14	B
12.2	20	□	MSL1220-L20C	339	290	45	14	B
12.3	20	□	MSL1230-L20C	339	290	45	14	B
12.4	20	□	MSL1240-L20C	339	290	45	14	B
12.5	20	●	MSL1250-L20C	339	290	45	14	B
12.6	20	□	MSL1260-L20C	350	301	45	14	B
12.7	20	□	MSL1270-L20C	350	301	45	14	B
12.8	20	□	MSL1280-L20C	350	301	45	14	B
12.9	20	□	MSL1290-L20C	350	301	45	14	B
13.0	20	●	MSL1300-L20C	350	301	45	14	B
13.1	20	□	MSL1310-L20C	362	313	45	14	B
13.2	20	□	MSL1320-L20C	362	313	45	14	B
13.3	20	□	MSL1330-L20C	362	313	45	14	B
13.4	20	□	MSL1340-L20C	362	313	45	14	B
13.5	20	●	MSL1350-L20C	362	313	45	14	B
13.6	20	□	MSL1360-L20C	373	324	45	14	B
13.7	20	□	MSL1370-L20C	373	324	45	14	B
13.8	20	□	MSL1380-L20C	373	324	45	14	B
13.9	20	□	MSL1390-L20C	373	324	45	14	B
14.0	20	●	MSL1400-L20C	373	324	45	14	B

- : Stock Standard
- ★ : Stock Standard in Japan.
- : Non stock, produced to order only

● Centripetal top edge geometry

Top edge geometry

Centripetal top edge geometry with the small point angle and X-thinning achieves highly accurate hole positions! ($\theta_1 < \theta_2$)

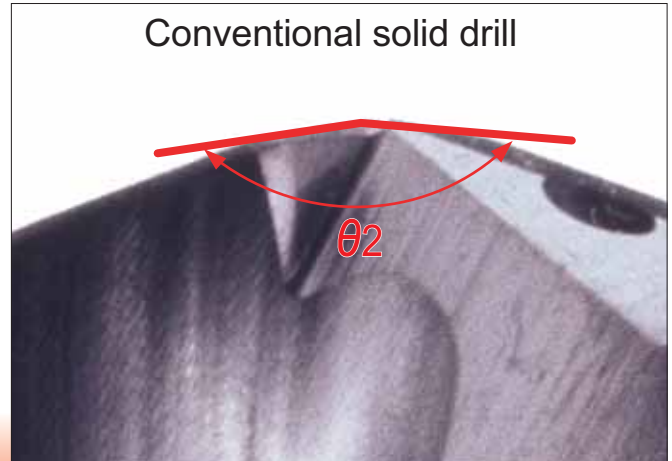
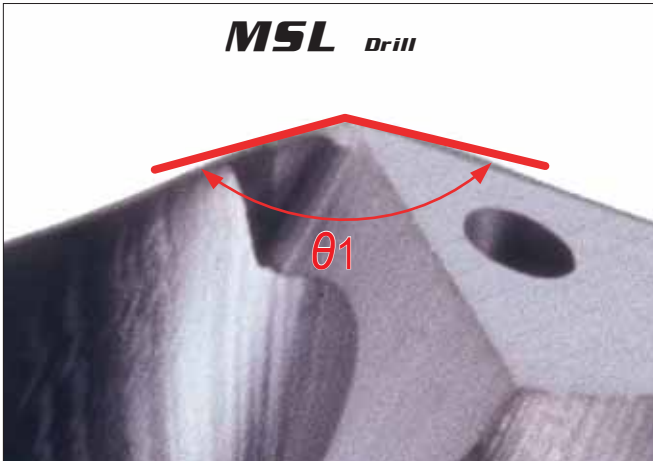

● Machining accuracy (over size)

MSL-Drills are highly wear resistant for maintaining hole size accuracy!

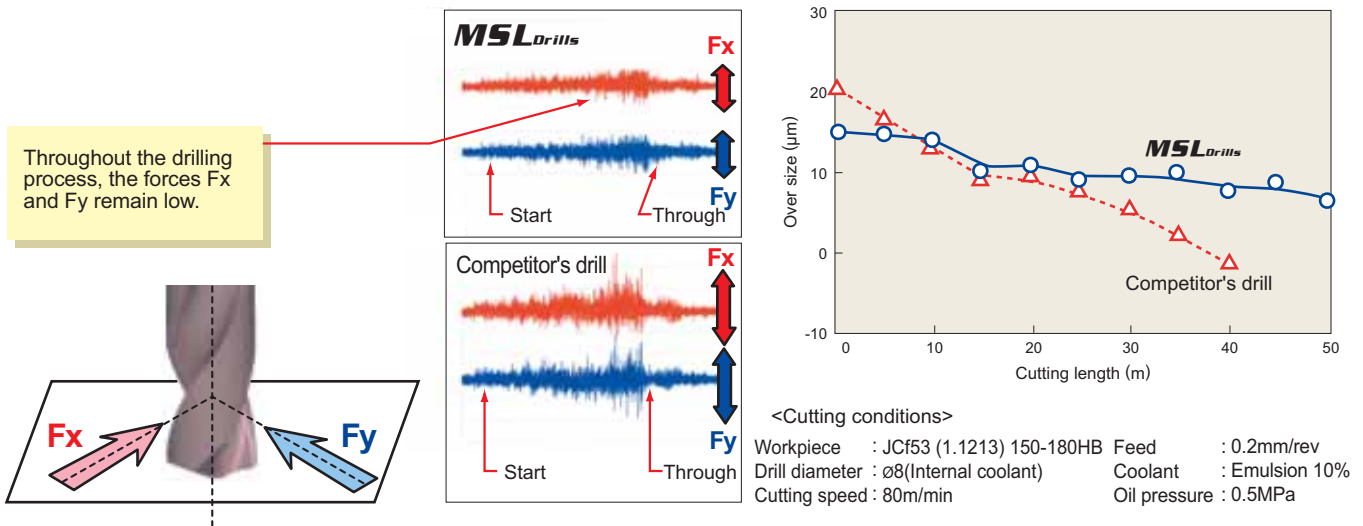

MSL SUPER LONG DRILLS



● Tool life

MSL-Drills are highly flank and margin wear resistant!

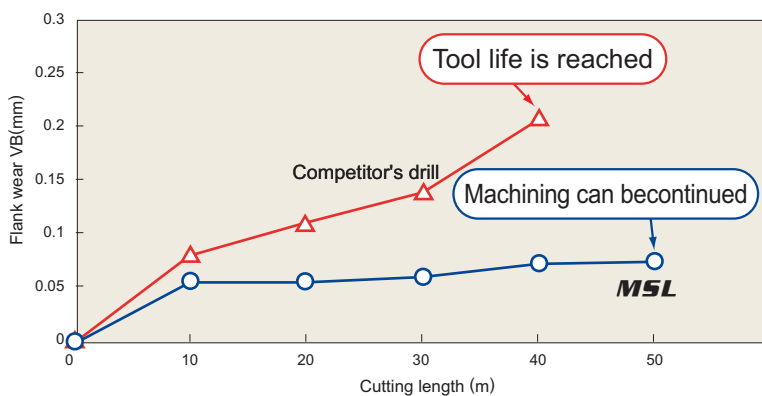

Enlarged picture of the margin after drilling 40m

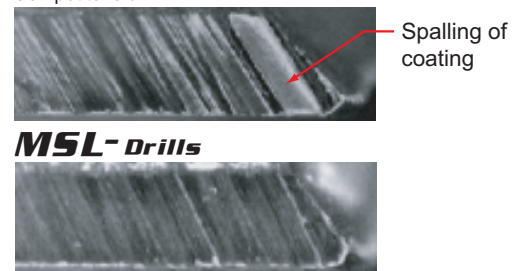

<Cutting conditions>
 Workpiece : Cf53 (1.1213) Cutting speed : 80m/min
 Hardness : 150-180HB Feed : 0.2mm/rev
 Drill diameter : ø8 (Internal coolant) Hole depth : 25mm
 Coolant : Emulsion 10% (Through hole)

RECOMMENDED CUTTING CONDITIONS

MSL DRILL (l/d=20–30)

Work Material	Drill Diameter Conditions Hardness	φ3.0–φ6.0		φ6.0–φ10.0		φ10.0–φ14.0	
		Cutting Speed (m/min)	Feed (mm/rev)	Cutting Speed (m/min)	Feed (mm/rev)	Cutting Speed (m/min)	Feed (mm/rev)
P Mild Steel	≤180HB	85 (35–100)	0.20 (0.15–0.25)	85 (45–120)	0.25 (0.15–0.35)	90 (55–120)	0.30 (0.20–0.35)
	180–280HB	80 (40–95)	0.20 (0.15–0.25)	90 (50–120)	0.25 (0.20–0.35)	90 (60–130)	0.30 (0.15–0.35)
		280–350HB	75 (35–80)	0.15 (0.15–0.20)	80 (45–115)	0.20 (0.15–0.25)	85 (55–115)
M Stainless Steel	≤200HB	50 (20–80)	0.10 (0.05–0.15)	60 (20–90)	0.12 (0.05–0.15)	70 (20–90)	0.15 (0.10–0.20)
K Cast Iron	Tensile Strength ≤350N/mm ²	70 (40–85)	0.25 (0.15–0.30)	75 (50–90)	0.30 (0.20–0.35)	80 (50–95)	0.35 (0.20–0.40)
	Ductile Cast Iron Tensile Strength ≤450N/mm ²	65 (35–80)	0.20 (0.15–0.25)	70 (45–85)	0.25 (0.15–0.30)	75 (45–90)	0.30 (0.20–0.35)
S Heat Resistant Alloy	–	20 (10–25)	0.10 (0.05–0.15)	25 (15–30)	0.12 (0.05–0.15)	25 (15–30)	0.15 (0.10–0.20)

Machining conditions can vary greatly, please use the above tables as a reference starting point only and adjust the values according to the conditions. For drill lengths greater than l/d=10 it is recommended to drill a pilot hole.

HOW TO USE LONG TYPE DRILLS

● Drilling a blind hole

■ 1. Drilling a pilot hole

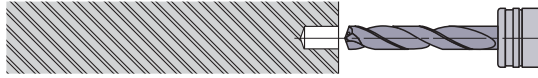

- ① Use a drill with a larger (flatter) point angle than the super long type. Mitsubishi type MPS is recommended.
- ② Ensure a high precision hole is drilled for the guide.
- ③ Drill depth : Approx 1D or deeper.
(Adjust the pilot hole depth according to the length of the super long type.)

■ 2. Initial cutting with the long type drill

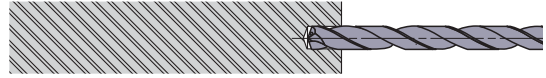

- ① Penetrate the pilot hole at low revolution. (Cutting speed 20–30m/min, feed rate 0.2–0.3mm/rev)
- ② Stop the long type drill 1–3mm short of the pilot hole bottom.

■ 3. Drill the deep hole

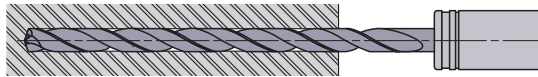

- ① Start cutting at the recommended speed and feed with a non-peck (continuous feed) cycle.

■ 4. Drill retraction

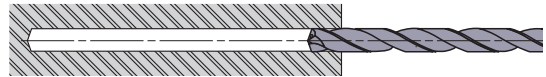

- ① After drilling, lower the cutting revolution about 1–2mm short of the hole end. (Cutting speed of around 20–30m/min)
- ② Retract the drill to the pilot hole depth starting point at a feed rate of 3000mm/min.
- ③ Finally, clear the hole at a cutting speed of 20–30m/min and feed rate of 0.2–0.3mm/rev.

● Drilling and breaking through on irregular faces or angles

■ 1. Spot facing

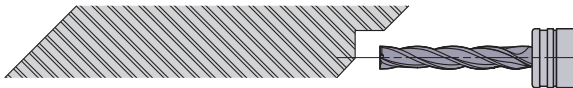

- ① Machine a flat or the irregular face by using an end mill or slot drill capable of spot facing. Make the spot face diameter the same size as the required deep hole diameter.

■ 2. Drilling a pilot hole

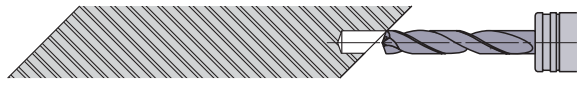

- ① Use a drill with a larger (flatter) point angle than the super long type. Mitsubishi type MPS is recommended.
- ② Ensure a high precision hole is drilled for the guide.
- ③ Drill depth : Approx 1D or deeper.
(Adjust the pilot hole depth according to the length of the super long type.)

■ 3. Initial cutting with the long type drill

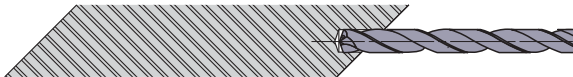

- ① Penetrate the pilot hole at a low revolution. (Cutting speed 20–30m/min, feed rate 0.2–0.3mm/rev)
- ② Stop the long type drill 1–3mm short of the pilot hole bottom.

■ 4. Drill the deep hole

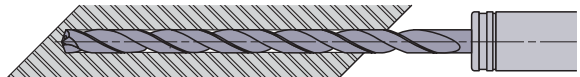

- ① Start cutting at the recommended speed and feed with a non-peck (continuous feed) cycle.

■ 5. Breaking through

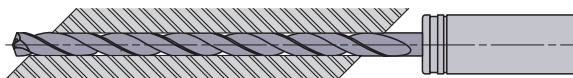

- ① When breaking through, the cutting edge can be damaged.
- ② A feed rate of 0.05–0.1mm/rev is recommended.

■ 6. Drill retraction

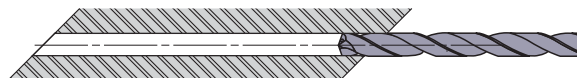

- ① Retract the drill to the pilot hole depth starting point at a feed rate of 3000mm/min.
- ② Finally clear the hole at a cutting speed of 20–30m/min and feed rate of 0.2–0.3mm/rev.



MGS

High precision Solid Carbide Micro gun drills.
Excellent runout accuracy ensures stable
drilling on general-purpose machines.



PRECISION
FOR SUCCESS

CHOOSE JAPAN'S NO. 1

MITSUBISHI
MITSUBISHI MATERIALS

www.mitsubishicarbide.com

MICRO-MGS



Features

Solid carbide with through coolant holes for high precision drilling

Smooth rake face & sharp cutting edge

Driver available for use on gun drill machines

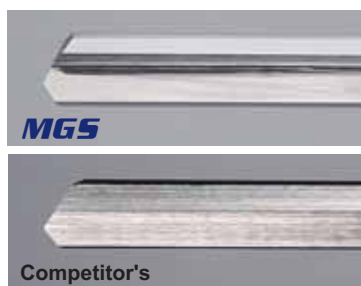

High precision carbide shank suitable for use with collets and shrink fit holders

VP, GP or UP coated carbide is available (produced to order only)

How to Use

1. Pilot hole drilling.
(Mitsubishi's MPS, MWE or MWS is recommended.)

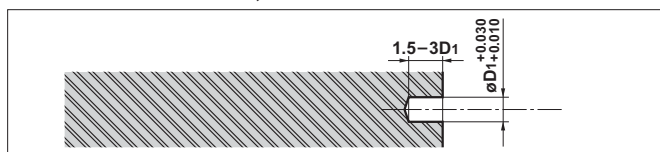

2. Drill is inserted into the pilot hole without being rotated.

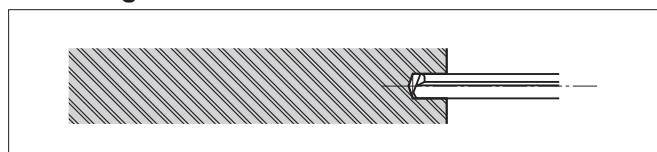

3. Turn the coolant on, raise cutting speed and feed to the recommended cutting condition, and commence drilling.

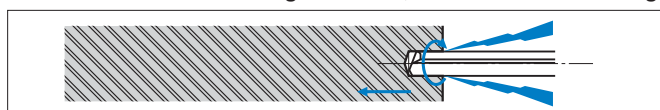

4. Return to "Pos 2" after drilling, turn the coolant off, and stop the drill rotating.

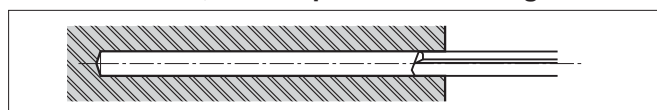

Application Examples

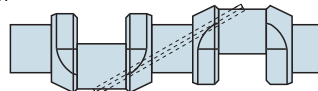
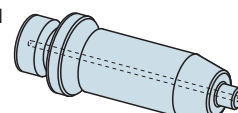
Tool		MGS0150L100B	MGS0150L080B
Grade		HTi10	HTi10
Machine Type		Turret type turning mill	Turret type turning mill
Component		Machine part	Fuel injection nozzle
Workpiece		Cast Iron 	Stainless Steel 
Cutting Conditions	Cutting Speed (m/min)	28.3	28.3
	Feed (mm/rev)	0.003	0.003
	Revolution (min ⁻¹)	6000	6000
	Feed Rate (mm/min)	18	18
	Hole Depth (mm)	65 (L/D=43D)	45 (L/D=30D)
Coolant		W.S.O. : 7MPa	W.S.O. : 7MPa

DRILLING (MICRO SOLID CARBIDE GUN DRILL)

MICRO-MGS

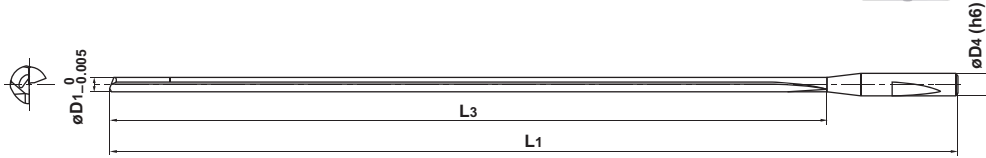

MGS type can be used with shrink fit holders.

Drill Dia. D ₁ (mm)	Coolant	Stock HTT10	Order Number	Dimensions (mm)		
				L ₃	L ₁	D ₄
0.7	Int.	★	MGS0070L040B	40	80	3
	Int.	★	0070L060B	60	100	3
0.8	Int.	★	0080L040B	40	80	3
	Int.	★	0080L060B	60	100	3
0.9	Int.	★	0090L040B	40	80	3
	Int.	★	0090L060B	60	100	3
1.0	Int.	★	0100L040B	40	80	3
	Int.	★	0100L060B	60	100	3
	Int.	★	0100L080B	80	120	3
1.1	Int.	★	0110L040B	40	80	3
	Int.	★	0110L060B	60	100	3
	Int.	★	0110L080B	80	120	3
1.2	Int.	★	0120L040B	40	80	3
	Int.	★	0120L060B	60	100	3
	Int.	★	0120L080B	80	120	3
1.3	Int.	★	0130L060B	60	100	3
	Int.	★	0130L080B	80	120	3
	Int.	★	0130L100B	100	140	3
1.4	Int.	★	0140L060B	60	100	3
	Int.	★	0140L080B	80	120	3
	Int.	★	0140L100B	100	140	3
1.5	Int.	★	0150L060B	60	100	3
	Int.	★	0150L080B	80	120	3
	Int.	★	0150L100B	100	140	3
1.6	Int.	★	0160L060B	60	100	3
	Int.	★	0160L080B	80	120	3
	Int.	★	0160L100B	100	140	3
1.7	Int.	★	0170L060B	60	100	3
	Int.	★	0170L080B	80	120	3
	Int.	★	0170L100B	100	140	3

Drill Dia. D ₁ (mm)	Coolant	Stock HTT10	Order Number	Dimensions (mm)		
				L ₃	L ₁	D ₄
1.8	Int.	★	MGS0180L060B	60	100	3
	Int.	★	0180L080B	80	120	3
1.9	Int.	★	0180L100B	100	140	3
	Int.	★	0190L060B	60	100	3
	Int.	★	0190L080B	80	120	3
2.0	Int.	★	0190L100B	100	140	3
	Int.	★	0200L060B	60	100	3
	Int.	★	0200L080B	80	120	3
2.1	Int.	★	0200L100B	100	140	3
	Int.	★	0210L080B	80	120	3
	Int.	★	0210L100B	100	140	3
2.2	Int.	★	0220L080B	80	120	3
	Int.	★	0220L100B	100	140	3
2.3	Int.	★	0230L080B	80	120	3
	Int.	★	0230L100B	100	140	3
2.4	Int.	★	0240L080B	80	120	3
	Int.	★	0240L100B	100	140	3
2.5	Int.	★	0250L080B	80	120	3
	Int.	★	0250L100B	100	140	3
2.6	Int.	★	0260L080B	80	120	3
	Int.	★	0260L100B	100	140	3
2.7	Int.	★	0270L080B	80	120	3
	Int.	★	0270L100B	100	140	3
2.8	Int.	★	0280L080B	80	120	3
	Int.	★	0280L100B	100	140	3
2.9	Int.	★	0290L080B	80	120	3
	Int.	★	0290L100B	100	140	3
3.0	Int.	★	0300L080B	80	120	3
	Int.	★	0300L100B	100	140	3

Note) Contact Mitsubishi Materials regarding coated products (VP, GP and UP coated carbide).

Driver

Order Number	Dimensions (mm)					Set Screw	Wrench
	D ₄	D ₈	L ₁	L ₃	L ₄		
MGD38	12.7	3.0	38.1	12.6	12.7	HSS04004	HKY20F
MGD70	12.7	3.0	70.0	25.0	20.0	HSS04004	HKY20F

When Using with a Driver

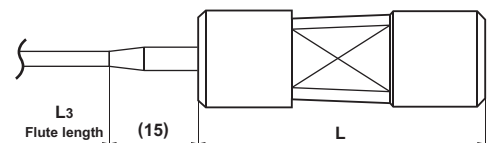

- : Stock Standard
- ★ : Stock Standard in Japan.
- : Non stock, produced to order only

RECOMMENDED CUTTING CONDITIONS

Work Material	Drill Diameter	$\phi 0.7 - \phi 3.0$		Recommended Coolant
	Conditions	Cutting Speed (m/min)	Feed (mm/rev)	
	Hardness			
P Mild Steel	$\leq 180\text{HB}$	70	-0.001	Water insoluble
	180-280HB	60	-0.007	
	280-350HB	40	-0.005	
M Stainless Steel	$\leq 200\text{HB}$	40	-0.005	Water insoluble
K Cast Iron	Tensile Strength $\leq 350\text{MPa}$	70	-0.02	Water insoluble
	Ductile Cast Iron Tensile Strength $\leq 450\text{MPa}$	50	-0.015	Water Soluble Oil
N Aluminium Alloy	-	110	-0.02	Water Soluble Oil
	Copper Alloy	-	70	

Special Application Notes :

- A pilot hole or guide bushing is required.
- Coolant filter must be less than 5 microns.
Fine filtration is necessary to prevent blockage of the coolant holes.
- High pressure coolant is required. At least 10MPa.
(If the pressure is too low, chip blockage can occur.)



MNS

MNS drill series for machining of aluminium alloys!
High feed & high efficiency drilling with feed
rates up to 10000mm/min.



PRECISION
FOR SUCCESS

CHOOSE JAPAN'S NO. 1

MITSUBISHI
MITSUBISHI MATERIALS

www.mitsubishicarbide.com

Solid Carbide Drill for High Efficiency Machining of Aluminium Alloys

MNS

Features

- Optimum flute & cutting edge geometry for machining of aluminium alloy

Cutting edge shape

Wavy cutting edge

The wave edge design achieves a sharp peripheral edge cutting performance with a strong initial cutting point near the centre.

Cross sectional shape

(Cutting edge shoulder cross section)

Flutes of top edge

The small R geometry generates initial curling of the chips and combines with the larger geometry to promote smooth chip evacuation.

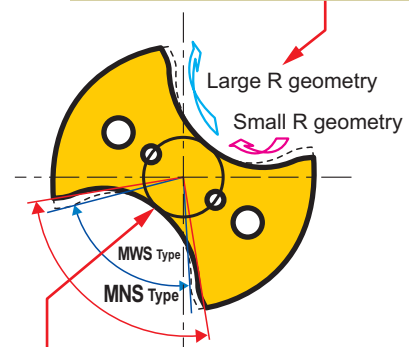
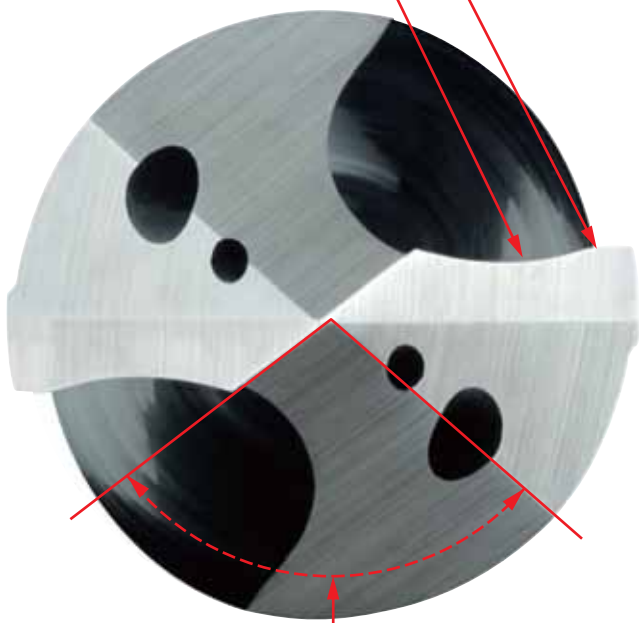

Special flute geometry

The wide flute is optimally designed for machining of aluminium alloy.

(Mid flute cross section)

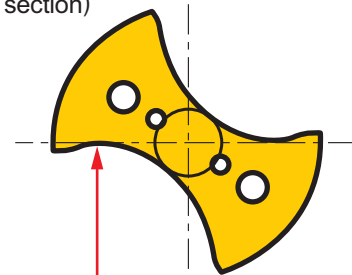

Flute geometry

Large flute to prevent chip jamming.

PAT. pending

Web thinning pocket

Large thinning pocket for smooth evacuation of the chips prevents welding of the cutting edge.

- Computerized flow simulation was used to determine the best positioning of the coolant holes

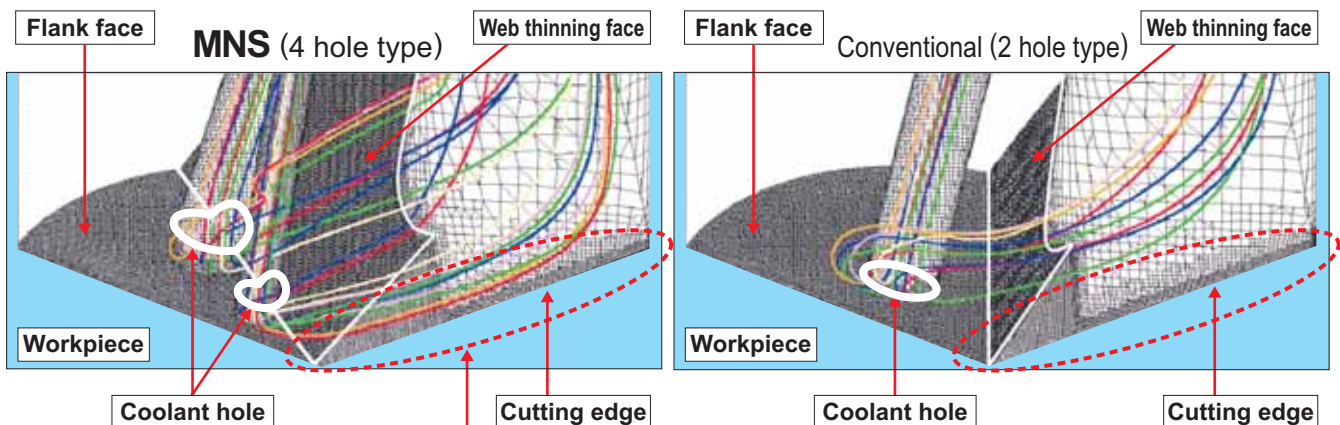

- Effective lubrication for the cutting edge point and rake face that are usually prone to welding

DRILLING (SOLID CARBIDE)

MNS



P	M	K	S	N	H
---	---	---	---	---	----------

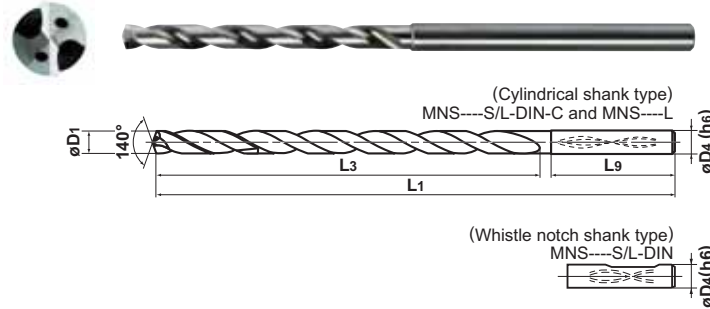

■ MNS○○○○S/L-DIN, MNS○○○○S/L-DIN-C Type

D1	3.0<D1≤6.0	6.0<D1≤10.0	10.0<D1≤18.0	18.0<D1≤20.0
Tolerance	+0.016 +0.004	+0.021 +0.006	+0.025 +0.007	+0.029 +0.008

■ MNS○○○○-LOC, MNS○○○○-LOC Type

D1	D1≤3.0	3.0<D1≤6.0	6.0<D1≤10.0	10.0<D1≤18.0	18.0<D1≤20.0
Tolerance	0 -0.014	0 -0.018	0 -0.022	0 -0.027	0 -0.033

(Note 1) 4.5 or smaller diameter drills are designed with 2 coolant holes.
 (Note 2) MNS type can be used for shrink fit holders.

Drill Dia. D1 (mm)	Hole Depth (l/d)	Coolant (Int./Ext.)	Stock TF15	Order Number	Dimensions (mm)			
					L1	L3	L9	D4
3.0	3	Int.	□	MNS0300S-DIN	62	20	36	6
	3	Int.	□	0300S-DIN-C	62	20	36	6
	5	Int.	□	0300L-DIN	66	28	36	6
	5	Int.	●	0300L-DIN-C	66	28	36	6
	8	Int.	□	0300-L8C	74	34	36	6
	10	Int.	□	0300-L10C	80	40	36	6
	12	Int.	●	0300-L12C	86	46	36	6
	15	Int.	□	0300-L15C	95	55	36	6
	20	Int.	●	0300-L20C	110	70	36	6
	25	Int.	□	0300-L25C	125	85	36	6
30	Int.	●	0300-L30C	140	100	36	6	
3.1	3	Int.	□	0310S-DIN	62	20	36	6
	3	Int.	□	0310S-DIN-C	62	20	36	6
	5	Int.	□	0310L-DIN	66	28	36	6
	5	Int.	□	0310L-DIN-C	66	28	36	6
	8	Int.	□	0310-L8C	80	40	36	6
	10	Int.	□	0310-L10C	87	47	36	6
	12	Int.	□	0310-L12C	94	54	36	6
	15	Int.	□	0310-L15C	104	64	36	6
	20	Int.	□	0310-L20C	122	82	36	6
	25	Int.	□	0310-L25C	139	99	36	6
30	Int.	□	0310-L30C	157	117	36	6	
3.2	3	Int.	□	0320S-DIN	62	20	36	6
	3	Int.	□	0320S-DIN-C	62	20	36	6
	5	Int.	□	0320L-DIN	66	28	36	6
	5	Int.	●	0320L-DIN-C	66	28	36	6
	8	Int.	□	0320-L8C	80	40	36	6
	10	Int.	□	0320-L10C	87	47	36	6
	12	Int.	●	0320-L12C	94	54	36	6
	15	Int.	□	0320-L15C	104	64	36	6
	20	Int.	●	0320-L20C	122	82	36	6
	25	Int.	□	0320-L25C	139	99	36	6
30	Int.	●	0320-L30C	157	117	36	6	

Drill Dia. D1 (mm)	Hole Depth (l/d)	Coolant (Int./Ext.)	Stock TF15	Order Number	Dimensions (mm)			
					L1	L3	L9	D4
3.3	3	Int.	□	MNS0330S-DIN	62	20	36	6
	3	Int.	□	0330S-DIN-C	62	20	36	6
	5	Int.	□	0330L-DIN	66	28	36	6
	5	Int.	●	0330L-DIN-C	66	28	36	6
	8	Int.	□	0330-L8C	80	40	36	6
	10	Int.	□	0330-L10C	87	47	36	6
	12	Int.	●	0330-L12C	94	54	36	6
	15	Int.	□	0330-L15C	104	64	36	6
	20	Int.	●	0330-L20C	122	82	36	6
	25	Int.	□	0330-L25C	139	99	36	6
30	Int.	●	0330-L30C	157	117	36	6	
3.4	3	Int.	□	0340S-DIN	62	20	36	6
	3	Int.	□	0340S-DIN-C	62	20	36	6
	5	Int.	□	0340L-DIN	66	28	36	6
	5	Int.	□	0340L-DIN-C	66	28	36	6
	8	Int.	□	0340-L8C	80	40	36	6
	10	Int.	□	0340-L10C	87	47	36	6
	12	Int.	□	0340-L12C	94	54	36	6
	15	Int.	□	0340-L15C	104	64	36	6
	20	Int.	□	0340-L20C	122	82	36	6
	25	Int.	□	0340-L25C	139	99	36	6
30	Int.	□	0340-L30C	157	117	36	6	
3.5	3	Int.	□	0350S-DIN	62	20	36	6
	3	Int.	□	0350S-DIN-C	62	20	36	6
	5	Int.	□	0350L-DIN	66	28	36	6
	5	Int.	●	0350L-DIN-C	66	28	36	6
	8	Int.	□	0350-L8C	80	40	36	6
	10	Int.	□	0350-L10C	87	47	36	6
	12	Int.	●	0350-L12C	94	54	36	6
	15	Int.	□	0350-L15C	104	64	36	6
	20	Int.	●	0350-L20C	122	82	36	6
	25	Int.	□	0350-L25C	139	99	36	6
30	Int.	●	0350-L30C	157	117	36	6	

(Note) Please contact your Mitsubishi Materials partner for any geometry that is not in the brochure.

DRILLING | MNS DRILLS

Ø 3.0 ~ 3.5

- : Stock Standard
- ★ : Stock Standard in Japan.
- : Non stock, produced to order only

Drill Dia. D1 (mm)	Hole Depth (l/d)	Coolant (Int./Ext.)	Stock TF15	Order Number	Dimensions (mm)			
					L1	L3	L9	D4
3.6	3	Int.	□	MNS0360S-DIN	62	20	36	6
	3	Int.	□	0360S-DIN-C	62	20	36	6
	5	Int.	□	0360L-DIN	66	28	36	6
	5	Int.	□	0360L-DIN-C	66	28	36	6
	8	Int.	□	0360-L8C	85	45	36	6
	10	Int.	□	0360-L10C	93	53	36	6
	12	Int.	□	0360-L12C	101	61	36	6
	15	Int.	□	0360-L15C	113	73	36	6
	20	Int.	□	0360-L20C	133	93	36	6
	25	Int.	□	0360-L25C	153	113	36	6
30	Int.	□	0360-L30C	173	133	36	6	
3.7	3	Int.	□	0370S-DIN	62	20	36	6
	3	Int.	□	0370S-DIN-C	62	20	36	6
	5	Int.	□	0370L-DIN	66	28	36	6
	5	Int.	□	0370L-DIN-C	66	28	36	6
	8	Int.	□	0370-L8C	85	45	36	6
	10	Int.	□	0370-L10C	93	53	36	6
	12	Int.	□	0370-L12C	101	61	36	6
	15	Int.	□	0370-L15C	113	73	36	6
	20	Int.	□	0370-L20C	133	93	36	6
	25	Int.	□	0370-L25C	153	113	36	6
30	Int.	□	0370-L30C	173	133	36	6	
3.8	3	Int.	□	0380S-DIN	66	24	36	6
	3	Int.	□	0380S-DIN-C	66	24	36	6
	5	Int.	□	0380L-DIN	74	36	36	6
	5	Int.	□	0380L-DIN-C	74	36	36	6
	8	Int.	□	0380-L8C	85	45	36	6
	10	Int.	□	0380-L10C	93	53	36	6
	12	Int.	□	0380-L12C	101	61	36	6
	15	Int.	□	0380-L15C	113	73	36	6
	20	Int.	□	0380-L20C	133	93	36	6
	25	Int.	□	0380-L25C	153	113	36	6
30	Int.	□	0380-L30C	173	133	36	6	
3.9	3	Int.	□	0390S-DIN	66	24	36	6
	3	Int.	□	0390S-DIN-C	66	24	36	6
	5	Int.	□	0390L-DIN	74	36	36	6
	5	Int.	□	0390L-DIN-C	74	36	36	6
	8	Int.	□	0390-L8C	85	45	36	6
	10	Int.	□	0390-L10C	93	53	36	6
	12	Int.	□	0390-L12C	101	61	36	6
	15	Int.	□	0390-L15C	113	73	36	6
	20	Int.	□	0390-L20C	133	93	36	6
	25	Int.	□	0390-L25C	153	113	36	6
30	Int.	□	0390-L30C	173	133	36	6	
4.0	3	Int.	□	0400S-DIN	66	24	36	6
	3	Int.	□	0400S-DIN-C	66	24	36	6
	5	Int.	□	0400L-DIN	74	36	36	6
	5	Int.	●	0400L-DIN-C	74	36	36	6
	8	Int.	□	0400-L8C	85	45	36	6
	10	Int.	□	0400-L10C	93	53	36	6
	12	Int.	●	0400-L12C	101	61	36	6
	15	Int.	□	0400-L15C	113	73	36	6
	20	Int.	●	0400-L20C	133	93	36	6
	25	Int.	□	0400-L25C	153	113	36	6
30	Int.	●	0400-L30C	173	133	36	6	

Drill Dia. D1 (mm)	Hole Depth (l/d)	Coolant (Int./Ext.)	Stock TF15	Order Number	Dimensions (mm)			
					L1	L3	L9	D4
4.1	3	Int.	□	MNS0410S-DIN	66	24	36	6
	3	Int.	□	0410S-DIN-C	66	24	36	6
	5	Int.	□	0410L-DIN	74	36	36	6
	5	Int.	□	0410L-DIN-C	74	36	36	6
	8	Int.	□	0410-L8C	91	51	36	6
	10	Int.	□	0410-L10C	100	60	36	6
	12	Int.	□	0410-L12C	109	69	36	6
	15	Int.	□	0410-L15C	122	82	36	6
	20	Int.	□	0410-L20C	145	105	36	6
	25	Int.	□	0410-L25C	167	127	36	6
30	Int.	□	0410-L30C	190	150	36	6	
4.2	3	Int.	□	0420S-DIN	66	24	36	6
	3	Int.	□	0420S-DIN-C	66	24	36	6
	5	Int.	□	0420L-DIN	74	36	36	6
	5	Int.	●	0420L-DIN-C	74	36	36	6
	8	Int.	□	0420-L8C	91	51	36	6
	10	Int.	□	0420-L10C	100	60	36	6
	12	Int.	●	0420-L12C	109	69	36	6
	15	Int.	□	0420-L15C	122	82	36	6
	20	Int.	●	0420-L20C	145	105	36	6
	25	Int.	□	0420-L25C	167	127	36	6
30	Int.	●	0420-L30C	190	150	36	6	
4.3	3	Int.	□	0430S-DIN	66	24	36	6
	3	Int.	□	0430S-DIN-C	66	24	36	6
	5	Int.	□	0430L-DIN	74	36	36	6
	5	Int.	□	0430L-DIN-C	74	36	36	6
	8	Int.	□	0430-L8C	91	51	36	6
	10	Int.	□	0430-L10C	100	60	36	6
	12	Int.	□	0430-L12C	109	69	36	6
	15	Int.	□	0430-L15C	122	82	36	6
	20	Int.	□	0430-L20C	145	105	36	6
	25	Int.	□	0430-L25C	167	127	36	6
30	Int.	□	0430-L30C	190	150	36	6	
4.4	3	Int.	□	0440S-DIN	66	24	36	6
	3	Int.	□	0440S-DIN-C	66	24	36	6
	5	Int.	□	0440L-DIN	74	36	36	6
	5	Int.	□	0440L-DIN-C	74	36	36	6
	8	Int.	□	0440-L8C	91	51	36	6
	10	Int.	□	0440-L10C	100	60	36	6
	12	Int.	□	0440-L12C	109	69	36	6
	15	Int.	□	0440-L15C	122	82	36	6
	20	Int.	□	0440-L20C	145	105	36	6
	25	Int.	□	0440-L25C	167	127	36	6
30	Int.	□	0440-L30C	190	150	36	6	
4.5	3	Int.	□	0450S-DIN	66	24	36	6
	3	Int.	□	0450S-DIN-C	66	24	36	6
	5	Int.	□	0450L-DIN	74	36	36	6
	5	Int.	□	0450L-DIN-C	74	36	36	6
	8	Int.	□	0450-L8C	91	51	36	6
	10	Int.	□	0450-L10C	100	60	36	6
	12	Int.	□	0450-L12C	109	69	36	6
	15	Int.	□	0450-L15C	122	82	36	6
	20	Int.	□	0450-L20C	145	105	36	6
	25	Int.	□	0450-L25C	167	127	36	6
30	Int.	□	0450-L30C	190	150	36	6	

MNS DRILLS



DRILLING (SOLID CARBIDE)

MNS



P **M** **K** **S** **N** **H**

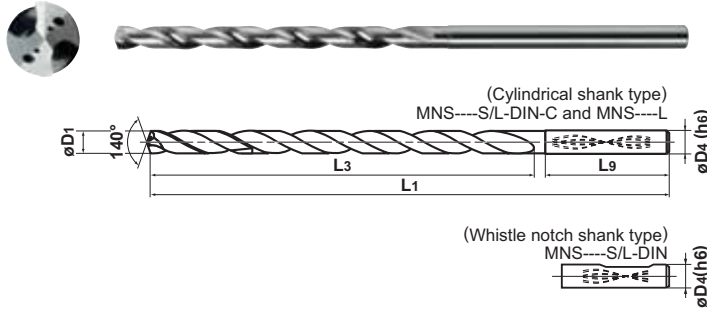

■ MNS○○○○S/L-DIN, MNS○○○○S/L-DIN-C Type

D1	3.0<D1≤6.0	6.0<D1≤10.0	10.0<D1≤18.0	18.0<D1≤20.0
Tolerance	+0.016 +0.004	+0.021 +0.006	+0.025 +0.007	+0.029 +0.008

■ MNS○○○○-L○C, MNS○○○○-L○C Type

D1	D1≤3.0	3.0<D1≤6.0	6.0<D1≤10.0	10.0<D1≤18.0	18.0<D1≤20.0
Tolerance	0 -0.014	0 -0.018	0 -0.022	0 -0.027	0 -0.033

(Note) MNS type can be used for shrink fit holders.

Drill Dia. D1 (mm)	Hole Depth (l/d)	Coolant (Int./Ext.)	Stock TF15	Order Number	Dimensions (mm)			
					L1	L3	L9	D4
4.6	3	Int.	□	MNS0460S-DIN	66	24	36	6
	3	Int.	□	0460S-DIN-C	66	24	36	6
	5	Int.	□	0460L-DIN	74	36	36	6
	5	Int.	□	0460L-DIN-C	74	36	36	6
	8	Int.	□	0460-L8C	96	55	36	6
	10	Int.	□	0460-L10C	106	66	36	6
	12	Int.	□	0460-L12C	116	76	36	6
	15	Int.	□	0460-L15C	131	91	36	6
	20	Int.	□	0460-L20C	156	116	36	6
	25	Int.	□	0460-L25C	181	141	36	6
4.65	3	Int.	□	0465S-DIN	66	24	36	6
	3	Int.	□	0465S-DIN-C	66	24	36	6
	5	Int.	□	0465L-DIN	74	36	36	6
	5	Int.	□	0465L-DIN-C	74	36	36	6
4.7	3	Int.	□	0470S-DIN	66	24	36	6
	3	Int.	□	0470S-DIN-C	66	24	36	6
	5	Int.	□	0470L-DIN	74	36	36	6
	5	Int.	□	0470L-DIN-C	74	36	36	6
	8	Int.	□	0470-L8C	96	55	36	6
	10	Int.	□	0470-L10C	106	66	36	6
	12	Int.	□	0470-L12C	116	76	36	6
	15	Int.	□	0470-L15C	131	91	36	6
	20	Int.	□	0470-L20C	156	116	36	6
	25	Int.	□	0470-L25C	181	141	36	6
4.8	3	Int.	□	0480S-DIN	66	28	36	6
	3	Int.	□	0480S-DIN-C	66	28	36	6
	5	Int.	□	0480L-DIN	82	44	36	6
	5	Int.	□	0480L-DIN-C	82	44	36	6
	8	Int.	□	0480-L8C	96	55	36	6
	10	Int.	□	0480-L10C	106	66	36	6
	12	Int.	□	0480-L12C	116	76	36	6
	15	Int.	□	0480-L15C	131	91	36	6
	20	Int.	□	0480-L20C	156	116	36	6
	25	Int.	□	0480-L25C	181	141	36	6

Drill Dia. D1 (mm)	Hole Depth (l/d)	Coolant (Int./Ext.)	Stock TF15	Order Number	Dimensions (mm)			
					L1	L3	L9	D4
4.9	3	Int.	□	MNS0490S-DIN	66	28	36	6
	3	Int.	□	0490S-DIN-C	66	28	36	6
	5	Int.	□	0490L-DIN	82	44	36	6
	5	Int.	□	0490L-DIN-C	82	44	36	6
	8	Int.	□	0490-L8C	96	55	36	6
	10	Int.	□	0490-L10C	106	66	36	6
	12	Int.	□	0490-L12C	116	76	36	6
	15	Int.	□	0490-L15C	131	91	36	6
	20	Int.	□	0490-L20C	156	116	36	6
	25	Int.	□	0490-L25C	181	141	36	6
5.0	3	Int.	□	0500S-DIN	66	28	36	6
	3	Int.	□	0500S-DIN-C	66	28	36	6
	5	Int.	□	0500L-DIN	82	44	36	6
	5	Int.	●	0500L-DIN-C	82	44	36	6
	8	Int.	□	0500-L8C	96	55	36	6
	10	Int.	□	0500-L10C	106	66	36	6
	12	Int.	●	0500-L12C	116	76	36	6
	15	Int.	□	0500-L15C	131	91	36	6
	20	Int.	●	0500-L20C	156	116	36	6
	25	Int.	□	0500-L25C	181	141	36	6
5.1	3	Int.	□	0510S-DIN	66	28	36	6
	3	Int.	□	0510S-DIN-C	66	28	36	6
	5	Int.	□	0510L-DIN	82	44	36	6
	5	Int.	●	0510L-DIN-C	82	44	36	6
	8	Int.	□	0510-L8C	102	62	36	6
	10	Int.	□	0510-L10C	113	73	36	6
	12	Int.	□	0510-L12C	124	84	36	6
	15	Int.	□	0510-L15C	140	100	36	6
	20	Int.	□	0510-L20C	168	128	36	6
	25	Int.	□	0510-L25C	195	155	36	6

(Note) Please contact Mitsubishi Carbide for any geometry that is not in the brochure (e.g. different diameter and length).

● : Stock Standard
 ★ : Stock Standard in Japan.
 □ : Non stock, produced to order only

Drill Dia. D1 (mm)	Hole Depth (l/d)	Coolant (Int./Ext.)	Stock TF15	Order Number	Dimensions (mm)			
					L1	L3	L9	D4
5.2	3	Int.	□	MNS0520S-DIN	66	28	36	6
	3	Int.	□	0520S-DIN-C	66	28	36	6
	5	Int.	□	0520L-DIN	82	44	36	6
	5	Int.	□	0520L-DIN-C	82	44	36	6
	8	Int.	□	0520-L8C	102	62	36	6
	10	Int.	□	0520-L10C	113	73	36	6
	12	Int.	□	0520-L12C	124	84	36	6
	15	Int.	□	0520-L15C	140	100	36	6
	20	Int.	□	0520-L20C	168	128	36	6
	25	Int.	□	0520-L25C	195	155	36	6
30	Int.	□	0520-L30C	223	183	36	6	
5.3	3	Int.	□	0530S-DIN	66	28	36	6
	3	Int.	□	0530S-DIN-C	66	28	36	6
	5	Int.	□	0530L-DIN	82	44	36	6
	5	Int.	□	0530L-DIN-C	82	44	36	6
	8	Int.	□	0530-L8C	102	62	36	6
	10	Int.	□	0530-L10C	113	73	36	6
	12	Int.	□	0530-L12C	124	84	36	6
	15	Int.	□	0530-L15C	140	100	36	6
	20	Int.	□	0530-L20C	168	128	36	6
	25	Int.	□	0530-L25C	195	155	36	6
30	Int.	□	0530-L30C	223	183	36	6	
5.4	3	Int.	□	0540S-DIN	66	28	36	6
	3	Int.	□	0540S-DIN-C	66	28	36	6
	5	Int.	□	0540L-DIN	82	44	36	6
	5	Int.	□	0540L-DIN-C	82	44	36	6
	8	Int.	□	0540-L8C	102	62	36	6
	10	Int.	□	0540-L10C	113	73	36	6
	12	Int.	□	0540-L12C	124	84	36	6
	15	Int.	□	0540-L15C	140	100	36	6
	20	Int.	□	0540-L20C	168	128	36	6
	25	Int.	□	0540-L25C	195	155	36	6
30	Int.	□	0540-L30C	223	183	36	6	
5.5	3	Int.	□	0550S-DIN	66	28	36	6
	3	Int.	□	0550S-DIN-C	66	28	36	6
	5	Int.	□	0550L-DIN	82	44	36	6
	5	Int.	●	0550L-DIN-C	82	44	36	6
	8	Int.	□	0550-L8C	102	62	36	6
	10	Int.	□	0550-L10C	113	73	36	6
	12	Int.	●	0550-L12C	124	84	36	6
	15	Int.	□	0550-L15C	140	100	36	6
	20	Int.	●	0550-L20C	168	128	36	6
	25	Int.	□	0550-L25C	195	155	36	6
30	Int.	●	0550-L30C	223	183	36	6	
5.55	3	Int.	□	0555S-DIN	66	28	36	6
	3	Int.	□	0555S-DIN-C	66	28	36	6
	5	Int.	□	0555L-DIN	82	44	36	6
	5	Int.	●	0555L-DIN-C	82	44	36	6
5.6	3	Int.	□	0560S-DIN	66	28	36	6
	3	Int.	□	0560S-DIN-C	66	28	36	6
	5	Int.	□	0560L-DIN	82	44	36	6
	5	Int.	□	0560L-DIN-C	82	44	36	6
	8	Int.	□	0560-L8C	107	67	36	6
	10	Int.	□	0560-L10C	119	79	36	6
	12	Int.	□	0560-L12C	131	91	36	6
	15	Int.	□	0560-L15C	149	109	36	6
	20	Int.	□	0560-L20C	179	139	36	6

Drill Dia. D1 (mm)	Hole Depth (l/d)	Coolant (Int./Ext.)	Stock TF15	Order Number	Dimensions (mm)			
					L1	L3	L9	D4
5.6	25	Int.	□	MNS0560-L25C	209	169	36	6
	30	Int.	□	0560-L30C	239	199	36	6
5.7	3	Int.	□	0570S-DIN	66	28	36	6
	3	Int.	□	0570S-DIN-C	66	28	36	6
	5	Int.	□	0570L-DIN	82	44	36	6
	5	Int.	□	0570L-DIN-C	82	44	36	6
	8	Int.	□	0570-L8C	107	67	36	6
	10	Int.	□	0570-L10C	119	79	36	6
	12	Int.	□	0570-L12C	131	91	36	6
	15	Int.	□	0570-L15C	149	109	36	6
	20	Int.	□	0570-L20C	179	139	36	6
	25	Int.	□	0570-L25C	209	169	36	6
30	Int.	□	0570-L30C	239	199	36	6	
5.8	3	Int.	□	0580S-DIN	66	28	36	6
	3	Int.	□	0580S-DIN-C	66	28	36	6
	5	Int.	□	0580L-DIN	82	44	36	6
	5	Int.	□	0580L-DIN-C	82	44	36	6
	8	Int.	□	0580-L8C	107	67	36	6
	10	Int.	□	0580-L10C	119	79	36	6
	12	Int.	□	0580-L12C	131	91	36	6
	15	Int.	□	0580-L15C	149	109	36	6
	20	Int.	□	0580-L20C	179	139	36	6
	25	Int.	□	0580-L25C	209	169	36	6
30	Int.	□	0580-L30C	239	199	36	6	
5.9	3	Int.	□	0590S-DIN	66	28	36	6
	3	Int.	□	0590S-DIN-C	66	28	36	6
	5	Int.	□	0590L-DIN	82	44	36	6
	5	Int.	□	0590L-DIN-C	82	44	36	6
	8	Int.	□	0590-L8C	107	67	36	6
	10	Int.	□	0590-L10C	119	79	36	6
	12	Int.	□	0590-L12C	131	91	36	6
	15	Int.	□	0590-L15C	149	109	36	6
	20	Int.	□	0590-L20C	179	139	36	6
	25	Int.	□	0590-L25C	209	169	36	6
30	Int.	□	0590-L30C	239	199	36	6	
6.0	3	Int.	□	0600S-DIN	66	28	36	6
	3	Int.	□	0600S-DIN-C	66	28	36	6
	5	Int.	□	0600L-DIN	82	44	36	6
	5	Int.	●	0600L-DIN-C	82	44	36	6
	8	Int.	□	0600-L8C	107	67	36	6
	10	Int.	□	0600-L10C	119	79	36	6
	12	Int.	●	0600-L12C	131	91	36	6
	15	Int.	□	0600-L15C	149	109	36	6
	20	Int.	●	0600-L20C	179	139	36	6
	25	Int.	□	0600-L25C	209	169	36	6
30	Int.	●	0600-L30C	239	199	36	6	
6.1	3	Int.	□	0610S-DIN	79	34	36	8
	3	Int.	□	0610S-DIN-C	79	34	36	8
	5	Int.	□	0610L-DIN	91	53	36	8
	5	Int.	□	0610L-DIN-C	91	53	36	8
	8	Int.	□	0610-L8C	113	73	36	8
	10	Int.	□	0610-L10C	126	86	36	8
	12	Int.	□	0610-L12C	139	99	36	8
	15	Int.	□	0610-L15C	158	118	36	8
	20	Int.	□	0610-L20C	191	151	36	8
	25	Int.	□	0610-L25C	223	183	36	8
30	Int.	□	0610-L30C	256	216	36	8	



DRILLING (SOLID CARBIDE)

MNS



P	M	K	S	N	H
---	---	---	---	---	----------

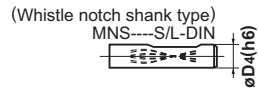
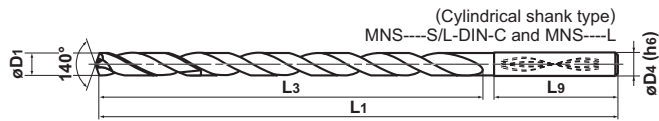

■ MNS○○○○S/L-DIN, MNS○○○○S/L-DIN-C Type

D1	3.0<D1≤6.0	6.0<D1≤10.0	10.0<D1≤18.0	18.0<D1≤20.0
Tolerance	+0.016 +0.004	+0.021 +0.006	+0.025 +0.007	+0.029 +0.008

■ MNS○○○○-L○C, MNS○○○○-L○C Type

D1	D1≤3.0	3.0<D1≤6.0	6.0<D1≤10.0	10.0<D1≤18.0	18.0<D1≤20.0
Tolerance	0 -0.014	0 -0.018	0 -0.022	0 -0.027	0 -0.033

(Note) MNS type can be used for shrink fit holders.

Drill Dia. D1 (mm)	Hole Depth (l/d)	Coolant (Int./Ext.)	Stock TF15	Order Number	Dimensions (mm)			
					L1	L3	L9	D4
6.2	3	Int.	□	MNS0620S-DIN	79	34	36	8
	3	Int.	□	0620S-DIN-C	79	34	36	8
	5	Int.	□	0620L-DIN	91	53	36	8
	5	Int.	□	0620L-DIN-C	91	53	36	8
	8	Int.	□	0620-L8C	113	73	36	8
	10	Int.	□	0620-L10C	126	86	36	8
	12	Int.	□	0620-L12C	139	99	36	8
	15	Int.	□	0620-L15C	158	118	36	8
	20	Int.	□	0620-L20C	191	151	36	8
	25	Int.	□	0620-L25C	223	183	36	8
30	Int.	□	0620-L30C	256	216	36	8	
6.3	3	Int.	□	0630S-DIN	79	34	36	8
	3	Int.	□	0630S-DIN-C	79	34	36	8
	5	Int.	□	0630L-DIN	91	53	36	8
	5	Int.	□	0630L-DIN-C	91	53	36	8
	8	Int.	□	0630-L8C	113	73	36	8
	10	Int.	□	0630-L10C	126	86	36	8
	12	Int.	□	0630-L12C	139	99	36	8
	15	Int.	□	0630-L15C	158	118	36	8
	20	Int.	□	0630-L20C	191	151	36	8
	25	Int.	□	0630-L25C	223	183	36	8
30	Int.	□	0630-L30C	256	216	36	8	
6.4	3	Int.	□	0640S-DIN	79	34	36	8
	3	Int.	□	0640S-DIN-C	79	34	36	8
	5	Int.	□	0640L-DIN	91	53	36	8
	5	Int.	□	0640L-DIN-C	91	53	36	8
	8	Int.	□	0640-L8C	113	73	36	8
	10	Int.	□	0640-L10C	126	86	36	8
	12	Int.	□	0640-L12C	139	99	36	8
	15	Int.	□	0640-L15C	158	118	36	8
	20	Int.	□	0640-L20C	191	151	36	8
	25	Int.	□	0640-L25C	223	183	36	8
30	Int.	□	0640-L30C	256	216	36	8	

Drill Dia. D1 (mm)	Hole Depth (l/d)	Coolant (Int./Ext.)	Stock TF15	Order Number	Dimensions (mm)			
					L1	L3	L9	D4
6.5	3	Int.	□	MNS0650S-DIN	79	34	36	8
	3	Int.	□	0650S-DIN-C	79	34	36	8
	5	Int.	□	0650L-DIN	91	53	36	8
	5	Int.	●	0650L-DIN-C	91	53	36	8
	8	Int.	□	0650-L8C	113	73	36	8
	10	Int.	□	0650-L10C	126	86	36	8
	12	Int.	●	0650-L12C	139	99	36	8
	15	Int.	□	0650-L15C	158	118	36	8
	20	Int.	●	0650-L20C	191	151	36	8
	25	Int.	□	0650-L25C	223	183	36	8
30	Int.	●	0650-L30C	256	216	36	8	
6.6	3	Int.	□	0660S-DIN	79	34	36	8
	3	Int.	□	0660S-DIN-C	79	34	36	8
	5	Int.	□	0660L-DIN	91	53	36	8
	5	Int.	□	0660L-DIN-C	91	53	36	8
	8	Int.	□	0660-L8C	118	78	36	8
	10	Int.	□	0660-L10C	132	92	36	8
	12	Int.	□	0660-L12C	146	106	36	8
	15	Int.	□	0660-L15C	167	127	36	8
	20	Int.	□	0660-L20C	202	162	36	8
	25	Int.	□	0660-L25C	237	197	36	8
30	Int.	□	0660-L30C	272	232	36	8	
6.7	3	Int.	□	0670S-DIN	79	34	36	8
	3	Int.	□	0670S-DIN-C	79	34	36	8
	5	Int.	□	0670L-DIN	91	53	36	8
	5	Int.	□	0670L-DIN-C	91	53	36	8
	8	Int.	□	0670-L8C	118	78	36	8
	10	Int.	□	0670-L10C	132	92	36	8
	12	Int.	□	0670-L12C	146	106	36	8
	15	Int.	□	0670-L15C	167	127	36	8
	20	Int.	□	0670-L20C	202	162	36	8
	25	Int.	□	0670-L25C	237	197	36	8
30	Int.	□	0670-L30C	272	232	36	8	

(Note) Please contact Mitsubishi Carbide for any geometry that is not in the brochure (e.g. different diameter and length).

DRILLING MNS DRILLS

Ø 6.2 ~ 6.7

- : Stock Standard
- ★ : Stock Standard in Japan.
- : Non stock, produced to order only

Drill Dia. D1 (mm)	Hole Depth (l/d)	Coolant (Int./Ext.)	Stock TF15	Order Number	Dimensions (mm)			
					L1	L3	L9	D4
6.8	3	Int.	□	MNS0680S-DIN	79	34	36	8
	3	Int.	□	0680S-DIN-C	79	34	36	8
	5	Int.	□	0680L-DIN	79	34	36	8
	5	Int.	●	0680L-DIN-C	91	53	36	8
	8	Int.	□	0680-L8C	118	78	36	8
	10	Int.	□	0680-L10C	132	92	36	8
	12	Int.	●	0680-L12C	146	106	36	8
	15	Int.	□	0680-L15C	167	127	36	8
	20	Int.	●	0680-L20C	202	162	36	8
	25	Int.	□	0680-L25C	237	197	36	8
30	Int.	●	0680-L30C	272	232	36	8	
6.9	3	Int.	□	0690S-DIN	79	34	36	8
	3	Int.	□	0690S-DIN-C	79	34	36	8
	5	Int.	□	0690L-DIN	91	53	36	8
	5	Int.	□	0690L-DIN-C	91	53	36	8
	8	Int.	□	0690-L8C	118	78	36	8
	10	Int.	□	0690-L10C	132	92	36	8
	12	Int.	□	0690-L12C	146	106	36	8
	15	Int.	□	0690-L15C	167	127	36	8
	20	Int.	□	0690-L20C	202	162	36	8
	25	Int.	□	0690-L25C	237	197	36	8
30	Int.	□	0690-L30C	272	232	36	8	
7.0	3	Int.	□	0700S-DIN	79	34	36	8
	3	Int.	□	0700S-DIN-C	79	34	36	8
	5	Int.	□	0700L-DIN	91	53	36	8
	5	Int.	●	0700L-DIN-C	91	53	36	8
	8	Int.	□	0700-L8C	118	78	36	8
	10	Int.	□	0700-L10C	132	92	36	8
	12	Int.	●	0700-L12C	146	106	36	8
	15	Int.	□	0700-L15C	167	127	36	8
	20	Int.	●	0700-L20C	202	162	36	8
	25	Int.	□	0700-L25C	237	197	36	8
30	Int.	●	0700-L30C	272	232	36	8	
7.1	3	Int.	□	0710S-DIN	79	41	36	8
	3	Int.	□	0710S-DIN-C	79	41	36	8
	5	Int.	□	0710L-DIN	91	53	36	8
	5	Int.	□	0710L-DIN-C	91	53	36	8
	8	Int.	□	0710-L8C	124	84	36	8
	10	Int.	□	0710-L10C	139	99	36	8
	12	Int.	□	0710-L12C	154	114	36	8
	15	Int.	□	0710-L15C	176	136	36	8
	20	Int.	□	0710-L20C	214	174	36	8
	25	Int.	□	0710-L25C	251	211	36	8
30	Int.	□	0710-L30C	289	249	36	8	
7.2	3	Int.	□	0720S-DIN	79	41	36	8
	3	Int.	□	0720S-DIN-C	79	41	36	8
	5	Int.	□	0720L-DIN	91	53	36	8
	5	Int.	□	0720L-DIN-C	91	53	36	8
	8	Int.	□	0720-L8C	124	84	36	8
	10	Int.	□	0720-L10C	139	99	36	8
	12	Int.	□	0720-L12C	154	114	36	8
	15	Int.	□	0720-L15C	176	136	36	8
	20	Int.	□	0720-L20C	214	174	36	8
	25	Int.	□	0720-L25C	251	211	36	8
30	Int.	□	0720-L30C	289	249	36	8	

Drill Dia. D1 (mm)	Hole Depth (l/d)	Coolant (Int./Ext.)	Stock TF15	Order Number	Dimensions (mm)			
					L1	L3	L9	D4
7.3	3	Int.	□	MNS0730S-DIN	79	41	36	8
	3	Int.	□	0730S-DIN-C	79	41	36	8
	5	Int.	□	0730L-DIN	91	53	36	8
	5	Int.	□	0730L-DIN-C	91	53	36	8
	8	Int.	□	0730-L8C	124	84	36	8
	10	Int.	□	0730-L10C	139	99	36	8
	12	Int.	□	0730-L12C	154	114	36	8
	15	Int.	□	0730-L15C	176	136	36	8
	20	Int.	□	0730-L20C	214	174	36	8
	25	Int.	□	0730-L25C	251	211	36	8
30	Int.	□	0730-L30C	289	249	36	8	
7.4	3	Int.	□	0740S-DIN	79	41	36	8
	3	Int.	□	0740S-DIN-C	79	41	36	8
	5	Int.	□	0740L-DIN	91	53	36	8
	5	Int.	□	0740L-DIN-C	91	53	36	8
	8	Int.	□	0740-L8C	124	84	36	8
	10	Int.	□	0740-L10C	139	99	36	8
	12	Int.	□	0740-L12C	154	114	36	8
	15	Int.	□	0740-L15C	176	136	36	8
	20	Int.	□	0740-L20C	214	174	36	8
	25	Int.	□	0740-L25C	251	211	36	8
30	Int.	□	0740-L30C	289	249	36	8	
7.5	3	Int.	□	0750S-DIN	79	41	36	8
	3	Int.	□	0750S-DIN-C	79	41	36	8
	5	Int.	□	0750L-DIN	91	53	36	8
	5	Int.	□	0750L-DIN-C	91	53	36	8
	8	Int.	□	0750-L8C	124	84	36	8
	10	Int.	□	0750-L10C	139	99	36	8
	12	Int.	□	0750-L12C	154	114	36	8
	15	Int.	□	0750-L15C	176	136	36	8
	20	Int.	□	0750-L20C	214	174	36	8
	25	Int.	□	0750-L25C	251	211	36	8
30	Int.	□	0750-L30C	289	249	36	8	
7.6	3	Int.	□	0760S-DIN	79	41	36	8
	3	Int.	□	0760S-DIN-C	79	41	36	8
	5	Int.	□	0760L-DIN	91	53	36	8
	5	Int.	□	0760L-DIN-C	91	53	36	8
	8	Int.	□	0760-L8C	129	89	36	8
	10	Int.	□	0760-L10C	145	105	36	8
	12	Int.	□	0760-L12C	161	121	36	8
	15	Int.	□	0760-L15C	185	145	36	8
	20	Int.	□	0760-L20C	225	185	36	8
	25	Int.	□	0760-L25C	265	225	36	8
30	Int.	□	0760-L30C	305	265	36	8	
7.7	3	Int.	□	0770S-DIN	79	41	36	8
	3	Int.	□	0770S-DIN-C	79	41	36	8
	5	Int.	□	0770L-DIN	91	53	36	8
	5	Int.	□	0770L-DIN-C	91	53	36	8
	8	Int.	□	0770-L8C	129	89	36	8
	10	Int.	□	0770-L10C	145	105	36	8
	12	Int.	□	0770-L12C	161	121	36	8
	15	Int.	□	0770-L15C	185	145	36	8
	20	Int.	□	0770-L20C	225	185	36	8
	25	Int.	□	0770-L25C	265	225	36	8
30	Int.	□	0770-L30C	305	265	36	8	

MNS DRILLS



Ø 6.8 ~ 7.7

CUTTING CONDITIONS

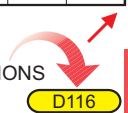

D116

D099

DRILLING (SOLID CARBIDE)

MNS



P	M	K	S	N	H
---	---	---	---	---	----------

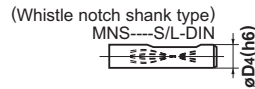
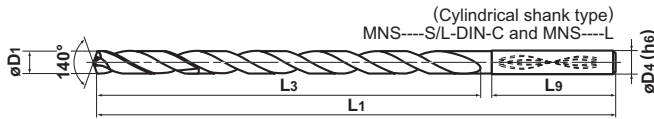

MNS○○○○S/L-DIN, MNS○○○○S/L-DIN-C Type

D1	3.0<D1≤6.0	6.0<D1≤10.0	10.0<D1≤18.0	18.0<D1≤20.0
Tolerance	+0.016 +0.004	+0.021 +0.006	+0.025 +0.007	+0.029 +0.008

MNS○○○○-L○C, MNS○○○○-L○C Type

D1	D1≤3.0	3.0<D1≤6.0	6.0<D1≤10.0	10.0<D1≤18.0	18.0<D1≤20.0
Tolerance	0 -0.014	0 -0.018	0 -0.022	0 -0.027	0 -0.033

(Note) MNS type can be used for shrink fit holders.

Drill Dia. D1 (mm)	Hole Depth (l/d)	Coolant (Int./Ext.)	Stock TF15	Order Number	Dimensions (mm)			
					L1	L3	L9	D4
7.8	3	Int.	□	MNS0780S-DIN	79	41	36	8
	3	Int.	□	0780S-DIN-C	79	41	36	8
	5	Int.	□	0780L-DIN	91	53	36	8
	5	Int.	□	0780L-DIN-C	91	53	36	8
	8	Int.	□	0780-L8C	129	89	36	8
	10	Int.	□	0780-L10C	145	105	36	8
	12	Int.	□	0780-L12C	161	121	36	8
	15	Int.	□	0780-L15C	185	145	36	8
	20	Int.	□	0780-L20C	225	185	36	8
7.9	3	Int.	□	0790S-DIN	79	41	36	8
	3	Int.	□	0790S-DIN-C	79	41	36	8
	5	Int.	□	0790L-DIN	91	53	36	8
	5	Int.	□	0790L-DIN-C	91	53	36	8
	8	Int.	□	0790-L8C	129	89	36	8
	10	Int.	□	0790-L10C	145	105	36	8
	12	Int.	□	0790-L12C	161	121	36	8
	15	Int.	□	0790-L15C	185	145	36	8
	20	Int.	□	0790-L20C	225	185	36	8
8.0	3	Int.	□	0800S-DIN	79	41	36	8
	3	Int.	□	0800S-DIN-C	79	41	36	8
	5	Int.	□	0800L-DIN	91	53	36	8
	5	Int.	●	0800L-DIN-C	91	53	36	8
	8	Int.	□	0800-L8C	129	89	36	8
	10	Int.	□	0800-L10C	145	105	36	8
	12	Int.	●	0800-L12C	161	121	36	8
	15	Int.	□	0800-L15C	185	145	36	8
	20	Int.	●	0800-L20C	225	185	36	8

Drill Dia. D1 (mm)	Hole Depth (l/d)	Coolant (Int./Ext.)	Stock TF15	Order Number	Dimensions (mm)			
					L1	L3	L9	D4
8.1	3	Int.	□	MNS0810S-DIN	88	46	40	10
	3	Int.	□	0810S-DIN-C	88	46	40	10
	5	Int.	□	0810L-DIN	102	60	40	10
	5	Int.	□	0810L-DIN-C	102	60	40	10
	8	Int.	□	0810-L8C	139	95	40	10
	10	Int.	□	0810-L10C	156	112	40	10
	12	Int.	□	0810-L12C	173	129	40	10
	15	Int.	□	0810-L15C	198	154	40	10
	20	Int.	□	0810-L20C	241	197	40	10
8.2	3	Int.	□	0820S-DIN	88	46	40	10
	3	Int.	□	0820S-DIN-C	88	46	40	10
	5	Int.	□	0820L-DIN	102	60	40	10
	5	Int.	□	0820L-DIN-C	102	60	40	10
	8	Int.	□	0820-L8C	139	95	40	10
	10	Int.	□	0820-L10C	156	112	40	10
	12	Int.	□	0820-L12C	173	129	40	10
	15	Int.	□	0820-L15C	198	154	40	10
	20	Int.	□	0820-L20C	241	197	40	10
8.3	3	Int.	□	0830S-DIN	88	46	40	10
	3	Int.	□	0830S-DIN-C	88	46	40	10
	5	Int.	□	0830L-DIN	102	60	40	10
	5	Int.	□	0830L-DIN-C	102	60	40	10
	8	Int.	□	0830-L8C	139	95	40	10
	10	Int.	□	0830-L10C	156	112	40	10
	12	Int.	□	0830-L12C	173	129	40	10
	15	Int.	□	0830-L15C	198	154	40	10
	20	Int.	□	0830-L20C	241	197	40	10

(Note) Please contact Mitsubishi Carbide for any geometry that is not in the brochure (e.g. different diameter and length).

DRILLING | MNS DRILLS

Ø 7.8 ~ 8.3

- : Stock Standard
- ★ : Stock Standard in Japan.
- : Non stock, produced to order only

Drill Dia. D1 (mm)	Hole Depth (l/d)	Coolant (Int./Ext.)	Stock TF15	Order Number	Dimensions (mm)			
					L1	L3	L9	D4
8.4	3	Int.	□	MNS0840S-DIN	88	46	40	10
	3	Int.	□	0840S-DIN-C	88	46	40	10
	5	Int.	□	0840L-DIN	102	60	40	10
	5	Int.	□	0840L-DIN-C	102	60	40	10
	8	Int.	□	0840-L8C	139	95	40	10
	10	Int.	□	0840-L10C	156	112	40	10
	12	Int.	□	0840-L12C	173	129	40	10
	15	Int.	□	0840-L15C	198	154	40	10
	20	Int.	□	0840-L20C	241	197	40	10
	25	Int.	□	0840-L25C	283	239	40	10
30	Int.	□	0840-L30C	326	282	40	10	
8.5	3	Int.	□	0850S-DIN	88	46	40	10
	3	Int.	□	0850S-DIN-C	88	46	40	10
	5	Int.	□	0850L-DIN	102	60	40	10
	5	Int.	●	0850L-DIN-C	102	60	40	10
	8	Int.	□	0850-L8C	139	95	40	10
	10	Int.	□	0850-L10C	156	112	40	10
	12	Int.	●	0850-L12C	173	129	40	10
	15	Int.	□	0850-L15C	198	154	40	10
	20	Int.	●	0850-L20C	241	197	40	10
	25	Int.	□	0850-L25C	283	239	40	10
30	Int.	●	0850-L30C	326	282	40	10	
8.6	3	Int.	□	0860S-DIN	88	46	40	10
	3	Int.	□	0860S-DIN-C	88	46	40	10
	5	Int.	□	0860L-DIN	102	60	40	10
	5	Int.	□	0860L-DIN-C	102	60	40	10
	8	Int.	□	0860-L8C	144	100	40	10
	10	Int.	□	0860-L10C	162	118	40	10
	12	Int.	□	0860-L12C	180	136	40	10
	15	Int.	□	0860-L15C	207	163	40	10
	20	Int.	□	0860-L20C	252	208	40	10
	25	Int.	□	0860-L25C	297	253	40	10
30	Int.	□	0860-L30C	342	298	40	10	
8.7	3	Int.	□	0870S-DIN	88	46	40	10
	3	Int.	□	0870S-DIN-C	88	46	40	10
	5	Int.	□	0870L-DIN	102	60	40	10
	5	Int.	□	0870L-DIN-C	102	60	40	10
	8	Int.	□	0870-L8C	144	100	40	10
	10	Int.	□	0870-L10C	162	118	40	10
	12	Int.	□	0870-L12C	180	136	40	10
	15	Int.	□	0870-L15C	207	163	40	10
	20	Int.	□	0870-L20C	252	208	40	10
	25	Int.	□	0870-L25C	297	253	40	10
30	Int.	□	0870-L30C	342	298	40	10	
8.8	3	Int.	□	0880S-DIN	88	46	40	10
	3	Int.	□	0880S-DIN-C	88	46	40	10
	5	Int.	□	0880L-DIN	102	60	40	10
	5	Int.	□	0880L-DIN-C	102	60	40	10
	8	Int.	□	0880-L8C	144	100	40	10
	10	Int.	□	0880-L10C	162	118	40	10
	12	Int.	□	0880-L12C	180	136	40	10
	15	Int.	□	0880-L15C	207	163	40	10
	20	Int.	□	0880-L20C	252	208	40	10
	25	Int.	□	0880-L25C	297	253	40	10
30	Int.	□	0880-L30C	342	298	40	10	

Drill Dia. D1 (mm)	Hole Depth (l/d)	Coolant (Int./Ext.)	Stock TF15	Order Number	Dimensions (mm)			
					L1	L3	L9	D4
8.9	3	Int.	□	MNS0890S-DIN	88	46	40	10
	3	Int.	□	0890S-DIN-C	88	46	40	10
	5	Int.	□	0890L-DIN	102	60	40	10
	5	Int.	□	0890L-DIN-C	102	60	40	10
	8	Int.	□	0890-L8C	144	100	40	10
	10	Int.	□	0890-L10C	162	118	40	10
	12	Int.	□	0890-L12C	180	136	40	10
	15	Int.	□	0890-L15C	207	163	40	10
	20	Int.	□	0890-L20C	252	208	40	10
	25	Int.	□	0890-L25C	297	253	40	10
30	Int.	□	0890-L30C	342	298	40	10	
9.0	3	Int.	□	0900S-DIN	88	46	40	10
	3	Int.	□	0900S-DIN-C	88	46	40	10
	5	Int.	□	0900L-DIN	102	60	40	10
	5	Int.	●	0900L-DIN-C	102	60	40	10
	8	Int.	□	0900-L8C	144	100	40	10
	10	Int.	□	0900-L10C	162	118	40	10
	12	Int.	●	0900-L12C	180	136	40	10
	15	Int.	□	0900-L15C	207	163	40	10
	20	Int.	●	0900-L20C	252	208	40	10
	25	Int.	□	0900-L25C	297	253	40	10
30	Int.	●	0900-L30C	342	298	40	10	
9.1	3	Int.	□	0910S-DIN	89	47	40	10
	3	Int.	□	0910S-DIN-C	89	47	40	10
	5	Int.	□	0910L-DIN	103	62	40	10
	5	Int.	□	0910L-DIN-C	103	62	40	10
	8	Int.	□	0910-L8C	151	107	40	10
	10	Int.	□	0910-L10C	170	126	40	10
	12	Int.	□	0910-L12C	189	145	40	10
	15	Int.	□	0910-L15C	217	173	40	10
	20	Int.	□	0910-L20C	265	221	40	10
	25	Int.	□	0910-L25C	312	268	40	10
30	Int.	□	0910-L30C	360	316	40	10	
9.2	3	Int.	□	0920S-DIN	89	47	40	10
	3	Int.	□	0920S-DIN-C	89	47	40	10
	5	Int.	□	0920L-DIN	103	62	40	10
	5	Int.	□	0920L-DIN-C	103	62	40	10
	8	Int.	□	0920-L8C	151	107	40	10
	10	Int.	□	0920-L10C	170	126	40	10
	12	Int.	□	0920-L12C	189	145	40	10
	15	Int.	□	0920-L15C	217	173	40	10
	20	Int.	□	0920-L20C	265	221	40	10
	25	Int.	□	0920-L25C	312	268	40	10
30	Int.	□	0920-L30C	360	316	40	10	
9.3	3	Int.	□	0930S-DIN	89	47	40	10
	3	Int.	□	0930S-DIN-C	89	47	40	10
	5	Int.	□	0930L-DIN	103	62	40	10
	5	Int.	□	0930L-DIN-C	103	62	40	10
	8	Int.	□	0930-L8C	151	107	40	10
	10	Int.	□	0930-L10C	170	126	40	10
	12	Int.	□	0930-L12C	189	145	40	10
	15	Int.	□	0930-L15C	217	173	40	10
	20	Int.	□	0930-L20C	265	221	40	10
	25	Int.	□	0930-L25C	312	268	40	10
30	Int.	□	0930-L30C	360	316	40	10	

MNS DRILLS



Ø 8.4 ~ 9.3

CUTTING CONDITIONS

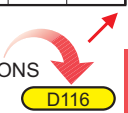

D116

D101

DRILLING (SOLID CARBIDE)

MNS



P	M	K	S	N	H
---	---	---	---	---	----------

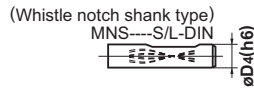
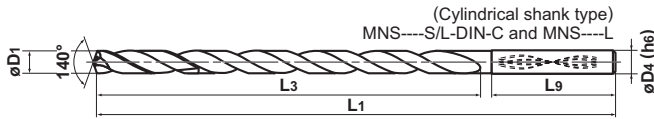

■ MNS○○○○S/L-DIN, MNS○○○○S/L-DIN-C Type

D1	3.0<D1≤6.0	6.0<D1≤10.0	10.0<D1≤18.0	18.0<D1≤20.0
Tolerance	+0.016 +0.004	+0.021 +0.006	+0.025 +0.007	+0.029 +0.008

■ MNS○○○○-L○C, MNS○○○○-L○C Type

D1	D1≤3.0	3.0<D1≤6.0	6.0<D1≤10.0	10.0<D1≤18.0	18.0<D1≤20.0
Tolerance	0 -0.014	0 -0.018	0 -0.022	0 -0.027	0 -0.033

(Note) MNS type can be used for shrink fit holders.

Drill Dia. D1 (mm)	Hole Depth (l/d)	Coolant (Int./Ext.)	Stock TF15	Order Number	Dimensions (mm)			
					L1	L3	L9	D4
9.4	3	Int.	<input type="checkbox"/>	MNS0940S-DIN	89	47	40	10
	3	Int.	<input type="checkbox"/>	0940S-DIN-C	89	47	40	10
	5	Int.	<input type="checkbox"/>	0940L-DIN	103	62	40	10
	5	Int.	<input type="checkbox"/>	0940L-DIN-C	103	62	40	10
	8	Int.	<input type="checkbox"/>	0940-L8C	151	107	40	10
	10	Int.	<input type="checkbox"/>	0940-L10C	170	126	40	10
	12	Int.	<input type="checkbox"/>	0940-L12C	189	145	40	10
	15	Int.	<input type="checkbox"/>	0940-L15C	217	173	40	10
	20	Int.	<input type="checkbox"/>	0940-L20C	265	221	40	10
	25	Int.	<input type="checkbox"/>	0940-L25C	312	268	40	10
30	Int.	<input type="checkbox"/>	0940-L30C	360	316	40	10	
9.5	3	Int.	<input type="checkbox"/>	0950S-DIN	89	47	40	10
	3	Int.	<input type="checkbox"/>	0950S-DIN-C	89	47	40	10
	5	Int.	<input type="checkbox"/>	0950L-DIN	103	62	40	10
	5	Int.	<input type="checkbox"/>	0950L-DIN-C	103	62	40	10
	8	Int.	<input type="checkbox"/>	0950-L8C	151	107	40	10
	10	Int.	<input type="checkbox"/>	0950-L10C	170	126	40	10
	12	Int.	<input type="checkbox"/>	0950-L12C	189	145	40	10
	15	Int.	<input type="checkbox"/>	0950-L15C	217	173	40	10
	20	Int.	<input type="checkbox"/>	0950-L20C	265	221	40	10
	25	Int.	<input type="checkbox"/>	0950-L25C	312	268	40	10
30	Int.	<input type="checkbox"/>	0950-L30C	360	316	40	10	
9.6	3	Int.	<input type="checkbox"/>	0960S-DIN	89	47	40	10
	3	Int.	<input type="checkbox"/>	0960S-DIN-C	89	47	40	10
	5	Int.	<input type="checkbox"/>	0960L-DIN	103	62	40	10
	5	Int.	<input type="checkbox"/>	0960L-DIN-C	103	62	40	10
	8	Int.	<input type="checkbox"/>	0960-L8C	156	112	40	10
	10	Int.	<input type="checkbox"/>	0960-L10C	176	132	40	10
	12	Int.	<input type="checkbox"/>	0960-L12C	196	152	40	10
	15	Int.	<input type="checkbox"/>	0960-L15C	226	182	40	10
	20	Int.	<input type="checkbox"/>	0960-L20C	276	232	40	10
	25	Int.	<input type="checkbox"/>	0960-L25C	326	282	40	10
30	Int.	<input type="checkbox"/>	0960-L30C	376	332	40	10	

Drill Dia. D1 (mm)	Hole Depth (l/d)	Coolant (Int./Ext.)	Stock TF15	Order Number	Dimensions (mm)			
					L1	L3	L9	D4
9.7	3	Int.	<input type="checkbox"/>	MNS0970S-DIN	89	47	40	10
	3	Int.	<input type="checkbox"/>	0970S-DIN-C	89	47	40	10
	5	Int.	<input type="checkbox"/>	0970L-DIN	103	62	40	10
	5	Int.	<input type="checkbox"/>	0970L-DIN-C	103	62	40	10
	8	Int.	<input type="checkbox"/>	0970-L8C	156	112	40	10
	10	Int.	<input type="checkbox"/>	0970-L10C	176	132	40	10
	12	Int.	<input type="checkbox"/>	0970-L12C	196	152	40	10
	15	Int.	<input type="checkbox"/>	0970-L15C	226	182	40	10
	20	Int.	<input type="checkbox"/>	0970-L20C	276	232	40	10
	25	Int.	<input type="checkbox"/>	0970-L25C	326	282	40	10
30	Int.	<input type="checkbox"/>	0970-L30C	376	332	40	10	
9.8	3	Int.	<input type="checkbox"/>	0980S-DIN	89	47	40	10
	3	Int.	<input type="checkbox"/>	0980S-DIN-C	89	47	40	10
	5	Int.	<input type="checkbox"/>	0980L-DIN	103	62	40	10
	5	Int.	<input type="checkbox"/>	0980L-DIN-C	103	62	40	10
	8	Int.	<input type="checkbox"/>	0980-L8C	156	112	40	10
	10	Int.	<input type="checkbox"/>	0980-L10C	176	132	40	10
	12	Int.	<input type="checkbox"/>	0980-L12C	196	152	40	10
	15	Int.	<input type="checkbox"/>	0980-L15C	226	182	40	10
	20	Int.	<input type="checkbox"/>	0980-L20C	276	232	40	10
	25	Int.	<input type="checkbox"/>	0980-L25C	326	282	40	10
30	Int.	<input type="checkbox"/>	0980-L30C	376	332	40	10	
9.9	3	Int.	<input type="checkbox"/>	0990S-DIN	89	47	40	10
	3	Int.	<input type="checkbox"/>	0990S-DIN-C	89	47	40	10
	5	Int.	<input type="checkbox"/>	0990L-DIN	103	62	40	10
	5	Int.	<input type="checkbox"/>	0990L-DIN-C	103	62	40	10
	8	Int.	<input type="checkbox"/>	0990-L8C	156	112	40	10
	10	Int.	<input type="checkbox"/>	0990-L10C	176	132	40	10
	12	Int.	<input type="checkbox"/>	0990-L12C	196	152	40	10
	15	Int.	<input type="checkbox"/>	0990-L15C	226	182	40	10
	20	Int.	<input type="checkbox"/>	0990-L20C	276	232	40	10
	25	Int.	<input type="checkbox"/>	0990-L25C	326	282	40	10
30	Int.	<input type="checkbox"/>	0990-L30C	376	332	40	10	

(Note) Please contact Mitsubishi Carbide for any geometry that is not in the brochure (e.g. different diameter and length).

DRILLING | MNS DRILLS

Ø 9.4 ~ 9.9

- : Stock Standard
- ★ : Stock Standard in Japan.
- : Non stock, produced to order only

Drill Dia. D1 (mm)	Hole Depth (l/d)	Coolant (Int./Ext.)	Stock TF15	Order Number	Dimensions (mm)			
					L1	L3	L9	D4
10.0	3	Int.	□	MNS1000S-DIN	89	47	40	10
	3	Int.	□	1000S-DIN-C	89	47	40	10
	5	Int.	□	1000L-DIN	103	62	40	10
	5	Int.	●	1000L-DIN-C	103	62	40	10
	8	Int.	□	1000-L8C	156	112	40	10
	10	Int.	□	1000-L10C	176	132	40	10
	12	Int.	●	1000-L12C	196	152	40	10
	15	Int.	□	1000-L15C	226	182	40	10
	20	Int.	●	1000-L20C	276	232	40	10
	25	Int.	□	1000-L25C	326	282	40	10
30	Int.	●	1000-L30C	376	332	40	10	
10.1	3	Int.	□	1010S-DIN	102	55	45	12
	3	Int.	□	1010S-DIN-C	102	55	45	12
	5	Int.	□	1010L-DIN	118	71	45	12
	5	Int.	□	1010L-DIN-C	118	71	45	12
	8	Int.	□	1010-L8C	167	118	45	12
	10	Int.	□	1010-L10C	188	139	45	12
	12	Int.	□	1010-L12C	209	160	45	12
	15	Int.	□	1010-L15C	240	191	45	12
	20	Int.	□	1010-L20C	293	244	45	12
	25	Int.	□	1010-L25C	345	296	45	12
10.2	3	Int.	□	1020S-DIN	102	55	45	12
	3	Int.	□	1020S-DIN-C	102	55	45	12
	5	Int.	□	1020L-DIN	118	71	45	12
	5	Int.	□	1020L-DIN-C	118	71	45	12
	8	Int.	□	1020-L8C	167	118	45	12
	10	Int.	□	1020-L10C	188	139	45	12
	12	Int.	□	1020-L12C	209	160	45	12
	15	Int.	□	1020-L15C	240	191	45	12
	20	Int.	□	1020-L20C	293	244	45	12
	25	Int.	□	1020-L25C	345	296	45	12
10.3	3	Int.	□	1030S-DIN	102	55	45	12
	3	Int.	□	1030S-DIN-C	102	55	45	12
	5	Int.	□	1030L-DIN	118	71	45	12
	5	Int.	□	1030L-DIN-C	118	71	45	12
	8	Int.	□	1030-L8C	167	118	45	12
	10	Int.	□	1030-L10C	188	139	45	12
	12	Int.	□	1030-L12C	209	160	45	12
	15	Int.	□	1030-L15C	240	191	45	12
	20	Int.	□	1030-L20C	293	244	45	12
	25	Int.	□	1030-L25C	345	296	45	12
10.4	3	Int.	□	1040S-DIN	102	55	45	12
	3	Int.	□	1040S-DIN-C	102	55	45	12
	5	Int.	□	1040L-DIN	118	71	45	12
	5	Int.	□	1040L-DIN-C	118	71	45	12
	8	Int.	□	1040-L8C	167	118	45	12
	10	Int.	□	1040-L10C	188	139	45	12
	12	Int.	□	1040-L12C	209	160	45	12
	15	Int.	□	1040-L15C	240	191	45	12
	20	Int.	□	1040-L20C	293	244	45	12
	25	Int.	□	1040-L25C	345	296	45	12

Drill Dia. D1 (mm)	Hole Depth (l/d)	Coolant (Int./Ext.)	Stock TF15	Order Number	Dimensions (mm)			
					L1	L3	L9	D4
10.5	3	Int.	□	MNS1050S-DIN	102	55	45	12
	3	Int.	□	1050S-DIN-C	102	55	45	12
	5	Int.	□	1050L-DIN	118	71	45	12
	5	Int.	□	1050L-DIN-C	118	71	45	12
	8	Int.	□	1050-L8C	167	118	45	12
	10	Int.	□	1050-L10C	188	139	45	12
	12	Int.	□	1050-L12C	209	160	45	12
	15	Int.	□	1050-L15C	240	191	45	12
	20	Int.	□	1050-L20C	293	244	45	12
	25	Int.	□	1050-L25C	345	296	45	12
10.6	3	Int.	□	1060S-DIN	102	55	45	12
	3	Int.	□	1060S-DIN-C	102	55	45	12
	5	Int.	□	1060L-DIN	118	71	45	12
	5	Int.	□	1060L-DIN-C	118	71	45	12
	8	Int.	□	1060-L8C	172	123	45	12
	10	Int.	□	1060-L10C	194	145	45	12
	12	Int.	□	1060-L12C	216	167	45	12
	15	Int.	□	1060-L15C	249	200	45	12
	20	Int.	□	1060-L20C	304	255	45	12
	25	Int.	□	1060-L25C	359	310	45	12
10.7	3	Int.	□	1070S-DIN	102	55	45	12
	3	Int.	□	1070S-DIN-C	102	55	45	12
	5	Int.	□	1070L-DIN	118	71	45	12
	5	Int.	□	1070L-DIN-C	118	71	45	12
	8	Int.	□	1070-L8C	172	123	45	12
	10	Int.	□	1070-L10C	194	145	45	12
	12	Int.	□	1070-L12C	216	167	45	12
	15	Int.	□	1070-L15C	249	200	45	12
	20	Int.	□	1070-L20C	304	255	45	12
	25	Int.	□	1070-L25C	359	310	45	12
10.8	3	Int.	□	1080S-DIN	102	55	45	12
	3	Int.	□	1080S-DIN-C	102	55	45	12
	5	Int.	□	1080L-DIN	118	71	45	12
	5	Int.	□	1080L-DIN-C	118	71	45	12
	8	Int.	□	1080-L8C	172	123	45	12
	10	Int.	□	1080-L10C	194	145	45	12
	12	Int.	□	1080-L12C	216	167	45	12
	15	Int.	□	1080-L15C	249	200	45	12
	20	Int.	□	1080-L20C	304	255	45	12
	25	Int.	□	1080-L25C	359	310	45	12
10.9	3	Int.	□	1090S-DIN	102	55	45	12
	3	Int.	□	1090S-DIN-C	102	55	45	12
	5	Int.	□	1090L-DIN	118	71	45	12
	5	Int.	□	1090L-DIN-C	118	71	45	12
	8	Int.	□	1090-L8C	172	123	45	12
	10	Int.	□	1090-L10C	194	145	45	12
	12	Int.	□	1090-L12C	216	167	45	12
	15	Int.	□	1090-L15C	249	200	45	12
	20	Int.	□	1090-L20C	304	255	45	12
	25	Int.	□	1090-L25C	359	310	45	12

MNS DRILLS



CUTTING CONDITIONS



D103

DRILLING (SOLID CARBIDE)

MNS



P	M	K	S	N	H
---	---	---	---	---	---

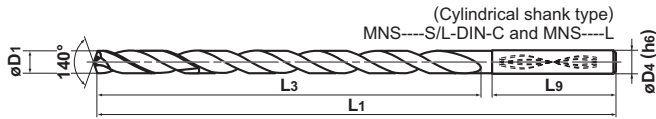

(Cylindrical shank type)
MNS---S/L-DIN-C and MNS---L

(Whistle notch shank type)
MNS---S/L-DIN

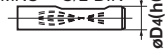

■ MNS○○○○S/L-DIN, MNS○○○○S/L-DIN-C Type

D1	3.0<D1≤6.0	6.0<D1≤10.0	10.0<D1≤18.0	18.0<D1≤20.0
Tolerance	+0.016 +0.004	+0.021 +0.006	+0.025 +0.007	+0.029 +0.008

■ MNS○○○○-L-OC, MNS○○○○-L-OCDC Type

D1	D1≤3.0	3.0<D1≤6.0	6.0<D1≤10.0	10.0<D1≤18.0	18.0<D1≤20.0
Tolerance	0 -0.014	0 -0.018	0 -0.022	0 -0.027	0 -0.033

(Note) MNS type can be used for shrink fit holders.

Drill Dia. D1 (mm)	Hole Depth (l/d)	Coolant (Int./Ext.)	Stock TF15	Order Number	Dimensions (mm)			
					L1	L3	L9	D4
11.0	3	Int.	□	MNS1100S-DIN	102	55	45	12
	3	Int.	□	1100S-DIN-C	102	55	45	12
	5	Int.	□	1100L-DIN	118	71	45	12
	5	Int.	●	1100L-DIN-C	118	71	45	12
	8	Int.	□	1100-L8C	172	123	45	12
	10	Int.	□	1100-L10C	194	145	45	12
	12	Int.	●	1100-L12C	216	167	45	12
	15	Int.	□	1100-L15C	249	200	45	12
	20	Int.	●	1100-L20C	304	255	45	12
25	Int.	□	1100-L25C	359	310	45	12	
11.1	3	Int.	□	1110S-DIN	102	55	45	12
	3	Int.	□	1110S-DIN-C	102	55	45	12
	5	Int.	□	1110L-DIN	118	71	45	12
	5	Int.	□	1110L-DIN-C	118	71	45	12
	8	Int.	□	1110-L8C	178	129	45	12
	10	Int.	□	1110-L10C	201	152	45	12
	12	Int.	□	1110-L12C	224	175	45	12
	15	Int.	□	1110-L15C	258	209	45	12
	20	Int.	□	1110-L20C	316	267	45	12
25	Int.	□	1110-L25C	373	324	45	12	
11.2	3	Int.	□	1120S-DIN	102	55	45	12
	3	Int.	□	1120S-DIN-C	102	55	45	12
	5	Int.	□	1120L-DIN	118	71	45	12
	5	Int.	□	1120L-DIN-C	118	71	45	12
	8	Int.	□	1120-L8C	178	129	45	12
	10	Int.	□	1120-L10C	201	152	45	12
	12	Int.	□	1120-L12C	224	175	45	12
	15	Int.	□	1120-L15C	258	209	45	12
	20	Int.	□	1120-L20C	316	267	45	12
25	Int.	□	1120-L25C	373	324	45	12	
11.3	3	Int.	□	1130S-DIN	102	55	45	12
	3	Int.	□	1130S-DIN-C	102	55	45	12
	5	Int.	□	1130L-DIN	118	71	45	12
	5	Int.	□	1130L-DIN-C	118	71	45	12
	8	Int.	□	1130-L8C	178	129	45	12
	10	Int.	□	1130-L10C	201	152	45	12
	12	Int.	□	1130-L12C	224	175	45	12
	15	Int.	□	1130-L15C	258	209	45	12
	20	Int.	□	1130-L20C	316	267	45	12
25	Int.	□	1130-L25C	373	324	45	12	

Drill Dia. D1 (mm)	Hole Depth (l/d)	Coolant (Int./Ext.)	Stock TF15	Order Number	Dimensions (mm)			
					L1	L3	L9	D4
11.4	3	Int.	□	MNS1140S-DIN	102	55	45	12
	3	Int.	□	1140S-DIN-C	102	55	45	12
	5	Int.	□	1140L-DIN	118	71	45	12
	5	Int.	□	1140L-DIN-C	118	71	45	12
	8	Int.	□	1140-L8C	178	129	45	12
	10	Int.	□	1140-L10C	201	152	45	12
	12	Int.	□	1140-L12C	224	175	45	12
	15	Int.	□	1140-L15C	258	209	45	12
	20	Int.	□	1140-L20C	316	267	45	12
25	Int.	□	1140-L25C	373	324	45	12	
11.5	3	Int.	□	1150S-DIN	102	55	45	12
	3	Int.	□	1150S-DIN-C	102	55	45	12
	5	Int.	□	1150L-DIN	118	71	45	12
	5	Int.	□	1150L-DIN-C	118	71	45	12
	8	Int.	□	1150-L8C	178	129	45	12
	10	Int.	□	1150-L10C	201	152	45	12
	12	Int.	□	1150-L12C	224	175	45	12
	15	Int.	□	1150-L15C	258	209	45	12
	20	Int.	□	1150-L20C	316	267	45	12
25	Int.	□	1150-L25C	373	324	45	12	
11.6	3	Int.	□	1160S-DIN	102	55	45	12
	3	Int.	□	1160S-DIN-C	102	55	45	12
	5	Int.	□	1160L-DIN	118	71	45	12
	5	Int.	□	1160L-DIN-C	118	71	45	12
	8	Int.	□	1160-L8C	183	134	45	12
	10	Int.	□	1160-L10C	207	158	45	12
	12	Int.	□	1160-L12C	231	182	45	12
	15	Int.	□	1160-L15C	267	218	45	12
	20	Int.	□	1160-L20C	327	278	45	12
25	Int.	□	1160-L25C	387	338	45	12	
11.7	3	Int.	□	1170S-DIN	102	55	45	12
	3	Int.	□	1170S-DIN-C	102	55	45	12
	5	Int.	□	1170L-DIN	118	71	45	12
	5	Int.	□	1170L-DIN-C	118	71	45	12
	8	Int.	□	1170-L8C	183	134	45	12
	10	Int.	□	1170-L10C	207	158	45	12
	12	Int.	□	1170-L12C	231	182	45	12
	15	Int.	□	1170-L15C	267	218	45	12
	20	Int.	□	1170-L20C	327	278	45	12
25	Int.	□	1170-L25C	387	338	45	12	

● : Stock Standard
★ : Stock Standard in Japan.
□ : Non stock, produced to order only

DRILLING | MNS DRILLS

Ø 11.0 ~ 11.7

Drill Dia. D1 (mm)	Hole Depth (l/d)	Coolant (Int./Ext.)	Stock TF15	Order Number	Dimensions (mm)			
					L1	L3	L9	D4
11.8	3	Int.	□	MNS1180S-DIN	102	55	45	12
	3	Int.	□	1180S-DIN-C	102	55	45	12
	5	Int.	□	1180L-DIN	118	71	45	12
	5	Int.	□	1180L-DIN-C	118	71	45	12
	8	Int.	□	1180-L8C	183	134	45	12
	10	Int.	□	1180-L10C	207	158	45	12
	12	Int.	□	1180-L12C	231	182	45	12
	15	Int.	□	1180-L15C	267	218	45	12
	20	Int.	□	1180-L20C	327	278	45	12
25	Int.	□	1180-L25C	387	338	45	12	
11.9	3	Int.	□	1190S-DIN	102	55	45	12
	3	Int.	□	1190S-DIN-C	102	55	45	12
	5	Int.	□	1190L-DIN	118	71	45	12
	5	Int.	□	1190L-DIN-C	118	71	45	12
	8	Int.	□	1190-L8C	183	134	45	12
	10	Int.	□	1190-L10C	207	158	45	12
	12	Int.	□	1190-L12C	231	182	45	12
	15	Int.	□	1190-L15C	267	218	45	12
	20	Int.	□	1190-L20C	327	278	45	12
25	Int.	□	1190-L25C	387	338	45	12	
12.0	3	Int.	□	1200S-DIN	102	55	45	12
	3	Int.	□	1200S-DIN-C	102	55	45	12
	5	Int.	□	1200L-DIN	118	71	45	12
	5	Int.	●	1200L-DIN-C	118	71	45	12
	8	Int.	□	1200-L8C	183	134	45	12
	10	Int.	□	1200-L10C	207	158	45	12
	12	Int.	●	1200-L12C	231	182	45	12
	15	Int.	□	1200-L15C	267	218	45	12
	20	Int.	●	1200-L20C	327	278	45	12
25	Int.	□	1200-L25C	387	338	45	12	
12.1	3	Int.	□	1210S-DIN	107	60	45	14
	3	Int.	□	1210S-DIN-C	107	60	45	14
	5	Int.	□	1210L-DIN	124	77	45	14
	5	Int.	□	1210L-DIN-C	124	77	45	14
	8	Int.	□	1210-L8C	189	140	45	14
	10	Int.	□	1210-L10C	214	165	45	14
	12	Int.	□	1210-L12C	239	190	45	14
	15	Int.	□	1210-L15C	276	227	45	14
	20	Int.	□	1210-L20C	339	290	45	14
12.2	3	Int.	□	1220S-DIN	107	60	45	14
	3	Int.	□	1220S-DIN-C	107	60	45	14
	5	Int.	□	1220L-DIN	124	77	45	14
	5	Int.	□	1220L-DIN-C	124	77	45	14
	8	Int.	□	1220-L8C	189	140	45	14
	10	Int.	□	1220-L10C	214	165	45	14
	12	Int.	□	1220-L12C	239	190	45	14
	15	Int.	□	1220-L15C	276	227	45	14
	20	Int.	□	1220-L20C	339	290	45	14

Drill Dia. D1 (mm)	Hole Depth (l/d)	Coolant (Int./Ext.)	Stock TF15	Order Number	Dimensions (mm)			
					L1	L3	L9	D4
12.3	3	Int.	□	MNS1230S-DIN	107	60	45	14
	3	Int.	□	1230S-DIN-C	107	60	45	14
	5	Int.	□	1230L-DIN	124	77	45	14
	5	Int.	□	1230L-DIN-C	124	77	45	14
	8	Int.	□	1230-L8C	189	140	45	14
	10	Int.	□	1230-L10C	214	165	45	14
	12	Int.	□	1230-L12C	239	190	45	14
	15	Int.	□	1230-L15C	276	227	45	14
	20	Int.	□	1230-L20C	339	290	45	14
12.4	3	Int.	□	1240S-DIN	107	60	45	14
	3	Int.	□	1240S-DIN-C	107	60	45	14
	5	Int.	□	1240L-DIN	124	77	45	14
	5	Int.	□	1240L-DIN-C	124	77	45	14
	8	Int.	□	1240-L8C	189	140	45	14
	10	Int.	□	1240-L10C	214	165	45	14
	12	Int.	□	1240-L12C	239	190	45	14
	15	Int.	□	1240-L15C	276	227	45	14
	20	Int.	□	1240-L20C	339	290	45	14
12.5	3	Int.	□	1250S-DIN	107	60	45	14
	3	Int.	□	1250S-DIN-C	107	60	45	14
	5	Int.	□	1250L-DIN	124	77	45	14
	5	Int.	●	1250L-DIN-C	124	77	45	14
	8	Int.	□	1250-L8C	189	140	45	14
	10	Int.	□	1250-L10C	214	165	45	14
	12	Int.	●	1250-L12C	239	190	45	14
	15	Int.	□	1250-L15C	276	227	45	14
	20	Int.	●	1250-L20C	339	290	45	14
12.6	3	Int.	□	1260S-DIN	107	60	45	14
	3	Int.	□	1260S-DIN-C	107	60	45	14
	5	Int.	□	1260L-DIN	124	77	45	14
	5	Int.	□	1260L-DIN-C	124	77	45	14
	8	Int.	□	1260-L8C	194	145	45	14
	10	Int.	□	1260-L10C	220	171	45	14
	12	Int.	□	1260-L12C	246	197	45	14
	15	Int.	□	1260-L15C	285	236	45	14
	20	Int.	□	1260-L20C	350	301	45	14
12.7	3	Int.	□	1270S-DIN	107	60	45	14
	3	Int.	□	1270S-DIN-C	107	60	45	14
	5	Int.	□	1270L-DIN	124	77	45	14
	5	Int.	□	1270L-DIN-C	124	77	45	14
	8	Int.	□	1270-L8C	194	145	45	14
	10	Int.	□	1270-L10C	220	171	45	14
	12	Int.	□	1270-L12C	246	197	45	14
	15	Int.	□	1270-L15C	285	236	45	14
	20	Int.	□	1270-L20C	350	301	45	14

MNS DRILLS



Ø 11.8 ~ 12.7



DRILLING (SOLID CARBIDE)

MNS



P	M	K	S	N	H
---	---	---	---	---	---

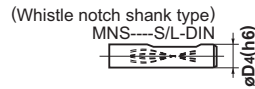
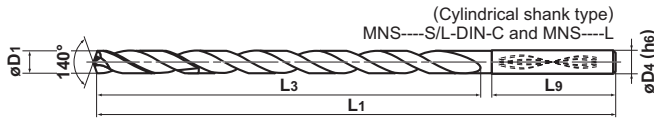

■ MNS○○○○S/L-DIN, MNS○○○○S/L-DIN-C Type

D1	3.0<D1≤6.0	6.0<D1≤10.0	10.0<D1≤18.0	18.0<D1≤20.0
Tolerance	+0.016 +0.004	+0.021 +0.006	+0.025 +0.007	+0.029 +0.008

■ MNS○○○○L-OC, MNS○○○○L-OC Type

D1	D1≤3.0	3.0<D1≤6.0	6.0<D1≤10.0	10.0<D1≤18.0	18.0<D1≤20.0
Tolerance	0 -0.014	0 -0.018	0 -0.022	0 -0.027	0 -0.033

(Note) MNS type can be used for shrink fit holders.

Drill Dia. D1 (mm)	Hole Depth (l/d)	Coolant (Int./Ext.)	Stock TF15	Order Number	Dimensions (mm)			
					L1	L3	L9	D4
12.8	3	Int.	□	MNS1280S-DIN	107	60	45	14
	3	Int.	□	1280S-DIN-C	107	60	45	14
	5	Int.	□	1280L-DIN	124	77	45	14
	5	Int.	□	1280L-DIN-C	124	77	45	14
	8	Int.	□	1280-L8C	194	145	45	14
	10	Int.	□	1280-L10C	220	171	45	14
	12	Int.	□	1280-L12C	246	197	45	14
	15	Int.	□	1280-L15C	285	236	45	14
20	Int.	□	1280-L20C	350	301	45	14	
12.9	3	Int.	□	1290S-DIN	107	60	45	14
	3	Int.	□	1290S-DIN-C	107	60	45	14
	5	Int.	□	1290L-DIN	124	77	45	14
	5	Int.	□	1290L-DIN-C	124	77	45	14
	8	Int.	□	1290-L8C	194	145	45	14
	10	Int.	□	1290-L10C	220	171	45	14
	12	Int.	□	1290-L12C	246	197	45	14
	15	Int.	□	1290-L15C	285	236	45	14
20	Int.	□	1290-L20C	350	301	45	14	
13.0	3	Int.	□	1300S-DIN	107	60	45	14
	3	Int.	□	1300S-DIN-C	107	60	45	14
	5	Int.	□	1300L-DIN	124	77	45	14
	5	Int.	●	1300L-DIN-C	124	77	45	14
	8	Int.	□	1300-L8C	194	145	45	14
	10	Int.	□	1300-L10C	220	171	45	14
	12	Int.	●	1300-L12C	246	197	45	14
	15	Int.	□	1300-L15C	285	236	45	14
20	Int.	●	1300-L20C	350	301	45	14	
13.1	3	Int.	□	1310S-DIN	107	60	45	14
	3	Int.	□	1310S-DIN-C	107	60	45	14
	5	Int.	□	1310L-DIN	124	77	45	14
	5	Int.	□	1310L-DIN-C	124	77	45	14
	8	Int.	□	1310-L8C	200	151	45	14
	10	Int.	□	1310-L10C	227	178	45	14
	12	Int.	□	1310-L12C	254	205	45	14
	15	Int.	□	1310-L15C	294	245	45	14
20	Int.	□	1310-L20C	362	313	45	14	

Drill Dia. D1 (mm)	Hole Depth (l/d)	Coolant (Int./Ext.)	Stock TF15	Order Number	Dimensions (mm)			
					L1	L3	L9	D4
13.2	3	Int.	□	MNS1320S-DIN	107	60	45	14
	3	Int.	□	1320S-DIN-C	107	60	45	14
	5	Int.	□	1320L-DIN	124	77	45	14
	5	Int.	□	1320L-DIN-C	124	77	45	14
	8	Int.	□	1320-L8C	200	151	45	14
	10	Int.	□	1320-L10C	227	178	45	14
	12	Int.	□	1320-L12C	254	205	45	14
	15	Int.	□	1320-L15C	294	245	45	14
20	Int.	□	1320-L20C	362	313	45	14	
13.3	3	Int.	□	1330S-DIN	107	60	45	14
	3	Int.	□	1330S-DIN-C	107	60	45	14
	5	Int.	□	1330L-DIN	124	77	45	14
	5	Int.	□	1330L-DIN-C	124	77	45	14
	8	Int.	□	1330-L8C	200	151	45	14
	10	Int.	□	1330-L10C	227	178	45	14
	12	Int.	□	1330-L12C	254	205	45	14
	15	Int.	□	1330-L15C	294	245	45	14
20	Int.	□	1330-L20C	362	313	45	14	
13.4	3	Int.	□	1340S-DIN	107	60	45	14
	3	Int.	□	1340S-DIN-C	107	60	45	14
	5	Int.	□	1340L-DIN	124	77	45	14
	5	Int.	□	1340L-DIN-C	124	77	45	14
	8	Int.	□	1340-L8C	200	151	45	14
	10	Int.	□	1340-L10C	227	178	45	14
	12	Int.	□	1340-L12C	254	205	45	14
	15	Int.	□	1340-L15C	294	245	45	14
20	Int.	□	1340-L20C	362	313	45	14	
13.5	3	Int.	□	1350S-DIN	107	60	45	14
	3	Int.	□	1350S-DIN-C	107	60	45	14
	5	Int.	□	1350L-DIN	124	77	45	14
	5	Int.	□	1350L-DIN-C	124	77	45	14
	8	Int.	□	1350-L8C	200	151	45	14
	10	Int.	□	1350-L10C	227	178	45	14
	12	Int.	□	1350-L12C	254	205	45	14
	15	Int.	□	1350-L15C	294	245	45	14
20	Int.	□	1350-L20C	362	313	45	14	

(Note) Please contact Mitsubishi Carbide for any geometry that is not in the brochure (e.g. different diameter and length).

- : Stock Standard
- ★ : Stock Standard in Japan.
- : Non stock, produced to order only

Drill Dia. D1 (mm)	Hole Depth (l/d)	Coolant (Int./Ext.)	Stock TF15	Order Number	Dimensions (mm)			
					L1	L3	L9	D4
13.6	3	Int.	□	MNS1360S-DIN	107	60	45	14
	3	Int.	□	1360S-DIN-C	107	60	45	14
	5	Int.	□	1360L-DIN	124	77	45	14
	5	Int.	□	1360L-DIN-C	124	77	45	14
	8	Int.	□	1360-L8C	205	156	45	14
	10	Int.	□	1360-L10C	233	184	45	14
	12	Int.	□	1360-L12C	261	212	45	14
	15	Int.	□	1360-L15C	303	254	45	14
20	Int.	□	1360-L20C	373	324	45	14	
13.7	3	Int.	□	1370S-DIN	107	60	45	14
	3	Int.	□	1370S-DIN-C	107	60	45	14
	5	Int.	□	1370L-DIN	124	77	45	14
	5	Int.	□	1370L-DIN-C	124	77	45	14
	8	Int.	□	1370-L8C	205	156	45	14
	10	Int.	□	1370-L10C	233	184	45	14
	12	Int.	□	1370-L12C	261	212	45	14
	15	Int.	□	1370-L15C	303	254	45	14
20	Int.	□	1370-L20C	373	324	45	14	
13.8	3	Int.	□	1380S-DIN	107	60	45	14
	3	Int.	□	1380S-DIN-C	107	60	45	14
	5	Int.	□	1380L-DIN	124	77	45	14
	5	Int.	□	1380L-DIN-C	124	77	45	14
	8	Int.	□	1380-L8C	205	156	45	14
	10	Int.	□	1380-L10C	233	184	45	14
	12	Int.	□	1380-L12C	261	212	45	14
	15	Int.	□	1380-L15C	303	254	45	14
20	Int.	□	1380-L20C	373	324	45	14	
13.9	3	Int.	□	1390S-DIN	107	60	45	14
	3	Int.	□	1390S-DIN-C	107	60	45	14
	5	Int.	□	1390L-DIN	124	77	45	14
	5	Int.	□	1390L-DIN-C	124	77	45	14
	8	Int.	□	1390-L8C	205	156	45	14
	10	Int.	□	1390-L10C	233	184	45	14
	12	Int.	□	1390-L12C	261	212	45	14
	15	Int.	□	1390-L15C	303	254	45	14
20	Int.	□	1390-L20C	373	324	45	14	
14.0	3	Int.	□	1400S-DIN	107	60	45	14
	3	Int.	□	1400S-DIN-C	107	60	45	14
	5	Int.	□	1400L-DIN	124	77	45	14
	5	Int.	●	1400L-DIN-C	124	77	45	14
	8	Int.	□	1400-L8C	205	156	45	14
	10	Int.	□	1400-L10C	233	184	45	14
	12	Int.	●	1400-L12C	261	212	45	14
	15	Int.	□	1400-L15C	303	254	45	14
20	Int.	●	1400-L20C	373	324	45	14	
14.1	3	Int.	□	1410S-DIN	114	64	48	16
	3	Int.	□	1410S-DIN-C	114	64	48	16
	5	Int.	□	1410L-DIN	132	82	48	16
	5	Int.	□	1410L-DIN-C	132	82	48	16
14.2	3	Int.	□	1420S-DIN	114	64	48	16
	3	Int.	□	1420S-DIN-C	114	64	48	16
	5	Int.	□	1420L-DIN	132	82	48	16
	5	Int.	●	1420L-DIN-C	132	82	48	16

Drill Dia. D1 (mm)	Hole Depth (l/d)	Coolant (Int./Ext.)	Stock TF15	Order Number	Dimensions (mm)			
					L1	L3	L9	D4
14.3	3	Int.	□	MNS1430S-DIN	114	64	48	16
	3	Int.	□	1430S-DIN-C	114	64	48	16
	5	Int.	□	1430L-DIN	132	82	48	16
	5	Int.	□	1430L-DIN-C	132	82	48	16
14.4	3	Int.	□	1440S-DIN	114	64	48	16
	3	Int.	□	1440S-DIN-C	114	64	48	16
	5	Int.	□	1440L-DIN	132	82	48	16
	5	Int.	□	1440L-DIN-C	132	82	48	16
14.5	3	Int.	□	1450S-DIN	114	64	48	16
	3	Int.	□	1450S-DIN-C	114	64	48	16
	5	Int.	□	1450L-DIN	132	82	48	16
	5	Int.	□	1450L-DIN-C	132	82	48	16
14.6	3	Int.	□	1460S-DIN	114	64	48	16
	3	Int.	□	1460S-DIN-C	114	64	48	16
	5	Int.	□	1460L-DIN	132	82	48	16
	5	Int.	□	1460L-DIN-C	132	82	48	16
14.7	3	Int.	□	1470S-DIN	114	64	48	16
	3	Int.	□	1470S-DIN-C	114	64	48	16
	5	Int.	□	1470L-DIN	132	82	48	16
	5	Int.	□	1470L-DIN-C	132	82	48	16
14.8	3	Int.	□	1480S-DIN	114	64	48	16
	3	Int.	□	1480S-DIN-C	114	64	48	16
	5	Int.	□	1480L-DIN	132	82	48	16
	5	Int.	□	1480L-DIN-C	132	82	48	16
14.9	3	Int.	□	1490S-DIN	114	64	48	16
	3	Int.	□	1490S-DIN-C	114	64	48	16
	5	Int.	□	1490L-DIN	132	82	48	16
	5	Int.	□	1490L-DIN-C	132	82	48	16
15.0	3	Int.	□	1500S-DIN	114	64	48	16
	3	Int.	□	1500S-DIN-C	114	64	48	16
	5	Int.	□	1500L-DIN	132	82	48	16
	5	Int.	●	1500L-DIN-C	132	82	48	16
15.1	3	Int.	□	1510S-DIN	115	65	48	16
	3	Int.	□	1510S-DIN-C	115	65	48	16
	5	Int.	□	1510L-DIN	133	83	48	16
	5	Int.	□	1510L-DIN-C	133	83	48	16
15.2	3	Int.	□	1520S-DIN	115	65	48	16
	3	Int.	□	1520S-DIN-C	115	65	48	16
	5	Int.	□	1520L-DIN	133	83	48	16
	5	Int.	□	1520L-DIN-C	133	83	48	16
15.3	3	Int.	□	1530S-DIN	115	65	48	16
	3	Int.	□	1530S-DIN-C	115	65	48	16
	5	Int.	□	1530L-DIN	133	83	48	16
	5	Int.	□	1530L-DIN-C	133	83	48	16
15.4	3	Int.	□	1540S-DIN	115	65	48	16
	3	Int.	□	1540S-DIN-C	115	65	48	16
	5	Int.	□	1540L-DIN	133	83	48	16
	5	Int.	□	1540L-DIN-C	133	83	48	16
15.5	3	Int.	□	1550S-DIN	115	65	48	16
	3	Int.	□	1550S-DIN-C	115	65	48	16
	5	Int.	□	1550L-DIN	133	83	48	16
	5	Int.	□	1550L-DIN-C	133	83	48	16

MNS DRILLS



Ø 13.6 ~ 15.5

CUTTING CONDITIONS



D116

D107

DRILLING (SOLID CARBIDE)

MNS



P	M	K	S	N	H
---	---	---	---	---	---

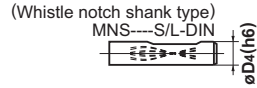
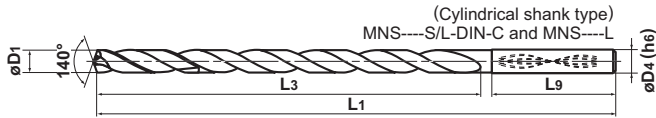

MNS $\odot\odot\odot\odot$ S/L-DIN, MNS $\odot\odot\odot\odot$ S/L-DIN-C Type

D1	3.0<D1≤6.0	6.0<D1≤10.0	10.0<D1≤18.0	18.0<D1≤20.0
Tolerance	+0.016 +0.004	+0.021 +0.006	+0.025 +0.007	+0.029 +0.008

MNS $\odot\odot\odot\odot$ -L $\odot\odot$, MNS $\odot\odot\odot\odot$ -L $\odot\odot$ C Type

D1	D1≤3.0	3.0<D1≤6.0	6.0<D1≤10.0	10.0<D1≤18.0	18.0<D1≤20.0
Tolerance	0 -0.014	0 -0.018	0 -0.022	0 -0.027	0 -0.033

(Note) MNS type can be used for shrink fit holders.

Drill Dia. D1 (mm)	Hole Depth (l/d)	Coolant (Int./Ext.)	Stock TF15	Order Number	Dimensions (mm)			
					L1	L3	L9	D4
15.6	3	Int.	<input type="checkbox"/>	MNS1560S-DIN	115	65	48	16
	3	Int.	<input type="checkbox"/>	1560S-DIN-C	115	65	48	16
	5	Int.	<input type="checkbox"/>	1560L-DIN	133	83	48	16
	5	Int.	<input type="checkbox"/>	1560L-DIN-C	133	83	48	16
15.7	3	Int.	<input type="checkbox"/>	1570S-DIN	115	65	48	16
	3	Int.	<input type="checkbox"/>	1570S-DIN-C	115	65	48	16
	5	Int.	<input type="checkbox"/>	1570L-DIN	133	83	48	16
	5	Int.	<input type="checkbox"/>	1570L-DIN-C	133	83	48	16
15.8	3	Int.	<input type="checkbox"/>	1580S-DIN	115	65	48	16
	3	Int.	<input type="checkbox"/>	1580S-DIN-C	115	65	48	16
	5	Int.	<input type="checkbox"/>	1580L-DIN	133	83	48	16
	5	Int.	<input type="checkbox"/>	1580L-DIN-C	133	83	48	16
15.9	3	Int.	<input type="checkbox"/>	1590S-DIN	115	65	48	16
	3	Int.	<input type="checkbox"/>	1590S-DIN-C	115	65	48	16
	5	Int.	<input type="checkbox"/>	1590L-DIN	133	83	48	16
	5	Int.	<input type="checkbox"/>	1590L-DIN-C	133	83	48	16
16.0	3	Int.	<input type="checkbox"/>	1600S-DIN	115	65	48	16
	3	Int.	<input type="checkbox"/>	1600S-DIN-C	115	65	48	16
	5	Int.	<input type="checkbox"/>	1600L-DIN	133	83	48	16
	5	Int.	<input checked="" type="checkbox"/>	1600L-DIN-C	133	83	48	16
16.1	3	Int.	<input type="checkbox"/>	1610S-DIN	123	73	48	18
	3	Int.	<input type="checkbox"/>	1610S-DIN-C	123	73	48	18
	5	Int.	<input type="checkbox"/>	1610L-DIN	143	93	48	18
	5	Int.	<input type="checkbox"/>	1610L-DIN-C	143	93	48	18
16.2	3	Int.	<input type="checkbox"/>	1620S-DIN	123	73	48	18
	3	Int.	<input type="checkbox"/>	1620S-DIN-C	123	73	48	18
	5	Int.	<input type="checkbox"/>	1620L-DIN	143	93	48	18
	5	Int.	<input type="checkbox"/>	1620L-DIN-C	143	93	48	18
16.3	3	Int.	<input type="checkbox"/>	1630S-DIN	123	73	48	18
	3	Int.	<input type="checkbox"/>	1630S-DIN-C	123	73	48	18
	5	Int.	<input type="checkbox"/>	1630L-DIN	143	93	48	18
	5	Int.	<input type="checkbox"/>	1630L-DIN-C	143	93	48	18
16.4	3	Int.	<input type="checkbox"/>	1640S-DIN	123	73	48	18
	3	Int.	<input type="checkbox"/>	1640S-DIN-C	123	73	48	18
	5	Int.	<input type="checkbox"/>	1640L-DIN	143	93	48	18
	5	Int.	<input type="checkbox"/>	1640L-DIN-C	143	93	48	18
16.5	3	Int.	<input type="checkbox"/>	1650S-DIN	123	73	48	18
	3	Int.	<input type="checkbox"/>	1650S-DIN-C	123	73	48	18
	5	Int.	<input type="checkbox"/>	1650L-DIN	143	93	48	18
	5	Int.	<input type="checkbox"/>	1650L-DIN-C	143	93	48	18

Drill Dia. D1 (mm)	Hole Depth (l/d)	Coolant (Int./Ext.)	Stock TF15	Order Number	Dimensions (mm)			
					L1	L3	L9	D4
16.6	3	Int.	<input type="checkbox"/>	MNS1660S-DIN	123	73	48	18
	3	Int.	<input type="checkbox"/>	1660S-DIN-C	123	73	48	18
	5	Int.	<input type="checkbox"/>	1660L-DIN	143	93	48	18
	5	Int.	<input type="checkbox"/>	1660L-DIN-C	143	93	48	18
16.7	3	Int.	<input type="checkbox"/>	1670S-DIN	123	73	48	18
	3	Int.	<input type="checkbox"/>	1670S-DIN-C	123	73	48	18
	5	Int.	<input type="checkbox"/>	1670L-DIN	143	93	48	18
	5	Int.	<input type="checkbox"/>	1670L-DIN-C	143	93	48	18
16.8	3	Int.	<input type="checkbox"/>	1680S-DIN	123	73	48	18
	3	Int.	<input type="checkbox"/>	1680S-DIN-C	123	73	48	18
	5	Int.	<input type="checkbox"/>	1680L-DIN	143	93	48	18
	5	Int.	<input type="checkbox"/>	1680L-DIN-C	143	93	48	18
16.9	3	Int.	<input type="checkbox"/>	1690S-DIN	123	73	48	18
	3	Int.	<input type="checkbox"/>	1690S-DIN-C	123	73	48	18
	5	Int.	<input type="checkbox"/>	1690L-DIN	143	93	48	18
	5	Int.	<input type="checkbox"/>	1690L-DIN-C	143	93	48	18
17.0	3	Int.	<input type="checkbox"/>	1700S-DIN	123	73	48	18
	3	Int.	<input type="checkbox"/>	1700S-DIN-C	123	73	48	18
	5	Int.	<input type="checkbox"/>	1700L-DIN	143	93	48	18
	5	Int.	<input checked="" type="checkbox"/>	1700L-DIN-C	143	93	48	18
17.1	3	Int.	<input type="checkbox"/>	1710S-DIN	123	73	48	18
	3	Int.	<input type="checkbox"/>	1710S-DIN-C	123	73	48	18
	5	Int.	<input type="checkbox"/>	1710L-DIN	143	93	48	18
	5	Int.	<input type="checkbox"/>	1710L-DIN-C	143	93	48	18
17.2	3	Int.	<input type="checkbox"/>	1720S-DIN	123	73	48	18
	3	Int.	<input type="checkbox"/>	1720S-DIN-C	123	73	48	18
	5	Int.	<input type="checkbox"/>	1720L-DIN	143	93	48	18
	5	Int.	<input type="checkbox"/>	1720L-DIN-C	143	93	48	18
17.3	3	Int.	<input type="checkbox"/>	1730S-DIN	123	73	48	18
	3	Int.	<input type="checkbox"/>	1730S-DIN-C	123	73	48	18
	5	Int.	<input type="checkbox"/>	1730L-DIN	143	93	48	18
	5	Int.	<input type="checkbox"/>	1730L-DIN-C	143	93	48	18
17.4	3	Int.	<input type="checkbox"/>	1740S-DIN	123	73	48	18
	3	Int.	<input type="checkbox"/>	1740S-DIN-C	123	73	48	18
	5	Int.	<input type="checkbox"/>	1740L-DIN	143	93	48	18
	5	Int.	<input type="checkbox"/>	1740L-DIN-C	143	93	48	18
17.5	3	Int.	<input type="checkbox"/>	1750S-DIN	123	73	48	18
	3	Int.	<input type="checkbox"/>	1750S-DIN-C	123	73	48	18
	5	Int.	<input type="checkbox"/>	1750L-DIN	143	93	48	18
	5	Int.	<input checked="" type="checkbox"/>	1750L-DIN-C	143	93	48	18

● : Stock Standard
 ★ : Stock Standard in Japan.
 : Non stock, produced to order only

Drill Dia. D1 (mm)	Hole Depth (l/d)	Coolant (Int./Ext.)	Stock TF15	Order Number	Dimensions (mm)			
					L1	L3	L9	D4
17.6	3	Int.	□	MNS1760S-DIN	123	73	48	18
	3	Int.	□	1760S-DIN-C	123	73	48	18
	5	Int.	□	1760L-DIN	143	93	48	18
	5	Int.	□	1760L-DIN-C	143	93	48	18
17.7	3	Int.	□	1770S-DIN	123	73	48	18
	3	Int.	□	1770S-DIN-C	123	73	48	18
	5	Int.	□	1770L-DIN	143	93	48	18
	5	Int.	□	1770L-DIN-C	143	93	48	18
17.8	3	Int.	□	1780S-DIN	123	73	48	18
	3	Int.	□	1780S-DIN-C	123	73	48	18
	5	Int.	□	1780L-DIN	143	93	48	18
	5	Int.	□	1780L-DIN-C	143	93	48	18
17.9	3	Int.	□	1790S-DIN	123	73	48	18
	3	Int.	□	1790S-DIN-C	123	73	48	18
	5	Int.	□	1790L-DIN	143	93	48	18
	5	Int.	□	1790L-DIN-C	143	93	48	18
18.0	3	Int.	□	1800S-DIN	123	73	48	18
	3	Int.	□	1800S-DIN-C	123	73	48	18
	5	Int.	□	1800L-DIN	143	93	48	18
	5	Int.	●	1800L-DIN-C	143	93	48	18
18.1	3	Int.	□	1810S-DIN	131	79	50	20
	3	Int.	□	1810S-DIN-C	131	79	50	20
	5	Int.	□	1810L-DIN	153	101	50	20
	5	Int.	□	1810L-DIN-C	153	101	50	20
18.2	3	Int.	□	1820S-DIN	131	79	50	20
	3	Int.	□	1820S-DIN-C	131	79	50	20
	5	Int.	□	1820L-DIN	153	101	50	20
	5	Int.	□	1820L-DIN-C	153	101	50	20
18.3	3	Int.	□	1830S-DIN	131	79	50	20
	3	Int.	□	1830S-DIN-C	131	79	50	20
	5	Int.	□	1830L-DIN	153	101	50	20
	5	Int.	□	1830L-DIN-C	153	101	50	20
18.4	3	Int.	□	1840S-DIN	131	79	50	20
	3	Int.	□	1840S-DIN-C	131	79	50	20
	5	Int.	□	1840L-DIN	153	101	50	20
	5	Int.	□	1840L-DIN-C	153	101	50	20
18.5	3	Int.	□	1850S-DIN	131	79	50	20
	3	Int.	□	1850S-DIN-C	131	79	50	20
	5	Int.	□	1850L-DIN	153	101	50	20
	5	Int.	□	1850L-DIN-C	153	101	50	20
18.6	3	Int.	□	1860S-DIN	131	79	50	20
	3	Int.	□	1860S-DIN-C	131	79	50	20
	5	Int.	□	1860L-DIN	153	101	50	20
	5	Int.	□	1860L-DIN-C	153	101	50	20
18.7	3	Int.	□	1870S-DIN	131	79	50	20
	3	Int.	□	1870S-DIN-C	131	79	50	20
	5	Int.	□	1870L-DIN	153	101	50	20
	5	Int.	□	1870L-DIN-C	153	101	50	20
18.8	3	Int.	□	1880S-DIN	131	79	50	20
	3	Int.	□	1880S-DIN-C	131	79	50	20
	5	Int.	□	1880L-DIN	153	101	50	20
	5	Int.	□	1880L-DIN-C	153	101	50	20

Drill Dia. D1 (mm)	Hole Depth (l/d)	Coolant (Int./Ext.)	Stock TF15	Order Number	Dimensions (mm)			
					L1	L3	L9	D4
18.9	3	Int.	□	MNS1890S-DIN	131	79	50	20
	3	Int.	□	1890S-DIN-C	131	79	50	20
	5	Int.	□	1890L-DIN	153	101	50	20
	5	Int.	□	1890L-DIN-C	153	101	50	20
19.0	3	Int.	□	1900S-DIN	131	79	50	20
	3	Int.	□	1900S-DIN-C	131	79	50	20
	5	Int.	□	1900L-DIN	153	101	50	20
	5	Int.	□	1900L-DIN-C	153	101	50	20
19.1	3	Int.	□	1910S-DIN	131	79	50	20
	3	Int.	□	1910S-DIN-C	131	79	50	20
	5	Int.	□	1910L-DIN	153	101	50	20
	5	Int.	□	1910L-DIN-C	153	101	50	20
19.2	3	Int.	□	1920S-DIN	131	79	50	20
	3	Int.	□	1920S-DIN-C	131	79	50	20
	5	Int.	□	1920L-DIN	153	101	50	20
	5	Int.	□	1920L-DIN-C	153	101	50	20
19.3	3	Int.	□	1930S-DIN	131	79	50	20
	3	Int.	□	1930S-DIN-C	131	79	50	20
	5	Int.	□	1930L-DIN	153	101	50	20
	5	Int.	□	1930L-DIN-C	153	101	50	20
19.4	3	Int.	□	1940S-DIN	131	79	50	20
	3	Int.	□	1940S-DIN-C	131	79	50	20
	5	Int.	□	1940L-DIN	153	101	50	20
	5	Int.	□	1940L-DIN-C	153	101	50	20
19.5	3	Int.	□	1950S-DIN	131	79	50	20
	3	Int.	□	1950S-DIN-C	131	79	50	20
	5	Int.	□	1950L-DIN	153	101	50	20
	5	Int.	□	1950L-DIN-C	153	101	50	20
19.6	3	Int.	□	1960S-DIN	131	79	50	20
	3	Int.	□	1960S-DIN-C	131	79	50	20
	5	Int.	□	1960L-DIN	153	101	50	20
	5	Int.	□	1960L-DIN-C	153	101	50	20
19.7	3	Int.	□	1970S-DIN	131	79	50	20
	3	Int.	□	1970S-DIN-C	131	79	50	20
	5	Int.	□	1970L-DIN	153	101	50	20
	5	Int.	□	1970L-DIN-C	153	101	50	20
19.8	3	Int.	□	1980S-DIN	131	79	50	20
	3	Int.	□	1980S-DIN-C	131	79	50	20
	5	Int.	□	1980L-DIN	153	101	50	20
	5	Int.	□	1980L-DIN-C	153	101	50	20
19.9	3	Int.	□	1990S-DIN	131	79	50	20
	3	Int.	□	1990S-DIN-C	131	79	50	20
	5	Int.	□	1990L-DIN	153	101	50	20
	5	Int.	□	1990L-DIN-C	153	101	50	20
20.0	3	Int.	□	2000S-DIN	131	79	50	20
	3	Int.	□	2000S-DIN-C	131	79	50	20
	5	Int.	□	2000L-DIN	153	101	50	20
	5	Int.	●	2000L-DIN-C	153	101	50	20

DRILLING (SOLID CARBIDE)

MNS



P	M	K	S	N	<input checked="" type="checkbox"/> H
---	---	---	---	---	---------------------------------------

■ MNS○○○○LB, MNS○○○○DB Type

D1	D1≤3.0	3.0<D1≤6.0	6.0<D1≤10.0	10.0<D1≤14.0
Tolerance	0 -0.014	0 -0.018	0 -0.022	0 -0.027

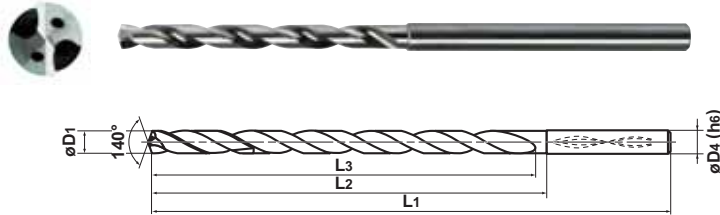

(Note 1) 4.5 or smaller diameter drills are designed with 2 coolant holes.

(Note 2) MNS type can be used for shrink fit holders.

DRILLING | MNS DRILLS (JAPAN STANDARD)

Drill Dia. D1 (mm)	Hole Depth (l/d)	Coolant (Int./Ext.)	Stock TF15	Order Number	Dimensions (mm)			
					L3	L2	L1	D4
3.0	5	Int.	★	MNS0300LB	33	33	81	3
	10	Int.	★	0300X10DB	39	42	90	3
	20	Int.	★	0300X20DB	69	72	120	3
	30	Int.	★	0300X30DB	99	102	150	3
3.1	5	Int.	★	0310LB	39	39	87	4
	10	Int.	□	0310X10DB	46	49	97	4
	20	Int.	□	0310X20DB	81	84	132	4
	30	Int.	□	0310X30DB	116	119	167	4
3.2	5	Int.	★	0320LB	39	39	87	4
	10	Int.	★	0320X10DB	46	49	97	4
	20	Int.	★	0320X20DB	81	84	132	4
	30	Int.	★	0320X30DB	116	119	167	4
3.3	5	Int.	★	0330LB	39	39	87	4
	10	Int.	□	0330X10DB	46	49	97	4
	20	Int.	□	0330X20DB	81	84	132	4
	30	Int.	□	0330X30DB	116	119	167	4
3.4	5	Int.	★	0340LB	39	39	87	4
	10	Int.	★	0340X10DB	46	49	97	4
	20	Int.	★	0340X20DB	81	84	132	4
	30	Int.	★	0340X30DB	116	119	167	4
3.5	5	Int.	★	0350LB	39	39	87	4
	10	Int.	□	0350X10DB	46	49	97	4
	20	Int.	□	0350X20DB	81	84	132	4
	30	Int.	□	0350X30DB	116	119	167	4
3.6	5	Int.	★	0360LB	44	44	92	4
	10	Int.	★	0360X10DB	52	55	103	4
	20	Int.	★	0360X20DB	92	95	143	4
	30	Int.	★	0360X30DB	132	135	183	4
3.7	5	Int.	★	0370LB	44	44	92	4
	10	Int.	□	0370X10DB	52	55	103	4
	20	Int.	□	0370X20DB	92	95	143	4
	30	Int.	□	0370X30DB	132	135	183	4

Drill Dia. D1 (mm)	Hole Depth (l/d)	Coolant (Int./Ext.)	Stock TF15	Order Number	Dimensions (mm)			
					L3	L2	L1	D4
3.8	5	Int.	★	MNS0380LB	44	44	92	4
	10	Int.	□	0380X10DB	52	55	103	4
	20	Int.	□	0380X20DB	92	95	143	4
	30	Int.	□	0380X30DB	132	135	183	4
3.9	5	Int.	★	0390LB	44	44	92	4
	10	Int.	★	0390X10DB	52	55	103	4
	20	Int.	★	0390X20DB	92	95	143	4
	30	Int.	★	0390X30DB	132	135	183	4
4.0	5	Int.	★	0400LB	44	44	92	4
	10	Int.	★	0400X10DB	52	55	103	4
	20	Int.	★	0400X20DB	92	95	143	4
	30	Int.	★	0400X30DB	132	135	183	4
4.1	5	Int.	★	0410LB	50	50	100	5
	10	Int.	□	0410X10DB	59	62	112	5
	20	Int.	□	0410X20DB	104	107	157	5
	30	Int.	□	0410X30DB	149	152	202	5
4.2	5	Int.	★	0420LB	50	50	100	5
	10	Int.	□	0420X10DB	59	62	112	5
	20	Int.	□	0420X20DB	104	107	157	5
	30	Int.	□	0420X30DB	149	152	202	5
4.3	5	Int.	★	0430LB	50	50	100	5
	10	Int.	□	0430X10DB	59	62	112	5
	20	Int.	□	0430X20DB	104	107	157	5
	30	Int.	□	0430X30DB	149	152	202	5
4.4	5	Int.	★	0440LB	50	50	100	5
	10	Int.	□	0440X10DB	59	62	112	5
	20	Int.	□	0440X20DB	104	107	157	5
	30	Int.	□	0440X30DB	149	152	202	5
4.5	5	Int.	★	0450LB	50	50	100	5
	10	Int.	□	0450X10DB	59	62	112	5
	20	Int.	□	0450X20DB	104	107	157	5
	30	Int.	□	0450X30DB	149	152	202	5

(Note) Please contact Mitsubishi Carbide for any geometry that is not in the brochure (e.g. different diameter and length).

- : Stock Standard
- ★ : Stock Standard in Japan.
- : Non stock, produced to order only

Drill Dia. D1 (mm)	Hole Depth (l/d)	Coolant (Int./Ext.)	Stock TF15	Order Number	Dimensions (mm)			
					L3	L2	L1	D4
4.6	5	Int.	★	MNS0460LB	55	55	105	5
	10	Int.	□	0460X10DB	65	68	118	5
	20	Int.	□	0460X20DB	115	118	168	5
	30	Int.	□	0460X30DB	165	168	218	5
4.7	5	Int.	★	0470LB	55	55	105	5
	10	Int.	□	0470X10DB	65	68	118	5
	20	Int.	□	0470X20DB	115	118	168	5
	30	Int.	□	0470X30DB	165	168	218	5
4.8	5	Int.	★	0480LB	55	55	105	5
	10	Int.	□	0480X10DB	65	68	118	5
	20	Int.	□	0480X20DB	115	118	168	5
	30	Int.	□	0480X30DB	165	168	218	5
4.9	5	Int.	★	0490LB	55	55	105	5
	10	Int.	★	0490X10DB	65	68	118	5
	20	Int.	★	0490X20DB	115	118	168	5
	30	Int.	★	0490X30DB	165	168	218	5
5.0	5	Int.	★	0500LB	44	44	100	6
	10	Int.	★	0500X10DB	65	68	118	5
	20	Int.	★	0500X20DB	115	118	168	5
	30	Int.	★	0500X30DB	165	168	218	5
5.1	5	Int.	★	0510LB	44	44	100	6
	10	Int.	★	0510X10DB	72	75	127	6
	20	Int.	★	0510X20DB	127	130	182	6
	30	Int.	★	0510X30DB	182	185	237	6
5.2	5	Int.	★	0520LB	44	44	100	6
	10	Int.	□	0520X10DB	72	75	127	6
	20	Int.	□	0520X20DB	127	130	182	6
	30	Int.	□	0520X30DB	182	185	237	6
5.3	5	Int.	★	0530LB	44	44	100	6
	10	Int.	□	0530X10DB	72	75	127	6
	20	Int.	□	0530X20DB	127	130	182	6
	30	Int.	□	0530X30DB	182	185	237	6
5.4	5	Int.	★	0540LB	44	44	100	6
	10	Int.	□	0540X10DB	72	75	127	6
	20	Int.	□	0540X20DB	127	130	182	6
	30	Int.	□	0540X30DB	182	185	237	6

Drill Dia. D1 (mm)	Hole Depth (l/d)	Coolant (Int./Ext.)	Stock TF15	Order Number	Dimensions (mm)			
					L3	L2	L1	D4
5.5	5	Int.	★	MNS0550LB	44	44	100	6
	10	Int.	★	0550X10DB	72	75	127	6
	20	Int.	★	0550X20DB	127	130	182	6
	30	Int.	★	0550X30DB	182	185	237	6
5.6	5	Int.	★	0560LB	48	48	100	6
	10	Int.	□	0560X10DB	78	81	133	6
	20	Int.	□	0560X20DB	138	141	193	6
	30	Int.	□	0560X30DB	198	201	253	6
5.7	5	Int.	★	0570LB	48	48	100	6
	10	Int.	□	0570X10DB	78	81	133	6
	20	Int.	□	0570X20DB	138	141	193	6
	30	Int.	□	0570X30DB	198	201	253	6
5.8	5	Int.	★	0580LB	48	48	100	6
	10	Int.	□	0580X10DB	78	81	133	6
	20	Int.	□	0580X20DB	138	141	193	6
	30	Int.	□	0580X30DB	198	201	253	6
5.9	5	Int.	★	0590LB	48	48	100	6
	10	Int.	□	0590X10DB	78	81	133	6
	20	Int.	□	0590X20DB	138	141	193	6
	30	Int.	□	0590X30DB	198	201	253	6
6.0	5	Int.	★	0600LB	48	48	100	6
	10	Int.	★	0600X10DB	78	81	133	6
	20	Int.	★	0600X20DB	138	141	193	6
	30	Int.	★	0600X30DB	198	201	253	6
6.1	5	Int.	★	0610LB	52	52	109	7
	10	Int.	★	0610X10DB	85	88	141	7
	20	Int.	★	0610X20DB	150	153	206	7
	30	Int.	★	0610X30DB	215	218	271	7
6.2	5	Int.	★	0620LB	52	52	109	7
	10	Int.	□	0620X10DB	85	88	141	7
	20	Int.	□	0620X20DB	150	153	206	7
	30	Int.	□	0620X30DB	215	218	271	7
6.3	5	Int.	★	0630LB	52	52	109	7
	10	Int.	□	0630X10DB	85	88	141	7
	20	Int.	□	0630X20DB	150	153	206	7
	30	Int.	□	0630X30DB	215	218	271	7

MNS DRILLS (JAPAN STANDARD)

DRILLING

 Ø 4.6 ~ 6.3

DRILLING (SOLID CARBIDE)

MNS



P	M	K	S	N	<input checked="" type="checkbox"/> H
---	---	---	---	---	---------------------------------------

■ MNS○○○○LB, MNS○○○○DB Type

D1	D1≤3.0	3.0<D1≤6.0	6.0<D1≤10.0	10.0<D1≤14.0
Tolerance	0 -0.014	0 -0.018	0 -0.022	0 -0.027

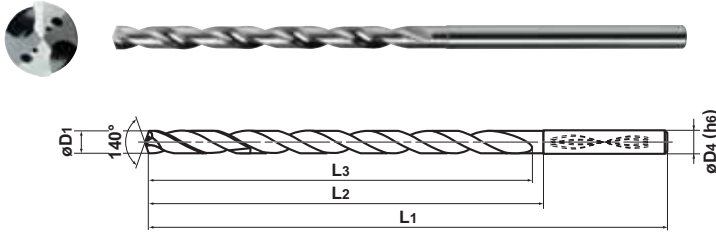

(Note) MNS type can be used for shrink fit holders.

DRILLING | MNS DRILLS (JAPAN STANDARD)

Drill Dia. D1 (mm)	Hole Depth (l/d)	Coolant (Int./Ext.)	Stock TF15	Order Number	Dimensions (mm)			
					L3	L2	L1	D4
6.4	5	Int.	★	MNS0640LB	52	52	109	7
	10	Int.	□	0640X10DB	85	88	141	7
	20	Int.	□	0640X20DB	150	153	206	7
	30	Int.	□	0640X30DB	215	218	271	7
6.5	5	Int.	★	0650LB	52	52	109	7
	10	Int.	★	0650X10DB	85	88	141	7
	20	Int.	★	0650X20DB	150	153	206	7
	30	Int.	★	0650X30DB	215	218	271	7
6.6	5	Int.	★	0660LB	56	56	109	7
	10	Int.	□	0660X10DB	91	94	147	7
	20	Int.	□	0660X20DB	161	164	217	7
	30	Int.	□	0660X30DB	231	234	287	7
6.7	5	Int.	★	0670LB	56	56	109	7
	10	Int.	★	0670X10DB	91	94	147	7
	20	Int.	★	0670X20DB	161	164	217	7
	30	Int.	★	0670X30DB	231	234	287	7
6.8	5	Int.	★	0680LB	56	56	109	7
	10	Int.	□	0680X10DB	91	94	147	7
	20	Int.	□	0680X20DB	161	164	217	7
	30	Int.	□	0680X30DB	231	234	287	7
6.9	5	Int.	★	0690LB	56	56	109	7
	10	Int.	□	0690X10DB	91	94	147	7
	20	Int.	□	0690X20DB	161	164	217	7
	30	Int.	□	0690X30DB	231	234	287	7
7.0	5	Int.	★	0700LB	56	56	109	7
	10	Int.	★	0700X10DB	91	94	147	7
	20	Int.	★	0700X20DB	161	164	217	7
	30	Int.	★	0700X30DB	231	234	287	7
7.1	5	Int.	★	0710LB	60	64	118	8
	10	Int.	□	0710X10DB	98	101	155	8
	20	Int.	□	0710X20DB	173	176	230	8
	30	Int.	□	0710X30DB	248	251	305	8
7.2	5	Int.	★	0720LB	60	64	118	8
	10	Int.	★	0720X10DB	98	101	155	8
	20	Int.	★	0720X20DB	173	176	230	8
	30	Int.	★	0720X30DB	248	251	305	8

Drill Dia. D1 (mm)	Hole Depth (l/d)	Coolant (Int./Ext.)	Stock TF15	Order Number	Dimensions (mm)			
					L3	L2	L1	D4
7.3	5	Int.	★	MNS0730LB	60	64	118	8
	10	Int.	□	0730X10DB	98	101	155	8
	20	Int.	□	0730X20DB	173	176	230	8
	30	Int.	□	0730X30DB	248	251	305	8
7.4	5	Int.	★	0740LB	60	64	118	8
	10	Int.	□	0740X10DB	98	101	155	8
	20	Int.	□	0740X20DB	173	176	230	8
	30	Int.	□	0740X30DB	248	251	305	8
7.5	5	Int.	★	0750LB	60	64	118	8
	10	Int.	□	0750X10DB	98	101	155	8
	20	Int.	□	0750X20DB	173	176	230	8
	30	Int.	□	0750X30DB	248	251	305	8
7.6	5	Int.	★	0760LB	64	64	118	8
	10	Int.	□	0760X10DB	104	107	161	8
	20	Int.	□	0760X20DB	184	187	241	8
	30	Int.	□	0760X30DB	264	267	321	8
7.7	5	Int.	★	0770LB	64	64	118	8
	10	Int.	□	0770X10DB	104	107	161	8
	20	Int.	□	0770X20DB	184	187	241	8
	30	Int.	□	0770X30DB	264	267	321	8
7.8	5	Int.	★	0780LB	64	64	118	8
	10	Int.	★	0780X10DB	104	107	161	8
	20	Int.	★	0780X20DB	184	187	241	8
	30	Int.	★	0780X30DB	264	267	321	8
7.9	5	Int.	★	0790LB	64	64	118	8
	10	Int.	□	0790X10DB	104	107	161	8
	20	Int.	□	0790X20DB	184	187	241	8
	30	Int.	□	0790X30DB	264	267	321	8
8.0	5	Int.	★	0800LB	64	64	118	8
	10	Int.	★	0800X10DB	104	107	161	8
	20	Int.	★	0800X20DB	184	187	241	8
	30	Int.	★	0800X30DB	264	267	321	8
8.1	5	Int.	★	0810LB	68	72	127	9
	10	Int.	□	0810X10DB	111	114	169	9
	20	Int.	□	0810X20DB	196	199	254	9
	30	Int.	□	0810X30DB	281	284	339	9

(Note) Please contact Mitsubishi Carbide for any geometry that is not in the brochure (e.g. different diameter and length).

- : Stock Standard
- ★ : Stock Standard in Japan.
- : Non stock, produced to order only

Drill Dia. D1 (mm)	Hole Depth (l/d)	Coolant (Int./Ext.)	Stock TF15	Order Number	Dimensions (mm)			
					L3	L2	L1	D4
8.2	5	Int.	★	MNS0820LB	68	72	127	9
	10	Int.	□	0820X10DB	111	114	169	9
	20	Int.	□	0820X20DB	196	199	254	9
	30	Int.	□	0820X30DB	281	284	339	9
8.3	5	Int.	★	0830LB	68	72	127	9
	10	Int.	□	0830X10DB	111	114	169	9
	20	Int.	□	0830X20DB	196	199	254	9
	30	Int.	□	0830X30DB	281	284	339	9
8.4	5	Int.	★	0840LB	68	72	127	9
	10	Int.	□	0840X10DB	111	114	169	9
	20	Int.	□	0840X20DB	196	199	254	9
	30	Int.	□	0840X30DB	281	284	339	9
8.5	5	Int.	★	0850LB	68	72	127	9
	10	Int.	□	0850X10DB	111	114	169	9
	20	Int.	□	0850X20DB	196	199	254	9
	30	Int.	□	0850X30DB	281	284	339	9
8.6	5	Int.	★	0860LB	72	72	127	9
	10	Int.	□	0860X10DB	117	120	175	9
	20	Int.	□	0860X20DB	207	210	265	9
	30	Int.	□	0860X30DB	297	300	355	9
8.7	5	Int.	★	0870LB	72	72	127	9
	10	Int.	□	0870X10DB	117	120	175	9
	20	Int.	□	0870X20DB	207	210	265	9
	30	Int.	□	0870X30DB	297	300	355	9
8.8	5	Int.	★	0880LB	72	72	127	9
	10	Int.	□	0880X10DB	117	120	175	9
	20	Int.	□	0880X20DB	207	210	265	9
	30	Int.	□	0880X30DB	297	300	355	9
8.9	5	Int.	★	0890LB	72	72	127	9
	10	Int.	□	0890X10DB	117	120	175	9
	20	Int.	□	0890X20DB	207	210	265	9
	30	Int.	□	0890X30DB	297	300	355	9
9.0	5	Int.	★	0900LB	72	72	127	9
	10	Int.	★	0900X10DB	117	120	175	9
	20	Int.	★	0900X20DB	207	210	265	9
	30	Int.	★	0900X30DB	297	300	355	9
9.1	5	Int.	★	0910LB	76	80	136	10
	10	Int.	□	0910X10DB	124	127	182	10
	20	Int.	□	0910X20DB	219	222	277	10
	30	Int.	□	0910X30DB	314	317	372	10
9.2	5	Int.	★	0920LB	76	80	136	10
	10	Int.	□	0920X10DB	124	127	182	10
	20	Int.	□	0920X20DB	219	222	277	10
	30	Int.	□	0920X30DB	314	317	372	10
9.3	5	Int.	★	0930LB	76	80	136	10
	10	Int.	□	0930X10DB	124	127	182	10
	20	Int.	□	0930X20DB	219	222	277	10
	30	Int.	□	0930X30DB	314	317	372	10

Drill Dia. D1 (mm)	Hole Depth (l/d)	Coolant (Int./Ext.)	Stock TF15	Order Number	Dimensions (mm)			
					L3	L2	L1	D4
9.4	5	Int.	★	MNS0940LB	76	80	136	10
	10	Int.	□	0940X10DB	124	127	182	10
	20	Int.	□	0940X20DB	219	222	277	10
	30	Int.	□	0940X30DB	314	317	372	10
9.5	5	Int.	★	0950LB	76	80	136	10
	10	Int.	□	0950X10DB	124	127	182	10
	20	Int.	□	0950X20DB	219	222	277	10
	30	Int.	□	0950X30DB	314	317	372	10
9.6	5	Int.	★	0960LB	80	80	136	10
	10	Int.	□	0960X10DB	130	133	188	10
	20	Int.	□	0960X20DB	230	233	288	10
	30	Int.	□	0960X30DB	330	333	388	10
9.7	5	Int.	★	0970LB	80	80	136	10
	10	Int.	□	0970X10DB	130	133	188	10
	20	Int.	□	0970X20DB	230	233	288	10
	30	Int.	□	0970X30DB	330	333	388	10
9.8	5	Int.	★	0980LB	80	80	136	10
	10	Int.	★	0980X10DB	130	133	188	10
	20	Int.	★	0980X20DB	230	233	288	10
	30	Int.	★	0980X30DB	330	333	388	10
9.9	5	Int.	★	0990LB	80	80	136	10
	10	Int.	□	0990X10DB	130	133	188	10
	20	Int.	□	0990X20DB	230	233	288	10
	30	Int.	□	0990X30DB	330	333	388	10
10.0	5	Int.	★	1000LB	80	80	136	10
	10	Int.	★	1000X10DB	130	133	188	10
	20	Int.	★	1000X20DB	230	233	288	10
	30	Int.	★	1000X30DB	330	333	388	10
10.1	5	Int.	★	1010LB	84	88	149	11
	10	Int.	□	1010X10DB	137	140	201	11
	20	Int.	□	1010X20DB	242	245	306	11
10.2	5	Int.	★	1020LB	84	88	149	11
	10	Int.	□	1020X10DB	137	140	201	11
	20	Int.	□	1020X20DB	242	245	306	11
10.3	5	Int.	★	1030LB	84	88	149	11
	10	Int.	□	1030X10DB	137	140	201	11
	20	Int.	□	1030X20DB	242	245	306	11
10.4	5	Int.	★	1040LB	84	88	149	11
	10	Int.	□	1040X10DB	137	140	201	11
	20	Int.	□	1040X20DB	242	245	306	11
10.5	5	Int.	★	1050LB	84	88	149	11
	10	Int.	★	1050X10DB	137	140	201	11
	20	Int.	★	1050X20DB	242	245	306	11
10.6	5	Int.	★	1060LB	88	88	149	11
	10	Int.	□	1060X10DB	143	146	207	11
	20	Int.	□	1060X20DB	253	256	317	11

MNS DRILLS (JAPAN STANDARD)



DRILLING (SOLID CARBIDE)

MNS



P M K S N H

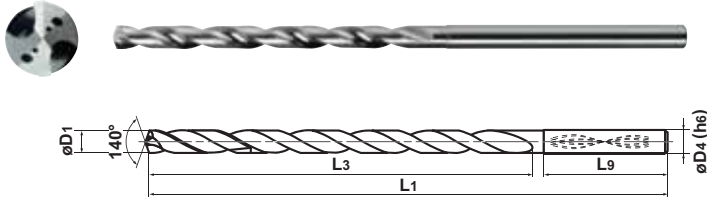

■ MNS○○○○LB, MNS○○○○DB Type

D1	D1≤3.0	3.0<D1≤6.0	6.0<D1≤10.0	10.0<D1≤14.0
Tolerance	0 -0.014	0 -0.018	0 -0.022	0 -0.027

(Note) MNS type can be used for shrink fit holders.

DRILLING MNS DRILLS (JAPAN STANDARD)

Drill Dia. D1 (mm)	Hole Depth (l/d)	Coolant (Int./Ext.)	Stock TF15	Order Number	Dimensions (mm)			
					L1	L3	L9	D4
10.7	5	Int.	★	MNS1070LB	88	88	149	11
	10	Int.	□	1070X10DB	143	146	207	11
	20	Int.	□	1070X20DB	253	256	317	11
10.8	5	Int.	★	1080LB	88	88	149	11
	10	Int.	□	1080X10DB	143	146	207	11
	20	Int.	□	1080X20DB	253	256	317	11
10.9	5	Int.	★	1090LB	88	88	149	11
	10	Int.	□	1090X10DB	143	146	207	11
	20	Int.	□	1090X20DB	253	256	317	11
11.0	5	Int.	★	1100LB	88	88	149	11
	10	Int.	★	1100X10DB	143	146	207	11
	20	Int.	★	1100X20DB	253	256	317	11
11.1	5	Int.	★	1110LB	92	96	158	12
	10	Int.	□	1110X10DB	150	153	215	12
	20	Int.	□	1110X20DB	265	268	330	12
11.2	5	Int.	★	1120LB	92	96	158	12
	10	Int.	□	1120X10DB	150	153	215	12
	20	Int.	□	1120X20DB	265	268	330	12
11.3	5	Int.	★	1130LB	92	96	158	12
	10	Int.	□	1130X10DB	150	153	215	12
	20	Int.	□	1130X20DB	265	268	330	12
11.4	5	Int.	★	1140LB	92	96	158	12
	10	Int.	□	1140X10DB	150	153	215	12
	20	Int.	□	1140X20DB	265	168	330	12
11.5	5	Int.	★	1150LB	92	96	158	12
	10	Int.	□	1150X10DB	150	153	215	12
	20	Int.	□	1150X20DB	265	268	330	12
11.6	5	Int.	★	1160LB	96	96	158	12
	10	Int.	□	1160X10DB	156	159	221	12
	20	Int.	□	1160X20DB	276	279	341	12
11.7	5	Int.	★	1170LB	96	96	158	12
	10	Int.	□	1170X10DB	156	159	221	12
	20	Int.	□	1170X20DB	276	279	341	12
11.8	5	Int.	★	1180LB	96	96	158	12
	10	Int.	□	1180X10DB	156	159	221	12
	20	Int.	□	1180X20DB	276	279	341	12

Drill Dia. D1 (mm)	Hole Depth (l/d)	Coolant (Int./Ext.)	Stock TF15	Order Number	Dimensions (mm)			
					L1	L3	L9	D4
11.9	5	Int.	★	MNS1190LB	96	96	158	12
	10	Int.	□	1190X10DB	156	159	221	12
	20	Int.	□	1190X20DB	276	279	341	12
12.0	5	Int.	★	1200LB	96	96	158	12
	10	Int.	★	1200X10DB	156	159	221	12
	20	Int.	★	1200X20DB	276	279	341	12
12.1	5	Int.	★	1210LB	100	104	167	13
	10	Int.	□	1210X10DB	163	166	229	13
	20	Int.	□	1210X20DB	288	291	354	13
12.2	5	Int.	★	1220LB	100	104	167	13
	10	Int.	□	1220X10DB	163	166	229	13
	20	Int.	□	1220X20DB	288	291	354	13
12.3	5	Int.	★	1230LB	100	104	167	13
	10	Int.	□	1230X10DB	163	166	229	13
	20	Int.	□	1230X20DB	288	291	354	13
12.4	5	Int.	★	1240LB	100	104	167	13
	10	Int.	□	1240X10DB	163	166	229	13
	20	Int.	□	1240X20DB	288	291	354	13
12.5	5	Int.	★	1250LB	100	104	167	13
	10	Int.	□	1250X10DB	163	166	229	13
	20	Int.	□	1250X20DB	288	291	354	13
12.6	5	Int.	★	1260LB	104	104	167	13
	10	Int.	□	1260X10DB	169	172	235	13
	20	Int.	□	1260X20DB	299	302	365	13
12.7	5	Int.	★	1270LB	104	104	167	13
	10	Int.	□	1270X10DB	169	172	235	13
	20	Int.	□	1270X20DB	299	302	365	13
12.8	5	Int.	★	1280LB	104	104	167	13
	10	Int.	□	1280X10DB	169	172	235	13
	20	Int.	□	1280X20DB	299	302	365	13
12.9	5	Int.	★	1290LB	104	104	167	13
	10	Int.	□	1290X10DB	169	172	235	13
	20	Int.	□	1290X20DB	299	302	365	13
13.0	5	Int.	★	1300LB	104	104	167	13
	10	Int.	★	1300X10DB	169	172	235	13
	20	Int.	★	1300X20DB	299	302	365	13

(Note) Please contact Mitsubishi Carbide for any geometry that is not in the brochure (e.g. different diameter and length).

- : Stock Standard
- ★ : Stock Standard in Japan.
- : Non stock, produced to order only

Drill Dia. D1 (mm)	Hole Depth (l/d)	Coolant (Int./Ext.)	Stock TF15	Order Number	Dimensions (mm)			
					L3	L2	L1	D4
13.1	5	Int.	★	MNS1310LB	108	112	176	14
	10	Int.	□	1310X10DB	176	179	243	14
	20	Int.	□	1310X20DB	311	314	378	14
13.2	5	Int.	★	1320LB	108	112	176	14
	10	Int.	□	1320X10DB	176	179	243	14
	20	Int.	□	1320X20DB	311	314	378	14
13.3	5	Int.	★	1330LB	108	112	176	14
	10	Int.	□	1330X10DB	176	179	243	14
	20	Int.	□	1330X20DB	311	314	378	14
13.4	5	Int.	★	1340LB	108	112	176	14
	10	Int.	□	1340X10DB	176	179	243	14
	20	Int.	□	1340X20DB	311	314	378	14
13.5	5	Int.	★	1350LB	108	112	176	14
	10	Int.	□	1350X10DB	176	179	243	14
	20	Int.	□	1350X20DB	311	314	378	14

Drill Dia. D1 (mm)	Hole Depth (l/d)	Coolant (Int./Ext.)	Stock TF15	Order Number	Dimensions (mm)			
					L3	L2	L1	D4
13.6	5	Int.	★	MNS1360LB	112	112	176	14
	10	Int.	□	1360X10DB	182	185	249	14
	20	Int.	□	1360X20DB	322	325	389	14
13.7	5	Int.	★	1370LB	112	112	176	14
	10	Int.	□	1370X10DB	182	185	249	14
	20	Int.	□	1370X20DB	322	325	389	14
13.8	5	Int.	★	1380LB	112	112	176	14
	10	Int.	□	1380X10DB	182	185	249	14
	20	Int.	□	1380X20DB	322	325	389	14
13.9	5	Int.	★	1390LB	112	112	176	14
	10	Int.	□	1390X10DB	182	185	249	14
	20	Int.	□	1390X20DB	322	325	389	14
14.0	5	Int.	★	1400LB	112	112	176	14
	10	Int.	★	1400X10DB	182	185	249	14
	20	Int.	★	1400X20DB	322	325	389	14



RECOMMENDED CUTTING CONDITIONS

MNS Type Drill

Work Material	Drill LengthType	Drill Diameter					
		φ 3.0—φ 6.0		φ 6.0—φ 10.0		φ 10.0—φ 14.0	
		Cutting Speed (m/min)	Feed (mm/rev)	Cutting Speed (m/min)	Feed (mm/rev)	Cutting Speed (m/min)	Feed (mm/rev)
N Aluminium Alloy Casting Aluminium Die Casting	L/D 3, 5, 8	80—150	0.20—0.50	100—200	0.30—1.00	150—250	0.30—1.00
	L/D 10—30	60—120	0.20—0.50	80—150	0.30—1.00	120—200	0.30—1.00
Wrought Aluminium Alloy	L/D 3, 5, 8	80—150	0.15—0.30	100—200	0.20—0.40	150—250	0.20—0.40
	L/D 10—30	60—120	0.15—0.30	80—150	0.20—0.40	120—200	0.20—0.40

Work Material	Drill LengthType	Drill Diameter	
		φ 14.0—φ 20.0	
		Cutting Speed (m/min)	Feed (mm/rev)
N Aluminium Alloy Casting Aluminium Die Casting	L/D 3, 5, 8	150—250	0.30—1.00
	L/D 10—30	—	—
Wrought Aluminium Alloy	L/D 3, 5, 8	150—250	0.30—1.00
	L/D 10—30	—	—

(Note 1) When using a drill with a length over l/d 10, it is necessary to use a pilot hole as a guide.

(If no pilot-hole is used then drill breakage can occur)

(Note 2) For pilot hole drilling, Mitsubishi Materials MNS, MAE-MB or MAS-MB drill is recommended.



HOW TO USE LONG TYPE DRILLS

● Drilling a blind hole

■ 1. Drilling a pilot hole

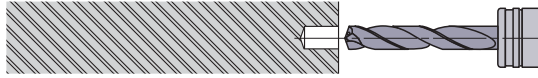

- ① Use a drill with a larger (flatter) point angle than the super long type. Mitsubishi type MNS, MAE-MB or MAS-MB is recommended.
- ② Use a drill with the same diameter as the deep hole drill.
- ③ Drill depth : Approx 2–3D or deeper.
(Adjust the pilot hole depth according to the length of the super long type.)

■ 2. Initial cutting with the long type drill

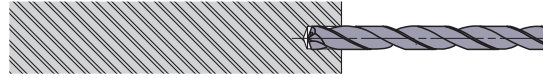

- ① Penetrate the pilot hole at low revolution. (Cutting speed 20–30m/min, feed rate 0.2–0.3mm/rev)
- ② Stop the long type drill 1–3mm short of the pilot hole bottom.

■ 3. Drill the deep hole

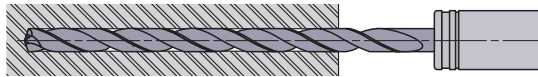

- ① Start cutting at the recommended speed and feed with a non-peck (continuous feed) cycle.

■ 4. Drill retraction

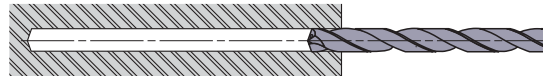

- ① After drilling, lower the cutting revolution about 1–2mm short of the hole end. (Cutting speed of around 20–30m/min)
- ② Retract the drill to the pilot hole depth starting point at a feed rate of 3000mm/min.
- ③ Finally, clear the hole at a cutting speed of 20–30m/min and feed rate of 0.2–0.3mm/rev.

● Drilling and breaking through on irregular faces or angles

■ 1. Spot facing

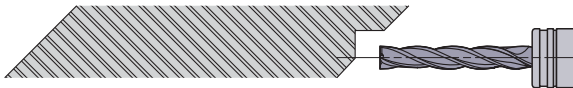

- ① Machine a flat or the irregular face by using an end mill or slot drill capable of spot facing. Make the spot face diameter the same size as the required deep hole diameter.

■ 2. Drilling a pilot hole

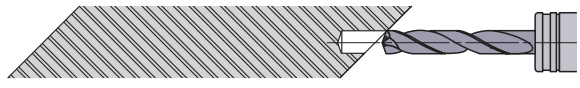

- ① Use a drill with a larger (flatter) point angle than the super long type. Mitsubishi type MNS, MAE-MB or MAS-MB is recommended.
- ② Use a drill with the same diameter as the deep hole drill.
- ③ Drill depth : Approx 2–3D or deeper.
(Adjust the pilot hole depth according to the length of the super long type.)

■ 3. Initial cutting with the long type drill

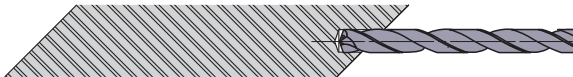

- ① Penetrate the pilot hole at a low revolution. (Cutting speed 20–30m/min, feed rate 0.2–0.3mm/rev)
- ② Stop the long type drill 1–3mm short of the pilot hole bottom.

■ 4. Drill the deep hole

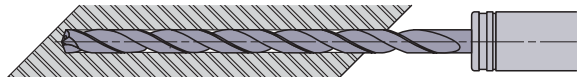

- ① Start cutting at the recommended speed and feed with a non-peck (continuous feed) cycle.

■ 5. Breaking through

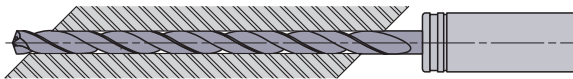

- ① When breaking through, the cutting edge can be damaged.
- ② A feed rate of 0.05–0.1mm/rev is recommended.

■ 6. Drill retraction

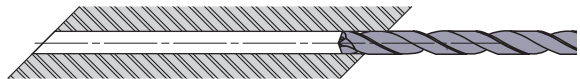

- ① Retract the drill to the pilot hole depth starting point at a feed rate of 3000mm/min.
- ② Finally clear the hole at a cutting speed of 20–30m/min and feed rate of 0.2–0.3mm/rev.

MAE / MAS

Foret carbure monobloc de haute précision
pour un usinage sécurisé des alliages
aluminium.



PRECISION
FOR SUCCESS

CHOOSE JAPAN'S NO. 1

mitsubishi
MITSUBISHI MATERIALS

www.mitsubishicarbide.com

Solid Carbide Drills for Aluminum Alloys

MAE/MAS

Features

1. Guide Pad

- 4 point support gives high hole accuracy.

2. Curved Cross-section

- Smooth curled chips are produced.
- Good chip control is due to efficient chip breaking.

3. Oil Hole

- Internal oil supply system makes it possible for deep hole drilling.

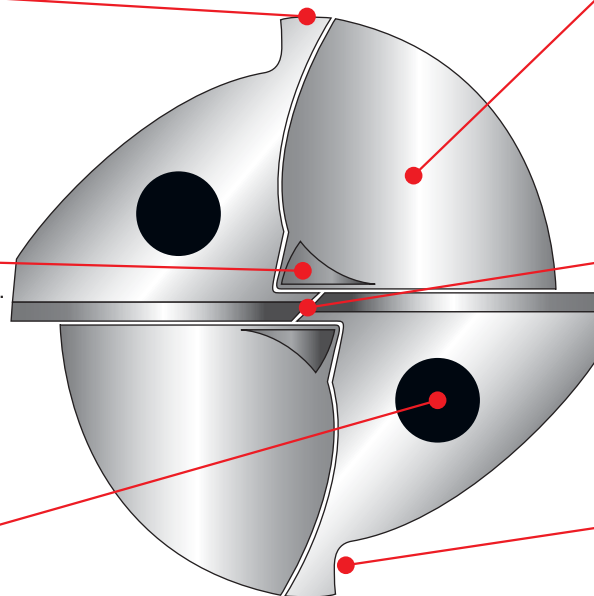

4. Flutes

- Employs 10° helix angle. Excellent chip discharge allows for high speed and high feed drilling.

5. Centre Point

- Initial drilling noise is minimal and deflection does not occur.

6. Secondary Flutes

- Cutting oil penetration is effective, so welding is negligible.
- Fine chips are evacuated easily.

Cutting performance

● Cutting Resistance

Workpiece : JIS AC4B-T Cutting depth : (L/D=3) through hole Cutting speed : 100m/min Cutting fluid : WSO (10%)

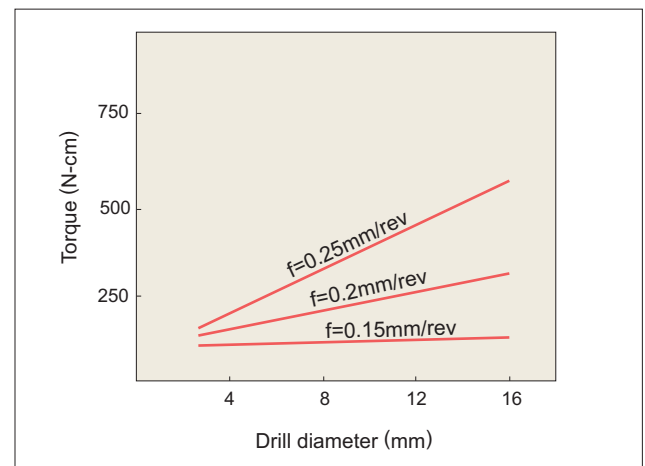
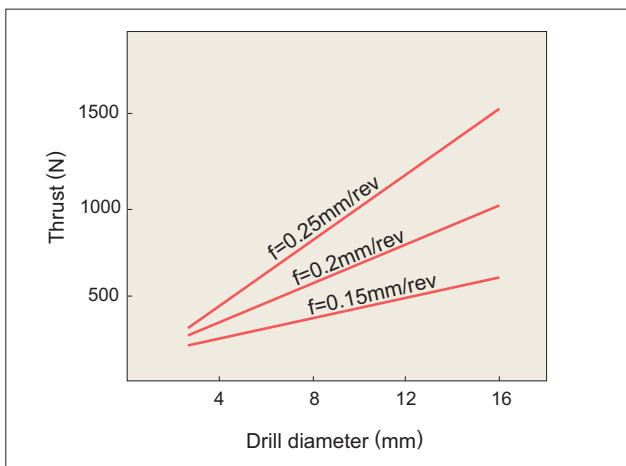

DRILLING (SOLID CARBIDE)

MAE, MAS

- Specialized for aluminium and cast iron drilling.
- High hole accuracy.
- Pre-hole drilling for roll taps.
- Helical through coolant hole enables high speed machining (MAS type).



MAE (External Coolant)

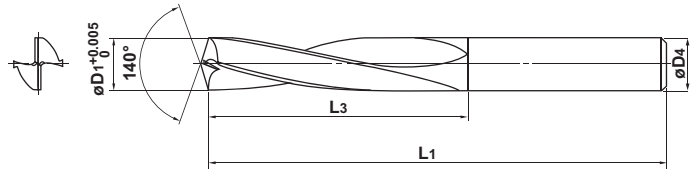

MAS (Internal Coolant)

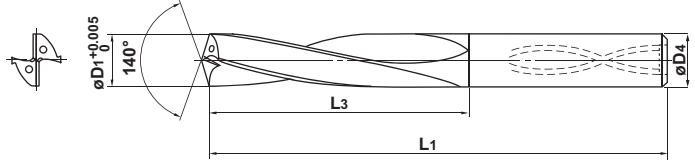

(Note) MAS type bigger than $\phi 5.0$ have a recess in the end face.

Drill Dia. D1 (mm)	Hole Depth (l/d)	Coolant (Int./Ext.)	Stock HTI10	Order Number	Dimensions (mm)		
					D4	L1	L3
3.0	3	Ext.	★	MAE0300MB	3	61	21
	3	Int.	□	MAS0300MB	3	61	21
	6	Int.	★	MAS0300LB	3	70	30
3.1	3	Ext.	★	MAE0310MB	4	64	24
	3	Int.	□	MAS0310MB	4	64	24
	6	Int.	★	MAS0310LB	4	74	34
3.2	3	Ext.	★	MAE0320MB	4	64	24
	3	Int.	□	MAS0320MB	4	64	24
	6	Int.	★	MAS0320LB	4	74	34
3.3	3	Ext.	★	MAE0330MB	4	64	24
	3	Int.	□	MAS0330MB	4	64	24
	6	Int.	★	MAS0330LB	4	74	34
3.4	3	Ext.	★	MAE0340MB	4	64	24
	3	Int.	□	MAS0340MB	4	64	24
	6	Int.	★	MAS0340LB	4	74	34
3.5	3	Ext.	★	MAE0350MB	4	64	24
	3	Int.	□	MAS0350MB	4	64	24
	6	Int.	★	MAS0350LB	4	74	34
3.6	3	Ext.	★	MAE0360MB	4	68	28
	3	Int.	□	MAS0360MB	4	68	28
	6	Int.	★	MAS0360LB	4	80	40
3.65	3	Ext.	★	* MAE0365MB	4	68	28
	3	Int.	□	* MAS0365MB	4	68	28
	6	Int.	★	* MAS0365LB	4	80	40
3.7	3	Ext.	★	MAE0370MB	4	68	28
	3	Int.	□	MAS0370MB	4	68	28
	6	Int.	★	MAS0370LB	4	80	40
3.8	3	Ext.	★	MAE0380MB	4	68	28
	3	Int.	□	MAS0380MB	4	68	28
	6	Int.	★	MAS0380LB	4	80	40
3.9	3	Ext.	★	MAE0390MB	4	68	28
	3	Int.	□	MAS0390MB	4	68	28
	6	Int.	★	MAS0390LB	4	80	40
4.0	3	Ext.	★	MAE0400MB	4	68	28
	3	Int.	□	MAS0400MB	4	68	28
	6	Int.	★	MAS0400LB	4	80	40
4.1	3	Ext.	★	MAE0410MB	5	71	31
	3	Int.	□	MAS0410MB	5	71	31
	6	Int.	★	MAS0410LB	5	84	44

Drill Dia. D1 (mm)	Hole Depth (l/d)	Coolant (Int./Ext.)	Stock HTI10	Order Number	Dimensions (mm)		
					D4	L1	L3
4.2	3	Ext.	★	MAE0420MB	5	71	31
	3	Int.	□	MAS0420MB	5	71	31
	6	Int.	★	MAS0420LB	5	84	44
4.3	3	Ext.	★	MAE0430MB	5	71	31
	3	Int.	□	MAS0430MB	5	71	31
	6	Int.	★	MAS0430LB	5	84	44
4.4	3	Ext.	★	MAE0440MB	5	71	31
	3	Int.	□	MAS0440MB	5	71	31
	6	Int.	★	MAS0440LB	5	84	44
4.5	3	Ext.	★	MAE0450MB	5	71	31
	3	Int.	□	MAS0450MB	5	71	31
	6	Int.	★	MAS0450LB	5	84	44
4.6	3	Ext.	★	* MAE0460MB	5	73	33
	3	Int.	□	* MAS0460MB	5	73	33
	6	Int.	★	* MAS0460LB	5	88	48
4.7	3	Ext.	★	MAE0470MB	5	73	33
	3	Int.	□	MAS0470MB	5	73	33
	6	Int.	★	MAS0470LB	5	88	48
4.8	3	Ext.	★	MAE0480MB	5	73	33
	3	Int.	□	MAS0480MB	5	73	33
	6	Int.	★	MAS0480LB	5	88	48
4.9	3	Ext.	★	MAE0490MB	5	73	33
	3	Int.	□	MAS0490MB	5	73	33
	6	Int.	★	MAS0490LB	5	88	48
5.0	3	Ext.	★	MAE0500MB	5	73	33
	3	Int.	★	MAS0500MB	5	73	33
	6	Int.	★	MAS0500LB	5	88	48
5.1	3	Ext.	★	MAE0510MB	6	76	36
	3	Int.	□	MAS0510MB	6	76	36
	6	Int.	★	MAS0510LB	6	92	52
5.2	3	Ext.	★	MAE0520MB	6	76	36
	3	Int.	□	MAS0520MB	6	76	36
	6	Int.	★	MAS0520LB	6	92	52
5.3	3	Ext.	★	MAE0530MB	6	76	36
	3	Int.	□	MAS0530MB	6	76	36
	6	Int.	★	MAS0530LB	6	92	52
5.4	3	Ext.	★	MAE0540MB	6	76	36
	3	Int.	□	MAS0540MB	6	76	36
	6	Int.	★	MAS0540LB	6	92	52

* : Standard hole size for rolled thread tap.

- : Stock Standard
- ★ : Stock Standard in Japan.
- : Non stock, produced to order only

DRILLING MAE, MAS DRILLS

Ø 3.00 ~ 5.40

Drill Dia. D1 (mm)	Hole Depth (l/d)	Coolant (Int./Ext.)	Stock HT110	Order Number	Dimensions (mm)		
					D4	L1	L3
5.5	3	Ext.	★	* MAE0550MB	6	76	36
	3	Int.	★	* MAS0550MB	6	76	36
	6	Int.	★	* MAS0550LB	6	92	52
5.6	3	Ext.	★	MAE0560MB	6	79	39
	3	Int.	□	MAS0560MB	6	79	39
	6	Int.	★	MAS0560LB	6	97	57
5.7	3	Ext.	★	MAE0570MB	6	79	39
	3	Int.	□	MAS0570MB	6	79	39
	6	Int.	★	MAS0570LB	6	97	57
5.8	3	Ext.	★	MAE0580MB	6	79	39
	3	Int.	□	MAS0580MB	6	79	39
	6	Int.	★	MAS0580LB	6	97	57
5.9	3	Ext.	★	MAE0590MB	6	79	39
	3	Int.	□	MAS0590MB	6	79	39
	6	Int.	★	MAS0590LB	6	97	57
6.0	3	Ext.	★	MAE0600MB	6	79	39
	3	Int.	★	MAS0600MB	6	79	39
	6	Int.	★	MAS0600LB	6	97	57
6.1	3	Ext.	★	MAE0610MB	7	84	42
	3	Int.	□	MAS0610MB	7	84	42
	6	Int.	★	MAS0610LB	7	104	62
6.2	3	Ext.	★	MAE0620MB	7	84	42
	3	Int.	□	MAS0620MB	7	84	42
	6	Int.	★	MAS0620LB	7	104	62
6.3	3	Ext.	★	MAE0630MB	7	84	42
	3	Int.	□	MAS0630MB	7	84	42
	6	Int.	★	MAS0630LB	7	104	62
6.4	3	Ext.	★	MAE0640MB	7	84	42
	3	Int.	□	MAS0640MB	7	84	42
	6	Int.	★	MAS0640LB	7	104	62
6.5	3	Ext.	★	MAE0650MB	7	84	42
	3	Int.	★	MAS0650MB	7	84	42
	6	Int.	★	MAS0650LB	7	104	62
6.6	3	Ext.	★	MAE0660MB	7	84	42
	3	Int.	□	MAS0660MB	7	84	42
	6	Int.	★	MAS0660LB	7	107	65
6.7	3	Ext.	★	MAE0670MB	7	84	42
	3	Int.	□	MAS0670MB	7	84	42
	6	Int.	★	MAS0670LB	7	107	65
6.8	3	Ext.	★	MAE0680MB	7	84	42
	3	Int.	★	MAS0680MB	7	84	42
	6	Int.	★	MAS0680LB	7	107	65
6.9	3	Ext.	★	MAE0690MB	7	84	42
	3	Int.	□	MAS0690MB	7	84	42
	6	Int.	★	MAS0690LB	7	107	65
7.0	3	Ext.	★	MAE0700MB	7	84	42
	3	Int.	★	MAS0700MB	7	84	42
	6	Int.	★	MAS0700LB	7	107	65

* : Standard hole size for rolled thread tap.

Drill Dia. D1 (mm)	Hole Depth (l/d)	Coolant (Int./Ext.)	Stock HT110	Order Number	Dimensions (mm)		
					D4	L1	L3
7.1	3	Ext.	★	MAE0710MB	8	90	48
	3	Int.	□	MAS0710MB	8	90	48
	6	Int.	★	MAS0710LB	8	110	68
7.2	3	Ext.	★	MAE0720MB	8	90	48
	3	Int.	□	MAS0720MB	8	90	48
	6	Int.	★	MAS0720LB	8	110	68
7.3	3	Ext.	★	MAE0730MB	8	90	48
	3	Int.	□	MAS0730MB	8	90	48
	6	Int.	★	MAS0730LB	8	110	68
7.35	3	Ext.	★	* MAE0735MB	8	90	48
	3	Int.	★	* MAS0735MB	8	90	48
	6	Int.	★	* MAS0735LB	8	110	68
7.4	3	Ext.	★	MAE0740MB	8	90	48
	3	Int.	□	MAS0740MB	8	90	48
	6	Int.	★	MAS0740LB	8	110	68
7.5	3	Ext.	★	MAE0750MB	8	90	48
	3	Int.	□	MAS0750MB	8	90	48
	6	Int.	★	MAS0750LB	8	110	68
7.6	3	Ext.	★	MAE0760MB	8	90	48
	3	Int.	□	MAS0760MB	8	90	48
	6	Int.	★	MAS0760LB	8	114	72
7.7	3	Ext.	★	MAE0770MB	8	90	48
	3	Int.	□	MAS0770MB	8	90	48
	6	Int.	★	MAS0770LB	8	114	72
7.8	3	Ext.	★	MAE0780MB	8	90	48
	3	Int.	□	MAS0780MB	8	90	48
	6	Int.	★	MAS0780LB	8	114	72
7.9	3	Ext.	★	MAE0790MB	8	90	48
	3	Int.	□	MAS0790MB	8	90	48
	6	Int.	★	MAS0790LB	8	114	72
8.0	3	Ext.	★	MAE0800MB	8	90	48
	3	Int.	★	MAS0800MB	8	90	48
	6	Int.	★	MAS0800LB	8	114	72
8.1	3	Ext.	★	MAE0810MB	9	94	50
	3	Int.	□	MAS0810MB	9	94	50
	6	Int.	★	MAS0810LB	9	119	75
8.2	3	Ext.	★	MAE0820MB	9	94	50
	3	Int.	□	MAS0820MB	9	94	50
	6	Int.	★	MAS0820LB	9	119	75
8.3	3	Ext.	★	MAE0830MB	9	94	50
	3	Int.	□	MAS0830MB	9	94	50
	6	Int.	★	MAS0830LB	9	119	75
8.4	3	Ext.	★	MAE0840MB	9	94	50
	3	Int.	□	MAS0840MB	9	94	50
	6	Int.	★	MAS0840LB	9	119	75
8.5	3	Ext.	★	MAE0850MB	9	94	50
	3	Int.	★	MAS0850MB	9	94	50
	6	Int.	★	MAS0850LB	9	119	75

MAE, MAS DRILLS



CUTTING CONDITIONS

D125

D121

DRILLING (SOLID CARBIDE)

MAE, MAS

- Specialized for aluminium and cast iron drilling.
- High hole accuracy.
- Pre-hole drilling for roll taps.
- Helical through coolant hole enables high speed machining (MAS type).



MAE (External Coolant)

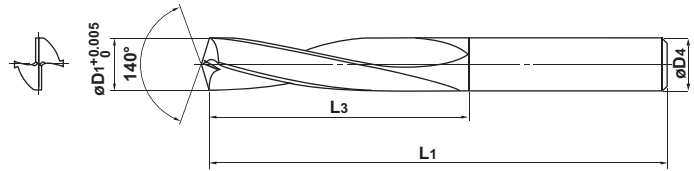

MAS (Internal Coolant)

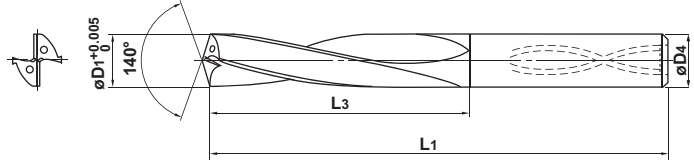

(Note) MAS type bigger than $\phi 5.0$ have a recess in the end face.

Drill Dia. D1 (mm)	Hole Depth (l/d)	Coolant (Int./Ext.)	Stock HTI10	Order Number	Dimensions (mm)		
					D4	L1	L3
8.6	3	Ext.	★	MAE0860MB	9	94	50
	3	Int.	□	MAS0860MB	9	94	50
	6	Int.	★	MAS0860LB	9	121	77
8.7	3	Ext.	★	MAE0870MB	9	94	50
	3	Int.	□	MAS0870MB	9	94	50
	6	Int.	★	MAS0870LB	9	121	77
8.8	3	Ext.	★	MAE0880MB	9	94	50
	3	Int.	□	MAS0880MB	9	94	50
	6	Int.	★	MAS0880LB	9	121	77
8.9	3	Ext.	★	MAE0890MB	9	94	50
	3	Int.	□	MAS0890MB	9	94	50
	6	Int.	★	MAS0890LB	9	121	77
9.0	3	Ext.	★	MAE0900MB	9	94	50
	3	Int.	★	MAS0900MB	9	94	50
	6	Int.	★	MAS0900LB	9	121	77
9.1	3	Ext.	★	MAE0910MB	10	97	53
	3	Int.	□	MAS0910MB	10	97	53
	6	Int.	★	MAS0910LB	10	125	81
9.2	3	Ext.	★	MAE0920MB	10	97	53
	3	Int.	□	MAS0920MB	10	97	53
	6	Int.	★	MAS0920LB	10	125	81
9.21	3	Ext.	★	* MAE0921MB	10	97	53
	3	Int.	★	* MAS0921MB	10	97	53
	6	Int.	★	* MAS0921LB	10	125	81
9.3	3	Ext.	★	MAE0930MB	10	97	53
	3	Int.	□	MAS0930MB	10	97	53
	6	Int.	★	MAS0930LB	10	125	81
9.4	3	Ext.	★	MAE0940MB	10	97	53
	3	Int.	□	MAS0940MB	10	97	53
	6	Int.	★	MAS0940LB	10	125	81
9.5	3	Ext.	★	MAE0950MB	10	97	53
	3	Int.	★	MAS0950MB	10	97	53
	6	Int.	★	MAS0950LB	10	125	81
9.6	3	Ext.	★	MAE0960MB	10	97	53
	3	Int.	□	MAS0960MB	10	97	53
	6	Int.	★	MAS0960LB	10	125	81
9.7	3	Ext.	★	MAE0970MB	10	97	53
	3	Int.	□	MAS0970MB	10	97	53
	6	Int.	★	MAS0970LB	10	125	81

Drill Dia. D1 (mm)	Hole Depth (l/d)	Coolant (Int./Ext.)	Stock HTI10	Order Number	Dimensions (mm)		
					D4	L1	L3
9.8	3	Ext.	★	MAE0980MB	10	97	53
	3	Int.	□	MAS0980MB	10	97	53
	6	Int.	★	MAS0980LB	10	125	81
9.9	3	Ext.	★	MAE0990MB	10	97	53
	3	Int.	□	MAS0990MB	10	97	53
	6	Int.	★	MAS0990LB	10	125	81
10.0	3	Ext.	★	MAE1000MB	10	97	53
	3	Int.	★	MAS1000MB	10	97	53
	6	Int.	★	MAS1000LB	10	125	81
10.1	3	Ext.	□	MAE1010MB	11	101	55
	3	Int.	□	MAS1010MB	11	101	55
	6	Int.	□	MAS1010LB	11	135	89
10.2	3	Ext.	□	MAE1020MB	11	101	55
	3	Int.	□	MAS1020MB	11	101	55
	6	Int.	□	MAS1020LB	11	135	89
10.3	3	Ext.	★	MAE1030MB	11	101	55
	3	Int.	★	MAS1030MB	11	101	55
	6	Int.	★	MAS1030LB	11	135	89
10.4	3	Ext.	□	MAE1040MB	11	101	55
	3	Int.	□	MAS1040MB	11	101	55
	6	Int.	□	MAS1040LB	11	135	89
10.5	3	Ext.	★	MAE1050MB	11	101	55
	3	Int.	★	MAS1050MB	11	101	55
	6	Int.	★	MAS1050LB	11	135	89
10.6	3	Ext.	□	MAE1060MB	11	101	55
	3	Int.	□	MAS1060MB	11	101	55
	6	Int.	□	MAS1060LB	11	135	89
10.7	3	Ext.	□	MAE1070MB	11	101	55
	3	Int.	□	MAS1070MB	11	101	55
	6	Int.	□	MAS1070LB	11	135	89
10.8	3	Ext.	□	MAE1080MB	11	101	55
	3	Int.	□	MAS1080MB	11	101	55
	6	Int.	□	MAS1080LB	11	135	89
10.9	3	Ext.	□	MAE1090MB	11	101	55
	3	Int.	□	MAS1090MB	11	101	55
	6	Int.	□	MAS1090LB	11	135	89
11.0	3	Ext.	★	MAE1100MB	11	101	55
	3	Int.	★	MAS1100MB	11	101	55
	6	Int.	★	MAS1100LB	11	135	89

* : Standard hole size for rolled thread tap.

DRILLING MAE, MAS DRILLS



Ø 8.6 ~ 11.0

- : Stock Standard
- ★ : Stock Standard in Japan.
- : Non stock, produced to order only

Drill Dia. D1 (mm)	Hole Depth (l/d)	Coolant (Int./Ext.)	Stock HT110	Order Number	Dimensions (mm)		
					D4	L1	L3
11.08	3	Ext.	★	* MAE1108MB	12	106	60
	3	Int.	★	* MAS1108MB	12	106	60
	6	Int.	★	* MAS1108LB	12	140	94
11.1	3	Ext.	□	MAE1110MB	12	106	60
	3	Int.	□	MAS1110MB	12	106	60
	6	Int.	□	MAS1110LB	12	140	94
11.2	3	Ext.	□	MAE1120MB	12	106	60
	3	Int.	□	MAS1120MB	12	106	60
	6	Int.	□	MAS1120LB	12	140	94
11.3	3	Ext.	□	MAE1130MB	12	106	60
	3	Int.	□	MAS1130MB	12	106	60
	6	Int.	□	MAS1130LB	12	140	94
11.4	3	Ext.	□	MAE1140MB	12	106	60
	3	Int.	□	MAS1140MB	12	106	60
	6	Int.	□	MAS1140LB	12	140	94
11.5	3	Ext.	□	MAE1150MB	12	106	60
	3	Int.	□	MAS1150MB	12	106	60
	6	Int.	□	MAS1150LB	12	140	94
11.6	3	Ext.	□	MAE1160MB	12	106	60
	3	Int.	□	MAS1160MB	12	106	60
	6	Int.	□	MAS1160LB	12	140	94
11.7	3	Ext.	□	MAE1170MB	12	106	60
	3	Int.	□	MAS1170MB	12	106	60
	6	Int.	□	MAS1170LB	12	140	94
11.8	3	Ext.	□	MAE1180MB	12	106	60
	3	Int.	□	MAS1180MB	12	106	60
	6	Int.	□	MAS1180LB	12	140	94
11.9	3	Ext.	□	MAE1190MB	12	106	60
	3	Int.	□	MAS1190MB	12	106	60
	6	Int.	□	MAS1190LB	12	140	94
12.0	3	Ext.	★	MAE1200MB	12	106	60
	3	Int.	★	MAS1200MB	12	106	60
	6	Int.	★	MAS1200LB	12	140	94
12.1	3	Ext.	□	MAE1210MB	13	115	65
	3	Int.	□	MAS1210MB	13	115	65
	6	Int.	□	MAS1210LB	13	150	100
12.2	3	Ext.	□	MAE1220MB	13	115	65
	3	Int.	□	MAS1220MB	13	115	65
	6	Int.	□	MAS1220LB	13	150	100
12.3	3	Ext.	□	MAE1230MB	13	115	65
	3	Int.	□	MAS1230MB	13	115	65
	6	Int.	□	MAS1230LB	13	150	100
12.4	3	Ext.	□	MAE1240MB	13	115	65
	3	Int.	□	MAS1240MB	13	115	65
	6	Int.	□	MAS1240LB	13	150	100
12.5	3	Ext.	★	MAE1250MB	13	115	65
	3	Int.	★	MAS1250MB	13	115	65
	6	Int.	★	MAS1250LB	13	150	100

* : Standard hole size for rolled thread tap.

Drill Dia. D1 (mm)	Hole Depth (l/d)	Coolant (Int./Ext.)	Stock HT110	Order Number	Dimensions (mm)		
					D4	L1	L3
12.6	3	Ext.	□	MAE1260MB	13	115	65
	3	Int.	□	MAS1260MB	13	115	65
	6	Int.	□	MAS1260LB	13	150	100
12.7	3	Ext.	□	MAE1270MB	13	115	65
	3	Int.	□	MAS1270MB	13	115	65
	6	Int.	□	MAS1270LB	13	150	100
12.8	3	Ext.	□	MAE1280MB	13	115	65
	3	Int.	□	MAS1280MB	13	115	65
	6	Int.	□	MAS1280LB	13	150	100
12.9	3	Ext.	□	MAE1290MB	13	115	65
	3	Int.	□	MAS1290MB	13	115	65
	6	Int.	□	MAS1290LB	13	150	100
12.96	3	Ext.	★	* MAE1296MB	13	115	65
	3	Int.	★	* MAS1296MB	13	115	65
	6	Int.	★	* MAS1296LB	13	150	100
13.0	3	Ext.	★	MAE1300MB	13	115	65
	3	Int.	★	MAS1300MB	13	115	65
	6	Int.	★	MAS1300LB	13	150	100
13.1	3	Ext.	□	MAE1310MB	14	120	70
	3	Int.	□	MAS1310MB	14	120	70
	6	Int.	□	MAS1310LB	14	160	110
13.2	3	Ext.	□	MAE1320MB	14	120	70
	3	Int.	□	MAS1320MB	14	120	70
	6	Int.	□	MAS1320LB	14	160	110
13.3	3	Ext.	□	MAE1330MB	14	120	70
	3	Int.	□	MAS1330MB	14	120	70
	6	Int.	□	MAS1330LB	14	160	110
13.4	3	Ext.	□	MAE1340MB	14	120	70
	3	Int.	□	MAS1340MB	14	120	70
	6	Int.	□	MAS1340LB	14	160	110
13.5	3	Ext.	★	MAE1350MB	14	120	70
	3	Int.	★	MAS1350MB	14	120	70
	6	Int.	★	MAS1350LB	14	160	110
13.6	3	Ext.	□	MAE1360MB	14	120	70
	3	Int.	□	MAS1360MB	14	120	70
	6	Int.	□	MAS1360LB	14	160	110
13.7	3	Ext.	□	MAE1370MB	14	120	70
	3	Int.	□	MAS1370MB	14	120	70
	6	Int.	□	MAS1370LB	14	160	110
13.8	3	Ext.	□	MAE1380MB	14	120	70
	3	Int.	□	MAS1380MB	14	120	70
	6	Int.	□	MAS1380LB	14	160	110
13.9	3	Ext.	□	MAE1390MB	14	120	70
	3	Int.	□	MAS1390MB	14	120	70
	6	Int.	□	MAS1390LB	14	160	110
14.0	3	Ext.	★	MAE1400MB	14	120	70
	3	Int.	★	MAS1400MB	14	120	70
	6	Int.	★	MAS1400LB	14	160	110

MAE, MAS DRILLS



Ø11.08~14.0

CUTTING CONDITIONS

D125

D123

DRILLING (SOLID CARBIDE)

MAE, MAS

- Specialized for aluminium and cast iron drilling.
- High hole accuracy.
- Pre-hole drilling for roll taps.
- Helical through coolant hole enables high speed machining (MAS type).



MAE (External Coolant)

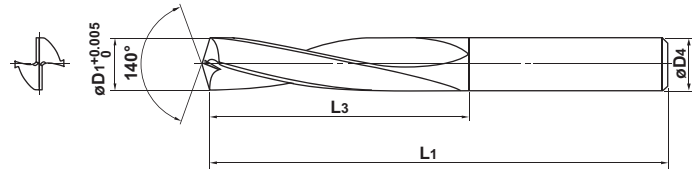

MAS (Internal Coolant)

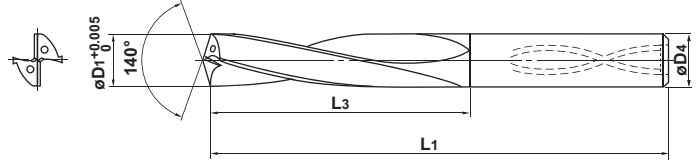

(Note) MAS type bigger than $\phi 5.0$ have a recess in the end face.

Drill Dia. D1 (mm)	Hole Depth (l/d)	Coolant (Int./Ext.)	Stock HTI10	Order Number	Dimensions (mm)		
					D4	L1	L3
14.1	3	Ext.	<input type="checkbox"/>	MAE1410MB	15	130	72
	3	Int.	<input type="checkbox"/>	MAS1410MB	15	130	72
	6	Int.	<input type="checkbox"/>	MAS1410LB	15	173	115
14.2	3	Ext.	<input type="checkbox"/>	MAE1420MB	15	130	72
	3	Int.	<input type="checkbox"/>	MAS1420MB	15	130	72
	6	Int.	<input type="checkbox"/>	MAS1420LB	15	173	115
14.3	3	Ext.	<input type="checkbox"/>	MAE1430MB	15	130	72
	3	Int.	<input type="checkbox"/>	MAS1430MB	15	130	72
	6	Int.	<input type="checkbox"/>	MAS1430LB	15	173	115
14.4	3	Ext.	<input type="checkbox"/>	MAE1440MB	15	130	72
	3	Int.	<input type="checkbox"/>	MAS1440MB	15	130	72
	6	Int.	<input type="checkbox"/>	MAS1440LB	15	173	115
14.5	3	Ext.	<input type="checkbox"/>	MAE1450MB	15	130	72
	3	Int.	<input type="checkbox"/>	MAS1450MB	15	130	72
	6	Int.	<input type="checkbox"/>	MAS1450LB	15	173	115
14.6	3	Ext.	<input type="checkbox"/>	MAE1460MB	15	130	72
	3	Int.	<input type="checkbox"/>	MAS1460MB	15	130	72
	6	Int.	<input type="checkbox"/>	MAS1460LB	15	173	115
14.7	3	Ext.	<input type="checkbox"/>	MAE1470MB	15	130	72
	3	Int.	<input type="checkbox"/>	MAS1470MB	15	130	72
	6	Int.	<input type="checkbox"/>	MAS1470LB	15	173	115
14.8	3	Ext.	<input type="checkbox"/>	MAE1480MB	15	130	72
	3	Int.	<input type="checkbox"/>	MAS1480MB	15	130	72
	6	Int.	<input type="checkbox"/>	MAS1480LB	15	173	115
14.9	3	Ext.	<input type="checkbox"/>	MAE1490MB	15	130	72
	3	Int.	<input type="checkbox"/>	MAS1490MB	15	130	72
	6	Int.	<input type="checkbox"/>	MAS1490LB	15	173	115
14.96	3	Ext.	★	* MAE1496MB	15	130	72
	3	Int.	★	* MAS1496MB	15	130	72
	6	Int.	★	* MAS1496LB	15	173	115
15.0	3	Ext.	★	MAE1500MB	15	130	72
	3	Int.	★	MAS1500MB	15	130	72
	6	Int.	★	MAS1500LB	15	173	115
15.1	3	Ext.	<input type="checkbox"/>	MAE1510MB	16	134	76
	3	Int.	<input type="checkbox"/>	MAS1510MB	16	134	76
	6	Int.	<input type="checkbox"/>	MAS1510LB	16	178	120

Drill Dia. D1 (mm)	Hole Depth (l/d)	Coolant (Int./Ext.)	Stock HTI10	Order Number	Dimensions (mm)		
					D4	L1	L3
15.2	3	Ext.	<input type="checkbox"/>	MAE1520MB	16	134	76
	3	Int.	<input type="checkbox"/>	MAS1520MB	16	134	76
	6	Int.	<input type="checkbox"/>	MAS1520LB	16	178	120
15.3	3	Ext.	<input type="checkbox"/>	MAE1530MB	16	134	76
	3	Int.	<input type="checkbox"/>	MAS1530MB	16	134	76
	6	Int.	<input type="checkbox"/>	MAS1530LB	16	178	120
15.4	3	Ext.	<input type="checkbox"/>	MAE1540MB	16	134	76
	3	Int.	<input type="checkbox"/>	MAS1540MB	16	134	76
	6	Int.	<input type="checkbox"/>	MAS1540LB	16	178	120
15.5	3	Ext.	<input type="checkbox"/>	MAE1550MB	16	134	76
	3	Int.	<input type="checkbox"/>	MAS1550MB	16	134	76
	6	Int.	<input type="checkbox"/>	MAS1550LB	16	178	120
15.6	3	Ext.	<input type="checkbox"/>	MAE1560MB	16	134	76
	3	Int.	<input type="checkbox"/>	MAS1560MB	16	134	76
	6	Int.	<input type="checkbox"/>	MAS1560LB	16	178	120
15.7	3	Ext.	<input type="checkbox"/>	MAE1570MB	16	134	76
	3	Int.	<input type="checkbox"/>	MAS1570MB	16	134	76
	6	Int.	<input type="checkbox"/>	MAS1570LB	16	178	120
15.8	3	Ext.	<input type="checkbox"/>	MAE1580MB	16	134	76
	3	Int.	<input type="checkbox"/>	MAS1580MB	16	134	76
	6	Int.	<input type="checkbox"/>	MAS1580LB	16	178	120
15.9	3	Ext.	<input type="checkbox"/>	MAE1590MB	16	134	76
	3	Int.	<input type="checkbox"/>	MAS1590MB	16	134	76
	6	Int.	<input type="checkbox"/>	MAS1590LB	16	178	120
16.0	3	Ext.	★	MAE1600MB	16	134	76
	3	Int.	★	MAS1600MB	16	134	76
	6	Int.	★	MAS1600LB	16	178	120

★ : Standard hole size for rolled thread tap.

DRILLING | MAE, MAS DRILLS



Ø 14.1
16.0

- : Stock Standard
- ★ : Stock Standard in Japan.
- : Non stock, produced to order only

RECOMMENDED CUTTING CONDITIONS

● MAE (External Coolant)

Work Material	Condition	Tensile Strength N/mm ²	Hardn. HB	Drill Dia. ϕ 3.0– ϕ 5.9		Drill Dia. ϕ 6.0– ϕ 9.9		Drill Dia. ϕ 10.0– ϕ 16.0	
				Cutting Speed (m/min)	Feed (mm/rev)	Cutting Speed (m/min)	Feed (mm/rev)	Cutting Speed (m/min)	Feed (mm/rev)
K Laminated Graphite Cast Iron	ferritic	100–400	<180	40	0.15	60	0.20	80	0.30
	pearlitic		220	40	0.15	60	0.20	80	0.30
Spheroidal Cast Iron Ductile Cast Iron	ferritic	400–800	<180	30	0.10	40	0.12	60	0.20
	pearlitic		250	30	0.10	40	0.12	60	0.20
Tempered and Black Cast Iron	ferritic	350–700	<180	30	0.10	40	0.12	60	0.20
	pearlitic		220	30	0.10	40	0.12	60	0.20
N Al,Mg.Alloy Aluminium Alloy	<12%	<400	80	90	0.15	100	0.15	120	0.25
	>12%	<400	130	60	0.15	70	0.20	80	0.25
Copper Alloy	Ms, Rg		90	100	0.15	120	0.20	150	0.30
	Ms, Rg		110	90	0.15	110	0.20	140	0.25
	Bz, Cu		100	120	0.10	130	0.10	150	0.10
Plastics	Thermpol.			300	0.08	300	0.12	300	0.15
	Duropl.	20–40		300	0.05	300	0.05	300	0.05
	Visc. Plastics			150	0.15	150	0.25	150	0.35

● MAS (Internal Coolant)

Work Material	Condition	Tensile Strength N/mm ²	Hardn. HB	Drill Dia. ϕ 3.0– ϕ 5.9		Drill Dia. ϕ 6.0– ϕ 9.9		Drill Dia. ϕ 10.0– ϕ 16.0	
				Cutting Speed (m/min)	Feed (mm/rev)	Cutting Speed (m/min)	Feed (mm/rev)	Cutting Speed (m/min)	Feed (mm/rev)
K Laminated Graphite Cast Iron	ferritic	100–400	<180	60	0.20	80	0.25	100	0.30
	pearlitic		220	60	0.20	80	0.25	100	0.30
Spheroidal Cast Iron Ductile Cast Iron	ferritic	400–800	<180	50	0.15	60	0.25	80	0.25
	pearlitic		250	50	0.15	60	0.25	80	0.25
Tempered and Black Cast Iron	ferritic	350–700	<180	50	0.15	60	0.25	80	0.25
	pearlitic		220	50	0.15	60	0.25	80	0.25
N Al,Mg.Alloy Aluminium Alloy	<12%	<400	80	120	0.20	150	0.30	160	0.40
	>12%	<400	130	120	0.20	150	0.30	160	0.40
Copper Alloy	Ms, Rg		90	100	0.15	120	0.20	150	0.30
	Ms, Rg		110	90	0.15	110	0.20	140	0.25
	Bz, Cu		100	120	0.10	130	0.10	150	0.10
Plastics	Thermpol.			300	0.08	300	0.12	300	0.15
	Duropl.	20–40		300	0.05	300	0.05	300	0.05
	Visc. Plastics			150	0.15	150	0.25	150	0.35

MAE, MAS DRILLS



■ HOLE AND DRILL DIAMETERS FOR THREAD TAPPING

Thread Size	Thread Tapping			Rolled Thread Tapping		
	Drill Diameter (ϕ D1)	Hole Diameter Tolerance		Drill Diameter (ϕ D1)	Hole Diameter Tolerance	
		max	min		max	min
M4x0.7	3.3	3.242	3.422	3.65	3.65	3.70
M5x0.8	4.2	4.134	4.334	4.60	4.59	4.66
M6x1.0	5.0	4.917	5.153	5.50	5.48	5.57
M8x1.25	6.8	6.647	6.912	7.35	7.34	7.41
M10x1.5	8.5	8.376	8.676	9.21	9.18	9.28
M12x1.75	10.3	10.106	10.441	11.08	11.05	11.15
M14x2	12.0	11.835	12.210	12.96	12.92	13.04
M16x2	14.0	13.835	14.210	14.96	14.92	15.04



MHS

Solid Carbide Drill for Die & Mould Machining.
Innovative drilling solutions for hardened steel.
Possible to machine high precision deep holes
for resin and die casting moulds.



PRECISION
FOR SUCCESS

CHOOSE JAPAN'S NO. 1

MITSUBISHI
MITSUBISHI MATERIALS

www.mitsubishicarbide.com

Solid Carbide Drill for Die & Mould Machining

MHS

Features

Stable machining can be obtained due to the unique cutting edge geometry & double margin flute

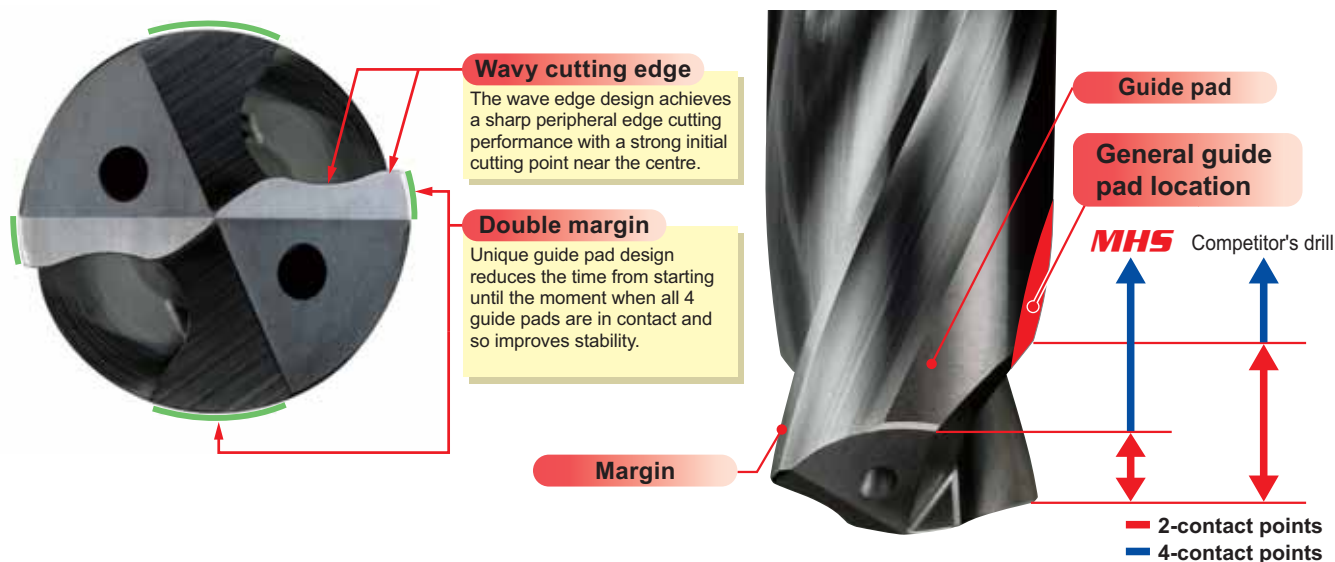

Strong geometry for stable machining of moulds



Web thickness
In comparison with conventional drills a larger web thickness is used to increase overall rigidity.

Helix angle
In comparison with conventional drills, a lower helix angle is used to maintain cutting edge strength.

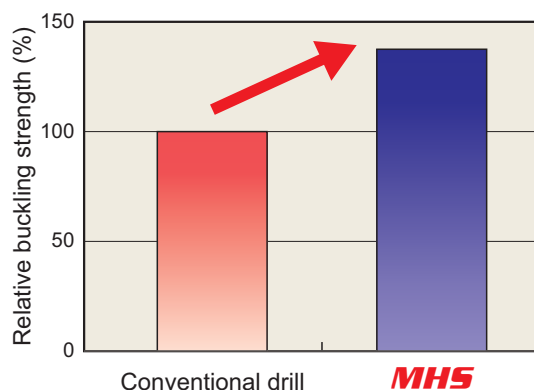

37% increase in rigidity.
(Compared to other Mitsubishi Materials drills)

Tough carbide grade

● Long tool life MIRACLE® coated VP15TF

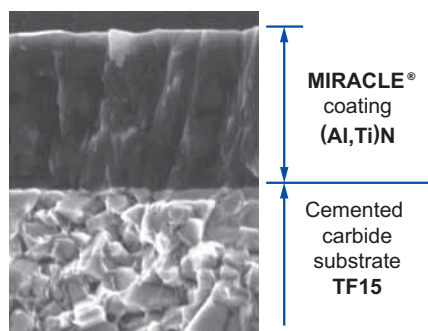

VP15T



Features of VP15TF

Miracle coated VP15TF is suitable for the machining of 35–55HRC mould materials.

Cutting Performance

- Unique geometry specially designed for die and mould machining.
- High precision (oversize) (48–50HRC)

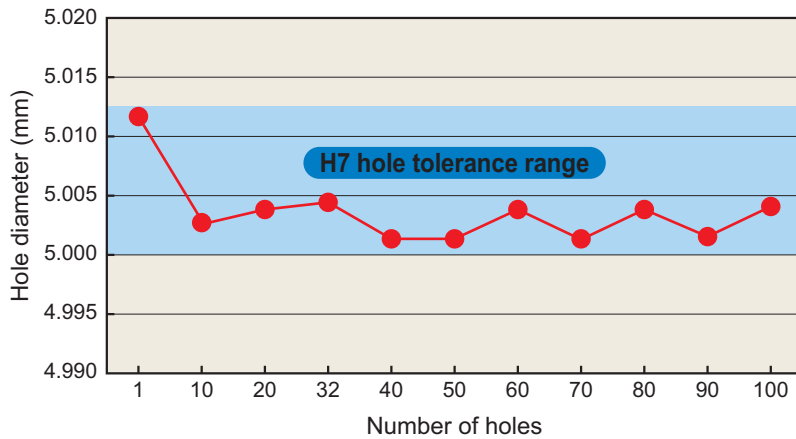

<Cutting conditions>
 Workpiece : Alloy tool steel
 Hardness : 48–50HRC
 Drill : MHS0500L090B (ø5mm)
 Hole depth : 70mm
 Cutting speed : 20m/min
 Feed : 0.15mm/rev (continuous)
 Feed Rate : 191mm/min
 Coolant : W.S.O.
 Emission pressure : 2MPa (Internal coolant)
 Machine : Machining centre

<Cutting conditions for pilot drilling>
 Drill : MHS0500L020B (ø5mm)
 Hole depth : 5mm
 Cutting speed : 20m/min
 Feed : 0.15mm/rev

High precision (surface roughness) (48–50HRC)

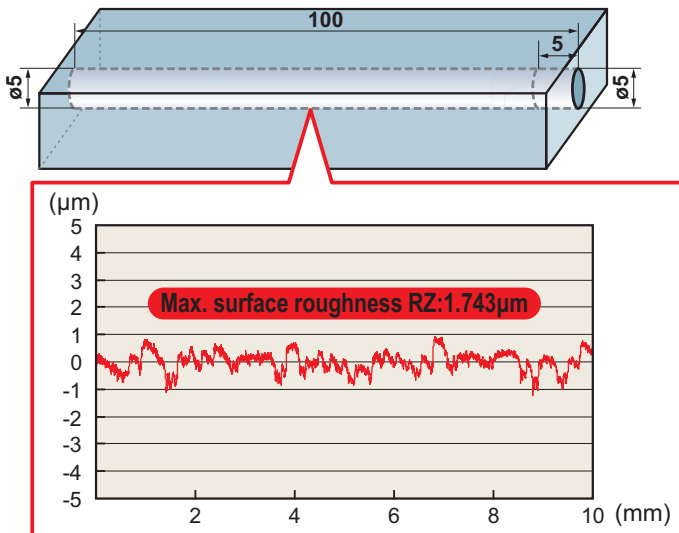

<Cutting conditions>
 Workpiece : Mould steel
 Hardness : 48–50HRC
 Drill : MHS0500L120B (ø5mm)
 Hole depth : 100mm (Through hole)
 Cutting speed : 20m/min
 Feed : 0.10mm/rev (continuous)
 Feed Rate : 127mm/min
 Coolant : W.S.O.
 Emission pressure : 2MPa (Internal coolant)
 Machine : Machining centre

<Cutting conditions for pilot drilling>
 Drill : MHS0500L020B (ø5mm)
 Hole depth : 5mm
 Cutting speed : 20m/min
 Feed : 0.10mm/rev

High efficiency drilling (continuous feed) (40HRC)

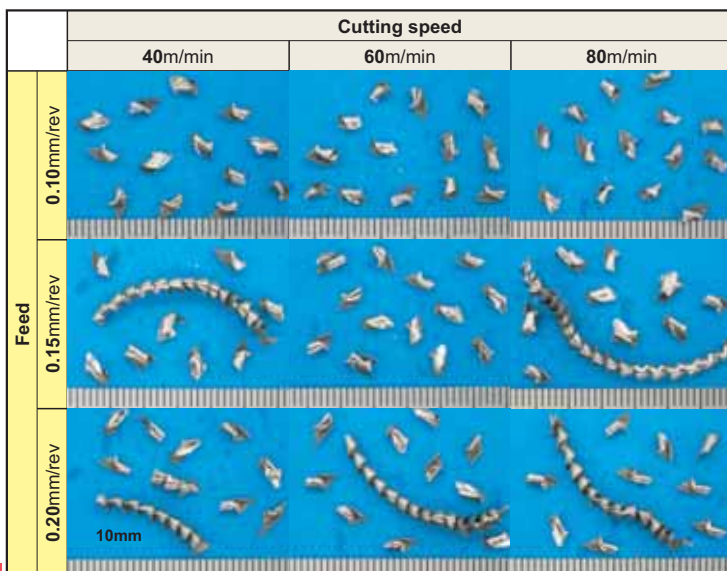

<Cutting conditions>
 Workpiece : Plastic mould steel
 Hardness : 40HRC
 Drill : MHS0600L150B (ø6mm)
 Hole depth : 115mm
 Cutting speed : 60m/min
 Feed : 0.15mm/rev (continuous)
 Feed Rate : 477mm/min
 Coolant : W.S.O.
 Emission pressure : 2MPa (Internal coolant)
 Machine : Machining centre

<Cutting conditions for pilot drilling>
 Drill : MHS0600L030B (ø6mm)
 Hole depth : 6mm
 Cutting speed : 60m/min
 Feed : 0.15mm/rev

DRILLING (SOLID CARBIDE)

MHS

- Possible to machine high precision deep holes for resin and die casting moulds!
- Strong geometry for stable machining in hardened materials.



D1	3.0 ≤ D1 ≤ 6.0	6.0 < D1 ≤ 10.0	10.0 < D1 ≤ 12.0
Tolerance (mm)	+0.010 -0.002	+0.010 -0.005	+0.010 -0.008

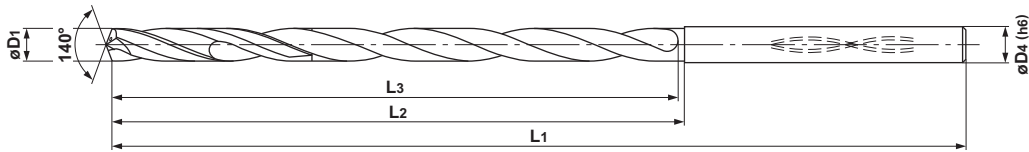

Note 1) MHS drills are suitable for use with shrink fit holders.
 Note 2) Use the shortest type in the respective diameter as a pilot drill.

Drill Dia. D1 (mm)	Hole Depth (l/d)	Coolant	Stock VP15TF	Order Number	Dimensions (mm)			
					L3	L2	L1	D4
3.0	4	Int.	★	MHS0300L020B	19.0	20	70	4.0
	10	Int.	★	0300L040B	39.0	40	90	4.0
	17	Int.	★	0300L060B	59.0	60	110	4.0
	27	Int.	★	0300L090B	89.0	90	140	4.0
3.1	4	Int.	□	0310L020B	19.5	20	70	4.0
	10	Int.	□	0310L040B	39.5	40	90	4.0
	17	Int.	□	0310L060B	59.5	60	110	4.0
	26	Int.	□	0310L090B	89.5	90	140	4.0
3.2	4	Int.	□	0320L020B	19.5	20	70	4.0
	10	Int.	□	0320L040B	39.5	40	90	4.0
	16	Int.	□	0320L060B	59.5	60	110	4.0
	25	Int.	□	0320L090B	89.5	90	140	4.0
3.3	3	Int.	□	0330L020B	19.5	20	70	4.0
	9	Int.	□	0330L040B	39.5	40	90	4.0
	16	Int.	□	0330L060B	59.5	60	110	4.0
	25	Int.	□	0330L090B	89.5	90	140	4.0
3.4	3	Int.	□	0340L020B	19.5	20	70	4.0
	9	Int.	□	0340L040B	39.5	40	90	4.0
	15	Int.	□	0340L060B	59.5	60	110	4.0
	24	Int.	□	0340L090B	89.5	90	140	4.0
3.5	3	Int.	★	0350L020B	19.5	20	70	4.0
	9	Int.	★	0350L040B	39.5	40	90	4.0
	14	Int.	★	0350L060B	59.5	60	110	4.0
	23	Int.	★	0350L090B	89.5	90	140	4.0
3.6	3	Int.	□	0360L020B	20.0	20	70	4.0
	9	Int.	□	0360L040B	40.0	40	90	4.0
	14	Int.	□	0360L060B	60.0	60	110	4.0
	22	Int.	□	0360L090B	90.0	90	140	4.0
3.7	3	Int.	□	0370L020B	20.0	20	70	4.0
	8	Int.	□	0370L040B	40.0	40	90	4.0
	14	Int.	□	0370L060B	60.0	60	110	4.0
	22	Int.	□	0370L090B	90.0	90	140	4.0
3.8	3	Int.	□	0380L020B	20.0	20	70	4.0
	8	Int.	□	0380L040B	40.0	40	90	4.0
	13	Int.	□	0380L060B	60.0	60	110	4.0
	21	Int.	□	0380L090B	90.0	90	140	4.0
3.9	3	Int.	□	0390L020B	20.0	20	70	4.0
	8	Int.	□	0390L040B	40.0	40	90	4.0
	13	Int.	□	0390L060B	60.0	60	110	4.0
	21	Int.	□	0390L090B	90.0	90	140	4.0
4.0	2	Int.	★	0400L020B	20.0	20	70	4.0
	7	Int.	★	0400L040B	40.0	40	90	4.0
	12	Int.	★	0400L060B	60.0	60	110	4.0
	20	Int.	★	0400L090B	90.0	90	140	4.0

Drill Dia. D1 (mm)	Hole Depth (l/d)	Coolant	Stock VP15TF	Order Number	Dimensions (mm)			
					L3	L2	L1	D4
4.1	2	Int.	□	MHS0410L020B	18.5	20	70	6.0
	7	Int.	□	0410L040B	38.5	40	90	6.0
	12	Int.	□	0410L060B	58.5	60	110	6.0
	19	Int.	□	0410L090B	88.5	90	140	6.0
	26	Int.	□	0410L120B	118.5	120	170	6.0
4.2	2	Int.	□	0420L020B	18.5	20	70	6.0
	7	Int.	□	0420L040B	38.5	40	90	6.0
	11	Int.	□	0420L060B	58.5	60	110	6.0
	19	Int.	□	0420L090B	88.5	90	140	6.0
4.3	2	Int.	□	0430L020B	18.5	20	70	6.0
	6	Int.	□	0430L040B	38.5	40	90	6.0
	11	Int.	□	0430L060B	58.5	60	110	6.0
	18	Int.	□	0430L090B	88.5	90	140	6.0
4.4	2	Int.	□	0440L020B	18.5	20	70	6.0
	6	Int.	□	0440L040B	38.5	40	90	6.0
	11	Int.	□	0440L060B	58.5	60	110	6.0
	18	Int.	□	0440L090B	88.5	90	140	6.0
4.5	2	Int.	★	0450L020B	18.5	20	70	6.0
	6	Int.	★	0450L040B	38.5	40	90	6.0
	10	Int.	★	0450L060B	58.5	60	110	6.0
	17	Int.	★	0450L090B	88.5	90	140	6.0
4.6	2	Int.	□	0460L020B	19.0	20	70	6.0
	6	Int.	□	0460L040B	39.0	40	90	6.0
	10	Int.	□	0460L060B	59.0	60	110	6.0
	17	Int.	□	0460L090B	89.0	90	140	6.0
4.7	2	Int.	□	0470L020B	19.0	20	70	6.0
	6	Int.	□	0470L040B	39.0	40	90	6.0
	10	Int.	□	0470L060B	59.0	60	110	6.0
	16	Int.	□	0470L090B	89.0	90	140	6.0
4.8	1	Int.	□	0480L020B	19.0	20	70	6.0
	6	Int.	□	0480L040B	39.0	40	90	6.0
	10	Int.	□	0480L060B	59.0	60	110	6.0
	16	Int.	□	0480L090B	89.0	90	140	6.0
4.9	1	Int.	□	0490L020B	19.0	20	70	6.0
	5	Int.	□	0490L040B	39.0	40	90	6.0
	10	Int.	□	0490L060B	59.0	60	110	6.0
	16	Int.	□	0490L090B	89.0	90	140	6.0

Note) Please contact Mitsubishi Carbide for any geometry that is not in the brochure (e.g. different diameter and length).

- : Stock Standard.
- ★ : Stock Standard in Japan.
- : Non stock, produced to order only.

CUTTING CONDITIONS

D134

MHS DRILLS

DRILLING

Ø 3.0 ~ 4.9

D129

DRILLING (SOLID CARBIDE)

MHS

- Possible to machine high precision deep holes for resin and die casting moulds!
- Strong geometry for stable machining in hardened materials.



P M K S N H ✓

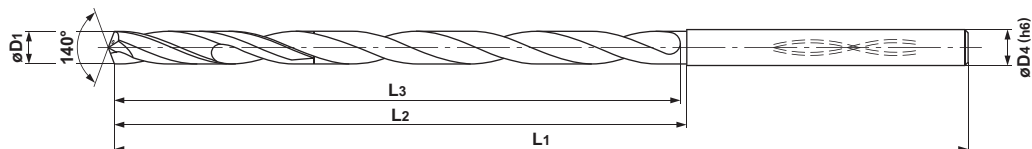

D1	3.0<D1≤6.0	6.0<D1≤10.0	10.0<D1≤12.0
Tolerance (mm)	+0.010 -0.002	+0.010 -0.005	+0.010 -0.008

Note 1) MHS drills are suitable for use with shrink fit holders.
 Note 2) Use the shortest type in the respective diameter as a pilot drill.

DRILLING MHS DRILLS

DRILLING
 Ø 5.0 ~
 6.8

Drill Dia. D1 (mm)	Hole Depth (l/d)	Coolant	Stock VP15TF	Order Number	Dimensions (mm)			
					L3	L2	L1	D4
5.0	1	Int.	★	MHS0500L020B	19.0	20	70	6.0
	5	Int.	★	0500L040B	39.0	40	90	6.0
	9	Int.	★	0500L060B	59.0	60	110	6.0
	15	Int.	★	0500L090B	89.0	90	140	6.0
	21	Int.	★	0500L120B	119.0	120	170	6.0
	27	Int.	★	0500L150B	149.0	150	200	6.0
5.1	3	Int.	□	0510L030B	29.5	30	80	6.0
	9	Int.	□	0510L060B	59.5	60	110	6.0
	15	Int.	□	0510L090B	89.5	90	140	6.0
	21	Int.	□	0510L120B	119.5	120	170	6.0
	27	Int.	□	0510L150B	149.5	150	200	6.0
5.2	3	Int.	□	0520L030B	29.5	30	80	6.0
	9	Int.	□	0520L060B	59.5	60	110	6.0
	15	Int.	□	0520L090B	89.5	90	140	6.0
	20	Int.	□	0520L120B	119.5	120	170	6.0
	26	Int.	□	0520L150B	149.5	150	200	6.0
5.3	3	Int.	□	0530L030B	29.5	30	80	6.0
	9	Int.	□	0530L060B	59.5	60	110	6.0
	14	Int.	□	0530L090B	89.5	90	140	6.0
	20	Int.	□	0530L120B	119.5	120	170	6.0
	26	Int.	□	0530L150B	149.5	150	200	6.0
5.4	3	Int.	□	0540L030B	29.5	30	80	6.0
	9	Int.	□	0540L060B	59.5	60	110	6.0
	14	Int.	□	0540L090B	89.5	90	140	6.0
	20	Int.	□	0540L120B	119.5	120	170	6.0
	25	Int.	□	0540L150B	149.5	150	200	6.0
5.5	3	Int.	★	0550L030B	29.5	30	80	6.0
	8	Int.	★	0550L060B	59.5	60	110	6.0
	14	Int.	★	0550L090B	89.5	90	140	6.0
	19	Int.	★	0550L120B	119.5	120	170	6.0
	25	Int.	★	0550L150B	149.5	150	200	6.0
5.6	3	Int.	□	0560L030B	30.0	30	80	6.0
	8	Int.	□	0560L060B	60.0	60	110	6.0
	14	Int.	□	0560L090B	90.0	90	140	6.0
	19	Int.	□	0560L120B	120.0	120	170	6.0
	24	Int.	□	0560L150B	150.0	150	200	6.0
5.7	3	Int.	□	0570L030B	30.0	30	80	6.0
	8	Int.	□	0570L060B	60.0	60	110	6.0
	13	Int.	□	0570L090B	90.0	90	140	6.0
	19	Int.	□	0570L120B	120.0	120	170	6.0
5.8	3	Int.	□	0580L030B	30.0	30	80	6.0
	8	Int.	□	0580L060B	60.0	60	110	6.0
	13	Int.	□	0580L090B	90.0	90	140	6.0
	18	Int.	□	0580L120B	120.0	120	170	6.0
	23	Int.	□	0580L150B	150.0	150	200	6.0
5.9	3	Int.	□	0590L030B	30.0	30	80	6.0
	8	Int.	□	0590L060B	60.0	60	110	6.0
	13	Int.	□	0590L090B	90.0	90	140	6.0
	18	Int.	□	0590L120B	120.0	120	170	6.0
	23	Int.	□	0590L150B	150.0	150	200	6.0

Drill Dia. D1 (mm)	Hole Depth (l/d)	Coolant	Stock VP15TF	Order Number	Dimensions (mm)			
					L3	L2	L1	D4
6.0	2	Int.	★	MHS0600L030B	30.0	30	80	6.0
	7	Int.	★	0600L060B	60.0	60	110	6.0
	12	Int.	★	0600L090B	90.0	90	140	6.0
	17	Int.	★	0600L120B	120.0	120	170	6.0
	22	Int.	★	0600L150B	150.0	150	200	6.0
6.1	2	Int.	□	0610L030B	28.5	30	80	8.0
	7	Int.	□	0610L060B	58.5	60	110	8.0
	12	Int.	□	0610L090B	88.5	90	140	8.0
	17	Int.	□	0610L120B	118.5	120	170	8.0
	22	Int.	□	0610L150B	148.5	150	200	8.0
6.2	2	Int.	□	0620L030B	28.5	30	80	8.0
	7	Int.	□	0620L060B	58.5	60	110	8.0
	12	Int.	□	0620L090B	88.5	90	140	8.0
	17	Int.	□	0620L120B	118.5	120	170	8.0
	21	Int.	□	0620L150B	148.5	150	200	8.0
6.3	2	Int.	□	0630L030B	28.5	30	80	8.0
	7	Int.	□	0630L060B	58.5	60	110	8.0
	12	Int.	□	0630L090B	88.5	90	140	8.0
	16	Int.	□	0630L120B	118.5	120	170	8.0
	21	Int.	□	0630L150B	148.5	150	200	8.0
6.4	2	Int.	□	0640L030B	28.5	30	80	8.0
	7	Int.	□	0640L060B	58.5	60	110	8.0
	11	Int.	□	0640L090B	88.5	90	140	8.0
	16	Int.	□	0640L120B	118.5	120	170	8.0
	21	Int.	□	0640L150B	148.5	150	200	8.0
6.5	2	Int.	★	0650L030B	28.5	30	80	8.0
	6	Int.	★	0650L060B	58.5	60	110	8.0
	11	Int.	★	0650L090B	88.5	90	140	8.0
	16	Int.	★	0650L120B	118.5	120	170	8.0
	20	Int.	★	0650L150B	148.5	150	200	8.0
6.6	2	Int.	□	0660L030B	29.0	30	80	8.0
	6	Int.	□	0660L060B	59.0	60	110	8.0
	11	Int.	□	0660L090B	89.0	90	140	8.0
	16	Int.	□	0660L120B	119.0	120	170	8.0
	20	Int.	□	0660L150B	149.0	150	200	8.0
	28	Int.	□	0660L200B	199.0	200	250	8.0
6.7	2	Int.	□	0670L030B	29.0	30	80	8.0
	6	Int.	□	0670L060B	59.0	60	110	8.0
	11	Int.	□	0670L090B	89.0	90	140	8.0
	15	Int.	□	0670L120B	119.0	120	170	8.0
	20	Int.	□	0670L150B	149.0	150	200	8.0
	27	Int.	□	0670L200B	199.0	200	250	8.0
6.8	2	Int.	□	0680L030B	29.0	30	80	8.0
	6	Int.	□	0680L060B	59.0	60	110	8.0
	11	Int.	□	0680L090B	89.0	90	140	8.0
	15	Int.	□	0680L120B	119.0	120	170	8.0
	19	Int.	□	0680L150B	149.0	150	200	8.0
	27	Int.	□	0680L200B	199.0	200	250	8.0

(Note) Please contact Mitsubishi Carbide for any geometry that is not in the brochure (e.g. different diameter and length).

- : Stock Standard
- ★ : Stock Standard in Japan.
- : Non stock, produced to order only

Drill Dia. D1 (mm)	Hole Depth (l/d)	Coolant	Stock VP15TF	Order Number	Dimensions (mm)			
					L3	L2	L1	D4
6.9	2	Int.	□	MHS0690L030B	29.0	30	80	8.0
	6	Int.	□	0690L060B	59.0	60	110	8.0
	10	Int.	□	0690L090B	89.0	90	140	8.0
	15	Int.	□	0690L120B	119.0	120	170	8.0
	19	Int.	□	0690L150B	149.0	150	200	8.0
26	Int.	□	0690L200B	199.0	200	250	8.0	
7.0	2	Int.	★	0700L030B	29.0	30	80	8.0
	6	Int.	★	0700L060B	59.0	60	110	8.0
	10	Int.	★	0700L090B	89.0	90	140	8.0
	14	Int.	★	0700L120B	119.0	120	170	8.0
	19	Int.	★	0700L150B	149.0	150	200	8.0
26	Int.	★	0700L200B	199.0	200	250	8.0	
7.1	2	Int.	□	0710L030B	29.5	30	80	8.0
	6	Int.	□	0710L060B	59.5	60	110	8.0
	10	Int.	□	0710L090B	89.5	90	140	8.0
	14	Int.	□	0710L120B	119.5	120	170	8.0
	19	Int.	□	0710L150B	149.5	150	200	8.0
26	Int.	□	0710L200B	199.5	200	250	8.0	
7.2	2	Int.	□	0720L030B	29.5	30	80	8.0
	6	Int.	□	0720L060B	59.5	60	110	8.0
	10	Int.	□	0720L090B	89.5	90	140	8.0
	14	Int.	□	0720L120B	119.5	120	170	8.0
	18	Int.	□	0720L150B	149.5	150	200	8.0
25	Int.	□	0720L200B	199.5	200	250	8.0	
7.3	2	Int.	□	0730L030B	29.5	30	80	8.0
	6	Int.	□	0730L060B	59.5	60	110	8.0
	10	Int.	□	0730L090B	89.5	90	140	8.0
	14	Int.	□	0730L120B	119.5	120	170	8.0
	18	Int.	□	0730L150B	149.5	150	200	8.0
25	Int.	□	0730L200B	199.5	200	250	8.0	
7.4	1	Int.	□	0740L030B	29.5	30	80	8.0
	6	Int.	□	0740L060B	59.5	60	110	8.0
	10	Int.	□	0740L090B	89.5	90	140	8.0
	14	Int.	□	0740L120B	119.5	120	170	8.0
	18	Int.	□	0740L150B	149.5	150	200	8.0
24	Int.	□	0740L200B	199.5	200	250	8.0	
7.5	1	Int.	★	0750L030B	29.5	30	80	8.0
	5	Int.	★	0750L060B	59.5	60	110	8.0
	9	Int.	★	0750L090B	89.5	90	140	8.0
	13	Int.	★	0750L120B	119.5	120	170	8.0
	17	Int.	★	0750L150B	149.5	150	200	8.0
24	Int.	★	0750L200B	199.5	200	250	8.0	
7.6	1	Int.	□	0760L030B	30.0	30	80	8.0
	5	Int.	□	0760L060B	60.0	60	110	8.0
	9	Int.	□	0760L090B	90.0	90	140	8.0
	13	Int.	□	0760L120B	120.0	120	170	8.0
	17	Int.	□	0760L150B	150.0	150	200	8.0
	24	Int.	□	0760L200B	200.0	200	250	8.0
30	Int.	□	0760L250B	250.0	250	300	8.0	
7.7	1	Int.	□	0770L030B	30.0	30	80	8.0
	5	Int.	□	0770L060B	60.0	60	110	8.0
	9	Int.	□	0770L090B	90.0	90	140	8.0
	13	Int.	□	0770L120B	120.0	120	170	8.0
	17	Int.	□	0770L150B	150.0	150	200	8.0
	23	Int.	□	0770L200B	200.0	200	250	8.0
30	Int.	□	0770L250B	250.0	250	300	8.0	
7.8	1	Int.	□	0780L030B	30.0	30	80	8.0
	5	Int.	□	0780L060B	60.0	60	110	8.0
	9	Int.	□	0780L090B	90.0	90	140	8.0
	13	Int.	□	0780L120B	120.0	120	170	8.0
	17	Int.	□	0780L150B	150.0	150	200	8.0
	23	Int.	□	0780L200B	200.0	200	250	8.0
30	Int.	□	0780L250B	250.0	250	300	8.0	
7.9	1	Int.	□	0790L030B	30.0	30	80	8.0
	5	Int.	□	0790L060B	60.0	60	110	8.0
	9	Int.	□	0790L090B	90.0	90	140	8.0
	13	Int.	□	0790L120B	120.0	120	170	8.0
	16	Int.	□	0790L150B	150.0	150	200	8.0
	23	Int.	□	0790L200B	200.0	200	250	8.0
29	Int.	□	0790L250B	250.0	250	300	8.0	

Drill Dia. D1 (mm)	Hole Depth (l/d)	Coolant	Stock VP15TF	Order Number	Dimensions (mm)			
					L3	L2	L1	D4
8.0	1	Int.	★	MHS0800L030B	30.0	30	80	8.0
	5	Int.	★	0800L060B	60.0	60	110	8.0
	9	Int.	★	0800L090B	90.0	90	140	8.0
	12	Int.	★	0800L120B	120.0	120	170	8.0
	16	Int.	★	0800L150B	150.0	150	200	8.0
	22	Int.	★	0800L200B	200.0	200	250	8.0
	29	Int.	★	0800L250B	250.0	250	300	8.0
8.1	2	Int.	□	0810L040B	38.5	40	100	10.0
	8	Int.	□	0810L090B	88.5	90	150	10.0
	12	Int.	□	0810L120B	118.5	120	180	10.0
	16	Int.	□	0810L150B	148.5	150	210	10.0
	22	Int.	□	0810L200B	198.5	200	260	10.0
28	Int.	□	0810L250B	248.5	250	310	10.0	
8.2	2	Int.	□	0820L040B	38.5	40	100	10.0
	8	Int.	□	0820L090B	88.5	90	150	10.0
	12	Int.	□	0820L120B	118.5	120	180	10.0
	16	Int.	□	0820L150B	148.5	150	210	10.0
	22	Int.	□	0820L200B	198.5	200	260	10.0
28	Int.	□	0820L250B	248.5	250	310	10.0	
8.3	2	Int.	□	0830L040B	38.5	40	100	10.0
	8	Int.	□	0830L090B	88.5	90	150	10.0
	12	Int.	□	0830L120B	118.5	120	180	10.0
	15	Int.	□	0830L150B	148.5	150	210	10.0
	21	Int.	□	0830L200B	198.5	200	260	10.0
27	Int.	□	0830L250B	248.5	250	310	10.0	
8.4	2	Int.	□	0840L040B	38.5	40	100	10.0
	8	Int.	□	0840L090B	88.5	90	150	10.0
	12	Int.	□	0840L120B	118.5	120	180	10.0
	15	Int.	□	0840L150B	148.5	150	210	10.0
	21	Int.	□	0840L200B	198.5	200	260	10.0
	27	Int.	□	0840L250B	248.5	250	310	10.0
8.5	2	Int.	★	0850L040B	38.5	40	100	10.0
	8	Int.	★	0850L090B	88.5	90	150	10.0
	11	Int.	★	0850L120B	118.5	120	180	10.0
	15	Int.	★	0850L150B	148.5	150	210	10.0
	21	Int.	★	0850L200B	198.5	200	260	10.0
	27	Int.	★	0850L250B	248.5	250	310	10.0
8.6	2	Int.	□	0860L040B	39.0	40	100	10.0
	8	Int.	□	0860L090B	89.0	90	150	10.0
	11	Int.	□	0860L120B	119.0	120	180	10.0
	15	Int.	□	0860L150B	149.0	150	210	10.0
	21	Int.	□	0860L200B	199.0	200	260	10.0
	26	Int.	□	0860L250B	249.0	250	310	10.0
8.7	2	Int.	□	0870L040B	39.0	40	100	10.0
	8	Int.	□	0870L090B	89.0	90	150	10.0
	11	Int.	□	0870L120B	119.0	120	180	10.0
	15	Int.	□	0870L150B	149.0	150	210	10.0
	20	Int.	□	0870L200B	199.0	200	260	10.0
	26	Int.	□	0870L250B	249.0	250	310	10.0
8.8	2	Int.	□	0880L040B	39.0	40	100	10.0
	8	Int.	□	0880L090B	89.0	90	150	10.0
	11	Int.	□	0880L120B	119.0	120	180	10.0
	14	Int.	□	0880L150B	149.0	150	210	10.0
	20	Int.	□	0880L200B	199.0	200	260	10.0
	26	Int.	□	0880L250B	249.0	250	310	10.0
8.9	2	Int.	□	0890L040B	39.0	40	100	10.0
	7	Int.	□	0890L090B	89.0	90	150	10.0
	11	Int.	□	0890L120B	119.0	120	180	10.0
	14	Int.	□	0890L150B	149.0	150	210	10.0
	20	Int.	□	0890L200B	199.0	200	260	10.0
25	Int.	□	0890L250B	249.0	250	310	10.0	
9.0	2	Int.	★	0900L040B	39.0	40	100	10.0
	7	Int.	★	0900L090B	89.0	90	150	10.0
	11	Int.	★	0900L120B	119.0	120	180	10.0
	14	Int.	★	0900L150B	149.0	150	210	10.0
	20	Int.	★	0900L200B	199.0	200	260	10.0
25	Int.	★	0900L250B	249.0	250	310	10.0	



DRILLING (SOLID CARBIDE)

MHS

- Possible to machine high precision deep holes for resin and die casting moulds!
- Strong geometry for stable machining in hardened materials.



P	M	K	S	N	H	✓
----------	----------	----------	----------	----------	----------	---



D1	3.0 ≤ D1 ≤ 6.0	6.0 < D1 ≤ 10.0	10.0 < D1 ≤ 12.0
Tolerance (mm)	+0.010 -0.002	+0.010 -0.005	+0.010 -0.008

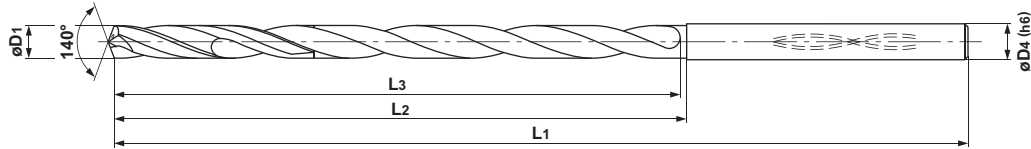

Note 1) MHS drills are suitable for use with shrink fit holders.
 Note 2) Use the shortest type in the respective diameter as a pilot drill.

Drill Dia. D1 (mm)	Hole Depth (l/d)	Coolant	Stock VP15TF	Order Number	Dimensions (mm)			
					L3	L2	L1	D4
9.1	2	Int.	□	MHS0910L040B	39.5	40	100	10.0
	7	Int.	□	0910L090B	89.5	90	150	10.0
	11	Int.	□	0910L120B	119.5	120	180	10.0
	14	Int.	□	0910L150B	149.5	150	210	10.0
	19	Int.	□	0910L200B	199.5	200	260	10.0
	25	Int.	□	0910L250B	249.5	250	310	10.0
30	Int.	□	0910L300B	299.5	300	360	10.0	
9.2	2	Int.	□	0920L040B	39.5	40	100	10.0
	7	Int.	□	0920L090B	89.5	90	150	10.0
	10	Int.	□	0920L120B	119.5	120	180	10.0
	14	Int.	□	0920L150B	149.5	150	210	10.0
	19	Int.	□	0920L200B	199.5	200	260	10.0
	25	Int.	□	0920L250B	249.5	250	310	10.0
30	Int.	□	0920L300B	299.5	300	360	10.0	
9.3	2	Int.	□	0930L040B	39.5	40	100	10.0
	7	Int.	□	0930L090B	89.5	90	150	10.0
	10	Int.	□	0930L120B	119.5	120	180	10.0
	14	Int.	□	0930L150B	149.5	150	210	10.0
	19	Int.	□	0930L200B	199.5	200	260	10.0
	24	Int.	□	0930L250B	249.5	250	310	10.0
30	Int.	□	0930L300B	299.5	300	360	10.0	
9.4	2	Int.	□	0940L040B	39.5	40	100	10.0
	7	Int.	□	0940L090B	89.5	90	150	10.0
	10	Int.	□	0940L120B	119.5	120	180	10.0
	13	Int.	□	0940L150B	149.5	150	210	10.0
	19	Int.	□	0940L200B	199.5	200	260	10.0
	24	Int.	□	0940L250B	249.5	250	310	10.0
29	Int.	□	0940L300B	299.5	300	360	10.0	
9.5	2	Int.	★	0950L040B	39.5	40	100	10.0
	7	Int.	★	0950L090B	89.5	90	150	10.0
	10	Int.	★	0950L120B	119.5	120	180	10.0
	13	Int.	★	0950L150B	149.5	150	210	10.0
	18	Int.	★	0950L200B	199.5	200	260	10.0
	24	Int.	★	0950L250B	249.5	250	310	10.0
29	Int.	★	0950L300B	299.5	300	360	10.0	
9.6	2	Int.	□	0960L040B	40.0	40	100	10.0
	7	Int.	□	0960L090B	90.0	90	150	10.0
	10	Int.	□	0960L120B	120.0	120	180	10.0
	13	Int.	□	0960L150B	150.0	150	210	10.0
	18	Int.	□	0960L200B	200.0	200	260	10.0
	24	Int.	□	0960L250B	250.0	250	310	10.0
29	Int.	□	0960L300B	300.0	300	360	10.0	
9.7	2	Int.	□	0970L040B	40.0	40	100	10.0
	7	Int.	□	0970L090B	90.0	90	150	10.0
	10	Int.	□	0970L120B	120.0	120	180	10.0
	13	Int.	□	0970L150B	150.0	150	210	10.0
	18	Int.	□	0970L200B	200.0	200	260	10.0
	23	Int.	□	0970L250B	250.0	250	310	10.0
28	Int.	□	0970L300B	300.0	300	360	10.0	

Drill Dia. D1 (mm)	Hole Depth (l/d)	Coolant	Stock VP15TF	Order Number	Dimensions (mm)			
					L3	L2	L1	D4
9.8	2	Int.	□	MHS0980L040B	40.0	40	100	10.0
	7	Int.	□	0980L090B	90.0	90	150	10.0
	10	Int.	□	0980L120B	120.0	120	180	10.0
	13	Int.	□	0980L150B	150.0	150	210	10.0
	18	Int.	□	0980L200B	200.0	200	260	10.0
	23	Int.	□	0980L250B	250.0	250	310	10.0
28	Int.	□	0980L300B	300.0	300	360	10.0	
9.9	2	Int.	□	0990L040B	40.0	40	100	10.0
	7	Int.	□	0990L090B	90.0	90	150	10.0
	10	Int.	□	0990L120B	120.0	120	180	10.0
	13	Int.	□	0990L150B	150.0	150	210	10.0
	18	Int.	□	0990L200B	200.0	200	260	10.0
	23	Int.	□	0990L250B	250.0	250	310	10.0
28	Int.	□	0990L300B	300.0	300	360	10.0	
10.0	1	Int.	★	1000L040B	40.0	40	100	10.0
	6	Int.	★	1000L090B	90.0	90	150	10.0
	9	Int.	★	1000L120B	120.0	120	180	10.0
	12	Int.	★	1000L150B	150.0	150	210	10.0
	17	Int.	★	1000L200B	200.0	200	260	10.0
	22	Int.	★	1000L250B	250.0	250	310	10.0
27	Int.	★	1000L300B	300.0	300	360	10.0	
10.1	1	Int.	□	1010L040B	38.5	40	100	12.0
	6	Int.	□	1010L090B	88.5	90	150	12.0
	9	Int.	□	1010L120B	118.5	120	180	12.0
	12	Int.	□	1010L150B	148.5	150	210	12.0
	17	Int.	□	1010L200B	198.5	200	260	12.0
	22	Int.	□	1010L250B	248.5	250	310	12.0
27	Int.	□	1010L300B	298.5	300	360	12.0	
10.2	1	Int.	□	1020L040B	38.5	40	100	12.0
	6	Int.	□	1020L090B	88.5	90	150	12.0
	9	Int.	□	1020L120B	118.5	120	180	12.0
	12	Int.	□	1020L150B	148.5	150	210	12.0
	17	Int.	□	1020L200B	198.5	200	260	12.0
	22	Int.	□	1020L250B	248.5	250	310	12.0
27	Int.	□	1020L300B	298.5	300	360	12.0	
10.3	1	Int.	□	1030L040B	38.5	40	100	12.0
	6	Int.	□	1030L090B	88.5	90	150	12.0
	9	Int.	□	1030L120B	118.5	120	180	12.0
	12	Int.	□	1030L150B	148.5	150	210	12.0
	17	Int.	□	1030L200B	198.5	200	260	12.0
	22	Int.	□	1030L250B	248.5	250	310	12.0
26	Int.	□	1030L300B	298.5	300	360	12.0	
10.4	1	Int.	□	1040L040B	38.5	40	100	12.0
	6	Int.	□	1040L090B	88.5	90	150	12.0
	9	Int.	□	1040L120B	118.5	120	180	12.0
	12	Int.	□	1040L150B	148.5	150	210	12.0
	17	Int.	□	1040L200B	198.5	200	260	12.0
	21	Int.	□	1040L250B	248.5	250	310	12.0
26	Int.	□	1040L300B	298.5	300	360	12.0	

Note) Please contact Mitsubishi Carbide for any geometry that is not in the brochure (e.g. different diameter and length).

- : Stock Standard.
- ★ : Stock Standard in Japan.
- : Non stock, produced to order only.

Drill Dia. D1 (mm)	Hole Depth (l/d)	Coolant	Stock VP15TF	Order Number	Dimensions (mm)			
					L3	L2	L1	D4
10.5	1	Int.	★	MHS1050L040B	38.5	40	100	12.0
	6	Int.	★	1050L090B	88.5	90	150	12.0
	9	Int.	★	1050L120B	118.5	120	180	12.0
	12	Int.	★	1050L150B	148.5	150	210	12.0
	16	Int.	★	1050L200B	198.5	200	260	12.0
	21	Int.	★	1050L250B	248.5	250	310	12.0
26	Int.	★	1050L300B	298.5	300	360	12.0	
10.6	1	Int.	□	1060L040B	39.0	40	100	12.0
	6	Int.	□	1060L090B	89.0	90	150	12.0
	9	Int.	□	1060L120B	119.0	120	180	12.0
	12	Int.	□	1060L150B	149.0	150	210	12.0
	16	Int.	□	1060L200B	199.0	200	260	12.0
	21	Int.	□	1060L250B	249.0	250	310	12.0
26	Int.	□	1060L300B	299.0	300	360	12.0	
10.7	1	Int.	□	1070L040B	39.0	40	100	12.0
	6	Int.	□	1070L090B	89.0	90	150	12.0
	9	Int.	□	1070L120B	119.0	120	180	12.0
	11	Int.	□	1070L150B	149.0	150	210	12.0
	16	Int.	□	1070L200B	199.0	200	260	12.0
	21	Int.	□	1070L250B	249.0	250	310	12.0
25	Int.	□	1070L300B	299.0	300	360	12.0	
10.8	1	Int.	□	1080L040B	39.0	40	100	12.0
	6	Int.	□	1080L090B	89.0	90	150	12.0
	9	Int.	□	1080L120B	119.0	120	180	12.0
	11	Int.	□	1080L150B	149.0	150	210	12.0
	16	Int.	□	1080L200B	199.0	200	260	12.0
	21	Int.	□	1080L250B	249.0	250	310	12.0
25	Int.	□	1080L300B	299.0	300	360	12.0	
10.9	1	Int.	□	1090L040B	39.0	40	100	12.0
	6	Int.	□	1090L090B	89.0	90	150	12.0
	8	Int.	□	1090L120B	119.0	120	180	12.0
	11	Int.	□	1090L150B	149.0	150	210	12.0
	16	Int.	□	1090L200B	199.0	200	260	12.0
	20	Int.	□	1090L250B	249.0	250	310	12.0
25	Int.	□	1090L300B	299.0	300	360	12.0	
11.0	1	Int.	★	1100L040B	39.0	40	100	12.0
	6	Int.	★	1100L090B	89.0	90	150	12.0
	8	Int.	★	1100L120B	119.0	120	180	12.0
	11	Int.	★	1100L150B	149.0	150	210	12.0
	16	Int.	★	1100L200B	199.0	200	260	12.0
	20	Int.	★	1100L250B	249.0	250	310	12.0
25	Int.	★	1100L300B	299.0	300	360	12.0	
11.1	1	Int.	□	1110L040B	39.5	40	100	12.0
	6	Int.	□	1110L090B	89.5	90	150	12.0
	8	Int.	□	1110L120B	119.5	120	180	12.0
	11	Int.	□	1110L150B	149.5	150	210	12.0
	15	Int.	□	1110L200B	199.5	200	260	12.0
	20	Int.	□	1110L250B	249.5	250	310	12.0
24	Int.	□	1110L300B	299.5	300	360	12.0	
11.2	1	Int.	□	1120L040B	39.5	40	100	12.0
	5	Int.	□	1120L090B	89.5	90	150	12.0
	8	Int.	□	1120L120B	119.5	120	180	12.0
	11	Int.	□	1120L150B	149.5	150	210	12.0
	15	Int.	□	1120L200B	199.5	200	260	12.0
	20	Int.	□	1120L250B	249.5	250	310	12.0
24	Int.	□	1120L300B	299.5	300	360	12.0	

Drill Dia. D1 (mm)	Hole Depth (l/d)	Coolant	Stock VP15TF	Order Number	Order Number			
					L3	L2	L1	D4
11.3	1	Int.	□	MHS1130L040B	39.5	40	100	12.0
	5	Int.	□	1130L090B	89.5	90	150	12.0
	8	Int.	□	1130L120B	119.5	120	180	12.0
	11	Int.	□	1130L150B	149.5	150	210	12.0
	15	Int.	□	1130L200B	199.5	200	260	12.0
	20	Int.	□	1130L250B	249.5	250	310	12.0
24	Int.	□	1130L300B	299.5	300	360	12.0	
11.4	1	Int.	□	1140L040B	39.5	40	100	12.0
	5	Int.	□	1140L090B	89.5	90	150	12.0
	8	Int.	□	1140L120B	119.5	120	180	12.0
	11	Int.	□	1140L150B	149.5	150	210	12.0
	15	Int.	□	1140L200B	199.5	200	260	12.0
	19	Int.	□	1140L250B	249.5	250	310	12.0
24	Int.	□	1140L300B	299.5	300	360	12.0	
11.5	1	Int.	★	1150L040B	39.5	40	100	12.0
	5	Int.	★	1150L090B	89.5	90	150	12.0
	8	Int.	★	1150L120B	119.5	120	180	12.0
	10	Int.	★	1150L150B	149.5	150	210	12.0
	15	Int.	★	1150L200B	199.5	200	260	12.0
	19	Int.	★	1150L250B	249.5	250	310	12.0
24	Int.	★	1150L300B	299.5	300	360	12.0	
11.6	1	Int.	□	1160L040B	40.0	40	100	12.0
	5	Int.	□	1160L090B	90.0	90	150	12.0
	8	Int.	□	1160L120B	120.0	120	180	12.0
	10	Int.	□	1160L150B	150.0	150	210	12.0
	15	Int.	□	1160L200B	200.0	200	260	12.0
	19	Int.	□	1160L250B	250.0	250	310	12.0
23	Int.	□	1160L300B	300.0	300	360	12.0	
11.7	1	Int.	□	1170L040B	40.0	40	100	12.0
	5	Int.	□	1170L090B	90.0	90	150	12.0
	8	Int.	□	1170L120B	120.0	120	180	12.0
	10	Int.	□	1170L150B	150.0	150	210	12.0
	15	Int.	□	1170L200B	200.0	200	260	12.0
	19	Int.	□	1170L250B	250.0	250	310	12.0
23	Int.	□	1170L300B	300.0	300	360	12.0	
11.8	1	Int.	□	1180L040B	40.0	40	100	12.0
	5	Int.	□	1180L090B	90.0	90	150	12.0
	8	Int.	□	1180L120B	120.0	120	180	12.0
	10	Int.	□	1180L150B	150.0	150	210	12.0
	14	Int.	□	1180L200B	200.0	200	260	12.0
	19	Int.	□	1180L250B	250.0	250	310	12.0
23	Int.	□	1180L300B	300.0	300	360	12.0	
11.9	1	Int.	□	1190L040B	40.0	40	100	12.0
	5	Int.	□	1190L090B	90.0	90	150	12.0
	8	Int.	□	1190L120B	120.0	120	180	12.0
	10	Int.	□	1190L150B	150.0	150	210	12.0
	14	Int.	□	1190L200B	200.0	200	260	12.0
	19	Int.	□	1190L250B	250.0	250	310	12.0
23	Int.	□	1190L300B	300.0	300	360	12.0	
12.0	1	Int.	★	1200L040B	40.0	40	100	12.0
	5	Int.	★	1200L090B	90.0	90	150	12.0
	7	Int.	★	1200L120B	120.0	120	180	12.0
	10	Int.	★	1200L150B	150.0	150	210	12.0
	14	Int.	★	1200L200B	200.0	200	260	12.0
	18	Int.	★	1200L250B	250.0	250	310	12.0
22	Int.	★	1200L300B	300.0	300	360	12.0	



Recommended Cutting Conditions

Work Material	Drill Diameter Conditions Hardness	$\phi 3.0 - \phi 6.0$		$\phi 6.0 - \phi 10.0$		$\phi 10.0 - \phi 12.0$	
		Cutting Speed (m/min)	Feed (mm/rev)	Cutting Speed (m/min)	Feed (mm/rev)	Cutting Speed (m/min)	Feed (mm/rev)
H Heat-treated steel Pre-hardened steel	-40HRC	40-70	0.10-0.20	40-70	0.15-0.25	40-70	0.20-0.30
	40-50HRC	20-50	0.05-0.15	20-50	0.10-0.20	20-50	0.15-0.25
	50-55HRC	10-30	0.03-0.10	10-30	0.05-0.15	10-30	0.05-0.20

Note 1) When using a drill with a length over l/d 10, it is necessary to use a pilot hole as a guide.

(If no pilot-hole is used then drill breakage can occur)

Note 2) Use the shortest flute drill in the respective size as a pilot drill.

RECOMMENDED CUTTING CONDITIONS FOR MHS



DRILLING

CUTTING DATA



HOW TO USE LONG TYPE DRILLS

● Drilling a blind hole

■ 1. Drilling a pilot hole

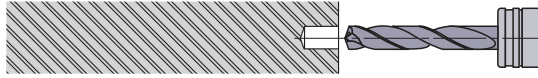

- ① Use the shortest MHS-Drill as pilot drill.
- ② Use a drill with the same diameter as the deep hole drill.
- ③ Drill depth : Approx 2–3D or deeper.
(Adjust the pilot hole depth according to the length of the super long type.)

■ 2. Initial cutting with the long type drill

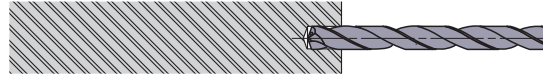

- ① Penetrate the pilot hole at low revolution. (Cutting speed 20–30m/min, feed rate 0.2–0.3mm/rev)
- ② Stop the long type drill 1–3mm short of the pilot hole bottom.

■ 3. Drill the deep hole

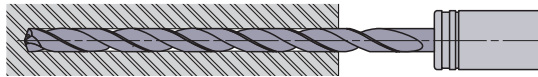

- ① Start cutting at the recommended speed and feed with a non-peck (continuous feed) cycle.

■ 4. Drill retraction

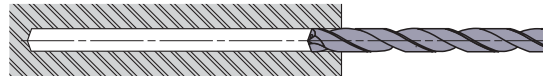

- ① After drilling, lower the cutting revolution about 1–2mm short of the hole end. (Cutting speed of around 20–30m/min)
- ② Retract the drill to the pilot hole depth starting point at a feed rate of 3000mm/min.
- ③ Finally, clear the hole at a cutting speed of 20–30m/min and feed rate of 0.2–0.3mm/rev.

● Drilling and breaking through on irregular faces or angles

■ 1. Spot facing

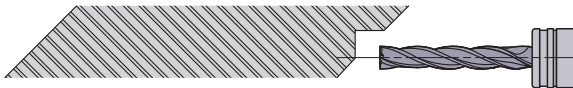

- ① Machine a flat or the irregular face by using an end mill or slot drill capable of spot facing. Make the spot face diameter the same size as the required deep hole diameter.

■ 2. Drilling a pilot hole

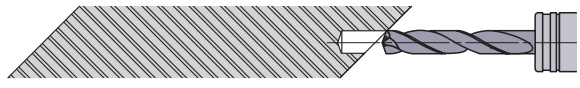

- ① Use the shortest MHS-Drill as pilot drill.
- ② Use a drill with the same diameter as the deep hole drill.
- ③ Drill depth : Approx 2–3D or deeper.
(Adjust the pilot hole depth according to the length of the super long type.)

■ 3. Initial cutting with the long type drill

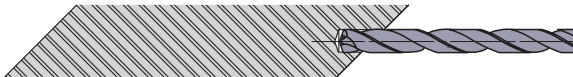

- ① Penetrate the pilot hole at a low revolution. (Cutting speed 20–30m/min, feed rate 0.2–0.3mm/rev)
- ② Stop the long type drill 1–3mm short of the pilot hole bottom.

■ 4. Drill the deep hole

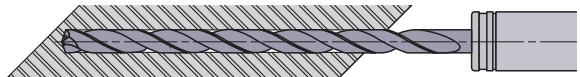

- ① Start cutting at the recommended speed and feed with a non-peck (continuous feed) cycle.

■ 5. Breaking through

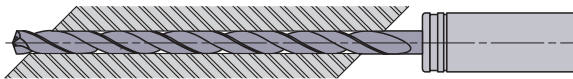

- ① When breaking through, the cutting edge can be damaged.
- ② A feed rate of 0.05–0.1mm/rev is recommended.

■ 6. Drill retraction

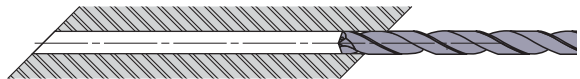

- ① Retract the drill to the pilot hole depth starting point at a feed rate of 3000mm/min.
- ② Finally clear the hole at a cutting speed of 20–30m/min and feed rate of 0.2–0.3mm/rev.



VCHSM

Solid Carbide drill for hardened steel up to 65HRC.
High tool rigidity with good chip discharge.



PRECISION
FOR SUCCESS

CHOOSE JAPAN'S NO. 1

MITSUBISHI
MITSUBISHI MATERIALS

www.mitsubishicarbide.com

Solid carbide drill for hardened steel

VCHSM

Features

Helix flute

Achieves high tool rigidity and good chip discharge due to a small helix angle and a unique flute shape.

Cutting edge

The same tough straight cutting edge is used as in previous drill series.

X Thinning

The X thinning enables easy initial cutting, which leads to high accuracy machining.

Three relief faces

Enables easy re-grinding due to the three rake cutting edge geometry.

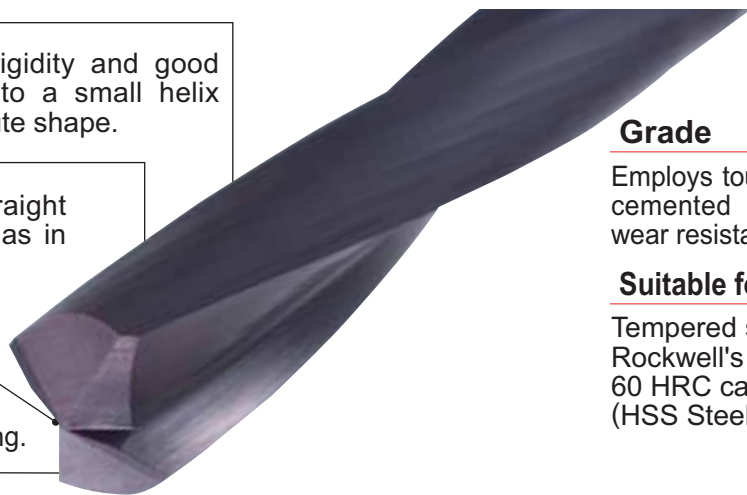

Grade

Employs tough TF15 micro-grain cemented carbide and highly wear resistant VP coating.

Suitable for hardened steel

Tempered steel with a Rockwell's hardness up to 60 HRC can be machined. (HSS Steel can be drilled!)



Cutting Performance

● Cutting resistance Workpiece : X100CrMoV5 1 (60HRC) Cutting speed : 10m/min Depth of cut : l/d=3(through hole) Coolant : Water soluble emulsion(10%)

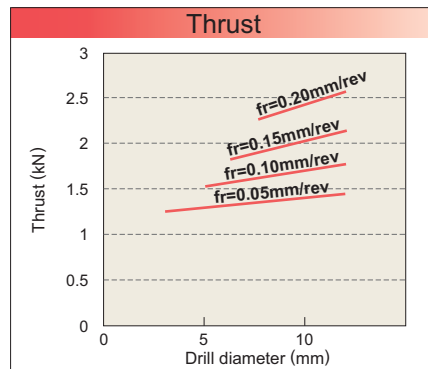
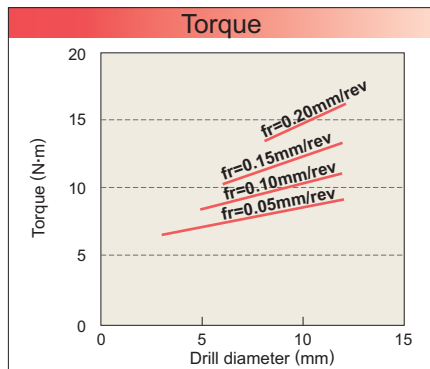
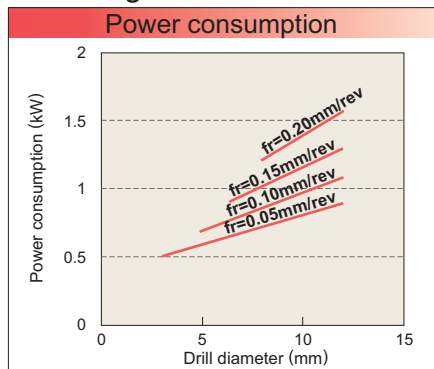

● Cutting accuracy Tool : VCHSMD1000 Workpiece : X100CrMoV5 1(60HRC) Depth of cut : l/d=3(through hole) Coolant : Water soluble emulsion(10%)

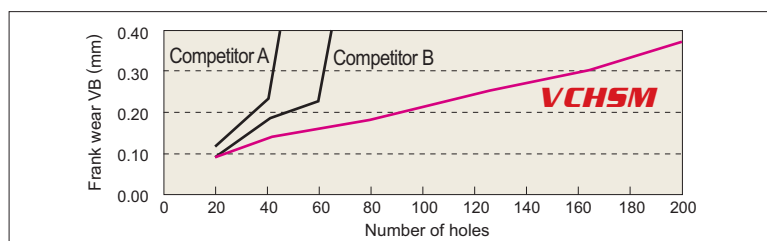
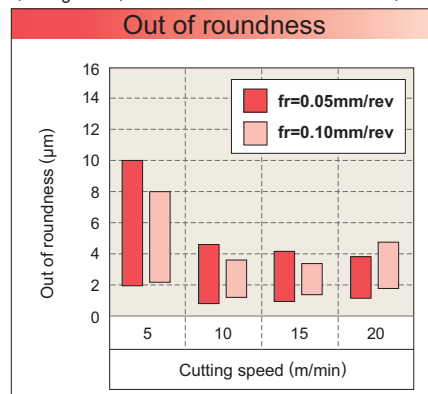
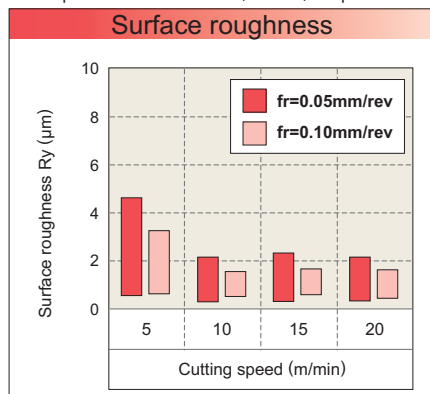
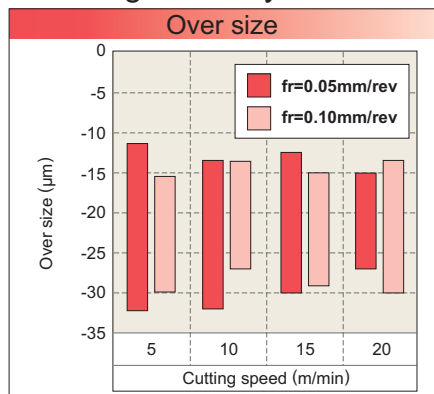

<Cutting conditions>

Tool : VCHSMD1000
 Workpiece : X100CrMoV5 1 (60HRC)
 Cutting speed : 10m/min
 Feed : 0.05mm/rev
 Hole depth : 30mm (l/d=3) Blind hole
 Coolant : Water soluble emulsion (10%)

DRILLING (SOLID CARBIDE)

VCHSM

- For hardened steel.
- High rigidity, high accuracy and long tool life.



P	M	K	S	N	H	✓
----------	----------	----------	----------	----------	----------	---

D1(h8)	D1≤3.0	3.0<D1≤6.0	6.0<D1≤10.0	10.0<D1≤18.0
Tolerance	0 -0.014	0 -0.018	0 -0.022	0 -0.027

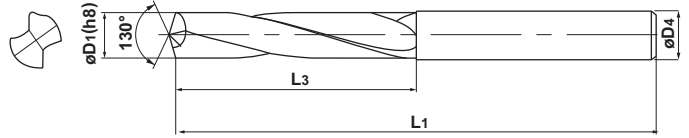

VCHSM DRILLS

DRILLING

 Ø 2.5 ~ 16.0

Drill Dia. D1 (mm)	Hole Depth (l/d)	Coolant (Int./Ext.)	Stock VP15TF	Order Number	Dimensions (mm)		
					D4	L1	L3
2.5	3	Ext.	★	VCHSMD0250	2.5	55	20
2.6	3	Ext.	★	D0260	2.6	55	20
2.7	3	Ext.	★	D0270	2.7	55	20
2.8	3	Ext.	★	D0280	2.8	60	21
2.9	3	Ext.	★	D0290	2.9	60	21
3.0	3	Ext.	★	D0300	3.0	60	21
3.1	3	Ext.	★	D0310	3.1	60	24
3.2	3	Ext.	★	D0320	3.2	60	24
3.3	3	Ext.	★	D0330	3.3	60	24
3.4	3	Ext.	★	D0340	3.4	60	24
3.5	3	Ext.	★	D0350	3.5	60	24
3.6	3	Ext.	★	D0360	3.6	60	27
3.7	3	Ext.	★	D0370	3.7	60	27
3.8	3	Ext.	★	D0380	3.8	60	27
3.9	3	Ext.	★	D0390	3.9	60	27
4.0	3	Ext.	★	D0400	4.0	60	27
4.1	3	Ext.	★	D0410	4.1	63	29
4.2	3	Ext.	★	D0420	4.2	63	29
4.3	3	Ext.	★	D0430	4.3	63	29
4.4	3	Ext.	★	D0440	4.4	63	29
4.5	3	Ext.	★	D0450	4.5	63	29
4.6	3	Ext.	★	D0460	4.6	68	32
4.7	3	Ext.	★	D0470	4.7	68	32
4.8	3	Ext.	★	D0480	4.8	68	32
4.9	3	Ext.	★	D0490	4.9	68	32
5.0	3	Ext.	★	D0500	5.0	68	32
5.1	3	Ext.	★	D0510	5.1	72	34
5.2	3	Ext.	★	D0520	5.2	72	34
5.3	3	Ext.	★	D0530	5.3	72	34
5.4	3	Ext.	★	D0540	5.4	72	34
5.5	3	Ext.	★	D0550	5.5	72	34
5.6	3	Ext.	★	D0560	5.6	74	36
5.7	3	Ext.	★	D0570	5.7	74	36
5.8	3	Ext.	★	D0580	5.8	74	36
5.9	3	Ext.	★	D0590	5.9	74	36

Drill Dia. D1 (mm)	Hole Depth (l/d)	Coolant (Int./Ext.)	Stock VP15TF	Order Number	Dimensions (mm)		
					D4	L1	L3
6.0	3	Ext.	★	VCHSMD0600	6.0	81	41
6.5	3	Ext.	★	D0650	6.5	81	41
6.9	3	Ext.	★	D0690	6.9	83	43
7.0	3	Ext.	★	D0700	7.0	83	43
7.5	3	Ext.	★	D0750	7.5	87	45
8.0	3	Ext.	★	D0800	8.0	90	48
8.5	3	Ext.	★	D0850	8.5	96	53
8.6	3	Ext.	★	D0860	8.6	98	55
9.0	3	Ext.	★	D0900	9.0	98	55
9.5	3	Ext.	★	D0950	9.5	102	58
10.0	3	Ext.	★	D1000	10.0	105	60
10.4	3	Ext.	★	D1040	10.4	112	66
10.5	3	Ext.	★	D1050	10.5	112	66
11.0	3	Ext.	★	D1100	11.0	114	68
11.5	3	Ext.	★	D1150	11.5	118	71
12.0	3	Ext.	★	D1200	12.0	121	73
12.5	3	Ext.	★	D1250	12.5	135	76
13.0	3	Ext.	★	D1300	13.0	137	78
13.5	3	Ext.	★	D1350	13.5	144	84
14.0	3	Ext.	★	D1400	14.0	147	86
14.5	3	Ext.	★	D1450	14.5	151	89
15.0	3	Ext.	★	D1500	15.0	153	91
15.5	3	Ext.	★	D1550	15.5	157	94
16.0	3	Ext.	★	D1600	16.0	160	96

- : Stock Standard
- ★ : Stock Standard in Japan.
- : Non stock, produced to order only

RECOMMENDED CUTTING CONDITIONS

Work Material	Hardness (HRC)	Drill Dia. $\phi 2.5-\phi 5.0$		Drill Dia. $\phi 5.1-\phi 10.0$		Drill Dia. $\phi 10.1-\phi 16.0$	
		Cutting Speed (m/min)	Feed (mm/rev)	Cutting Speed (m/min)	Feed (mm/rev)	Cutting Speed (m/min)	Feed (mm/rev)
P Alloy Tool Steel High Speed Tool Steel	50-55	15 (10-20)	0.08 (0.05-0.10)	20 (15-25)	0.12 (0.08-0.15)	25 (20-30)	0.15 (0.10-0.18)
	55-60	10 (5-15)	0.04 (0.02-0.06)	15 (10-20)	0.06 (0.04-0.08)	20 (10-25)	0.08 (0.05-0.12)

Application examples

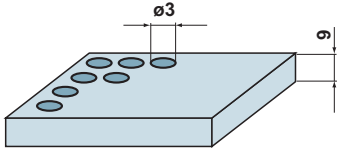
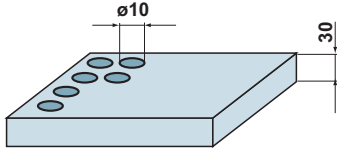
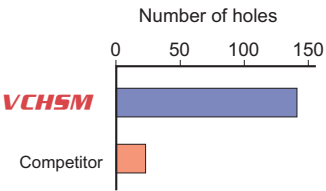
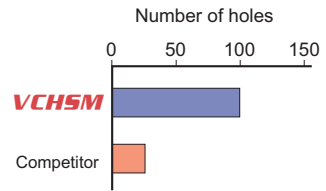
Tool		VCHSMD0300	VCHSMD1000
Workpiece		ASTM D2 (60HRC) 	ASTM D2 (60HRC) 
Component		Plate	Plate
Cutting conditions	Cutting speed (mm/min)	10	15
	Feed (mm/rev)	0.04	0.05
	Spindle speed (min ⁻¹)	1,060	477
	Table feed (mm/min)	42	24
Coolant		WSO	WSO
Results		● Tool life 	● Tool life 



MHE

Special Solid Carbide Drill for high precision drilling operations. Ideal for wheel hub drilling where superior hole accuracy is required.



PRECISION
FOR SUCCESS

CHOOSE JAPAN'S NO. 1

MITSUBISHI
MITSUBISHI MATERIALS

www.mitsubishicarbide.com

Solid Carbide Drill for high accuracy

MHE

Outline

For machining bolt holes of hubs, general-purpose drills are widely used, but are not highly productive due to the following problems.

- Elongated chips damage the periphery of the holes and lead to poor surface finishes.
- Plastic deformation can occur leading to a work hardened layer in the wall of the hole. This can result in a poor press fitting of the hub bolts.
- Due to the poor surface finish, a reaming operation maybe required to finish the holes.

MHE solid carbide drills overcome the above problems with excellent chip control and offer efficient, high precision drilling due to the use of low resistance cutting edges and a low helix angle.

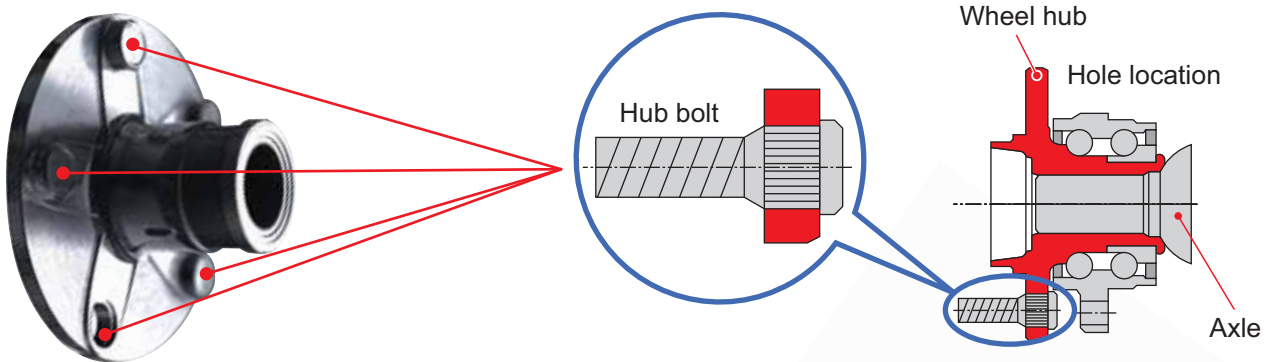

Features

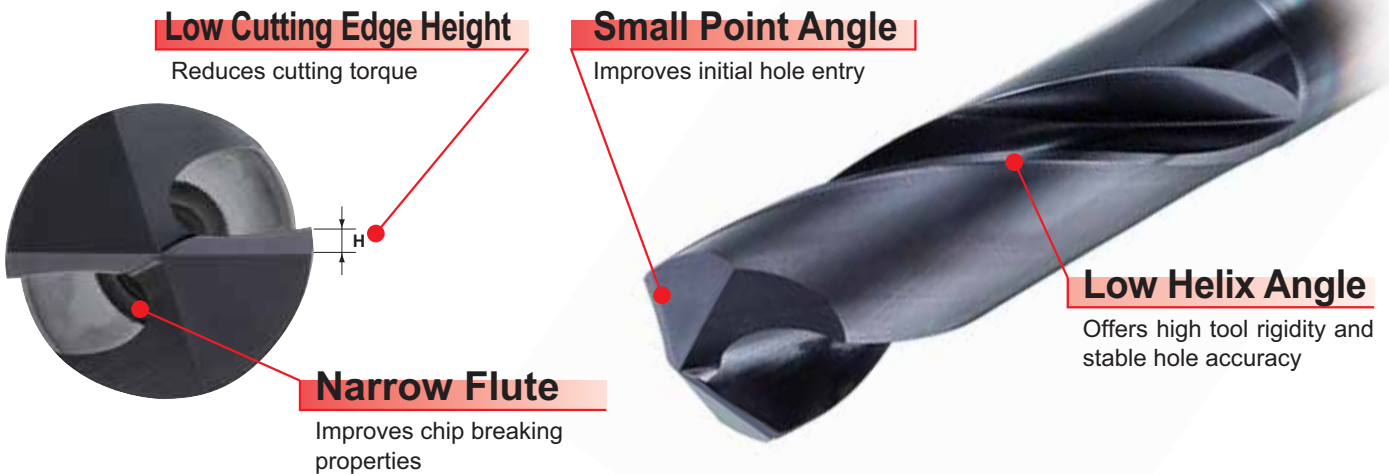

MHE DRILLS



FEATURES

Low Cutting Edge Height

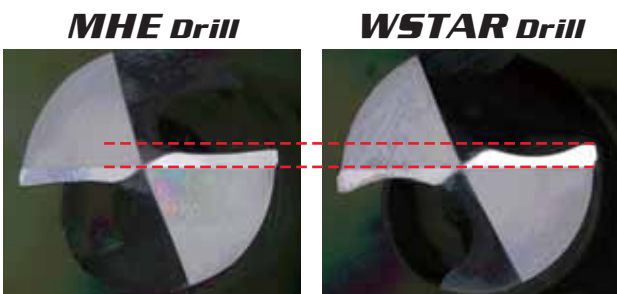

Reduces cutting torque

Narrow Flute

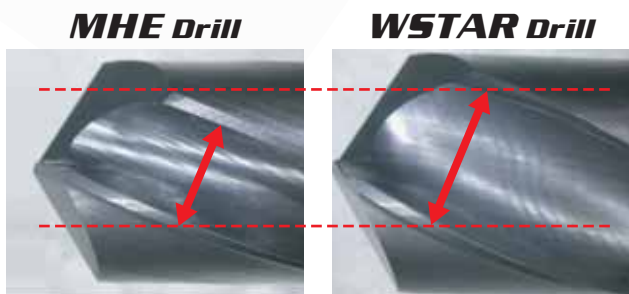

Breaks the chips into fine pieces

DRILLING (SOLID CARBIDE)

MHE



P ✓ **M** **K** **S** **N** **H**

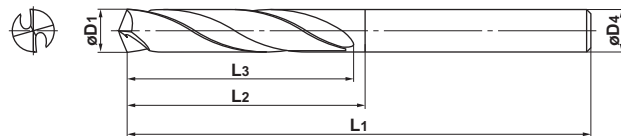

Drill Dia. D1 (mm)	Stock		Dimensions (mm)		
	VP15TF		L3	L1	L2
10.0—10.2	◇		43	87	43
10.2—10.5	◇		43	87	43
10.5—10.7	◇		43	87	43
10.7—11.0	◇		47	93	47
11.0—11.2	◇		47	93	47
11.2—11.5	◇		47	93	47
11.5—11.9	◇		47	93	47
11.9—12.0	◇		51	100	51
12.0—12.5	◇		51	100	51
12.5—13.0	◇		51	100	51

Drill Dia. D1 (mm)	Stock		Dimensions (mm)		
	VP15TF		L3	L1	L2
13.0—13.5	◇		54	104	54
13.5—14.0	◇		54	104	54
14.0—14.2	◇		56	104	56
14.2—14.5	◇		56	108	56
14.5—15.0	◇		56	108	56
15.0—15.5	◇		58	112	58
15.5—16.0	◇		58	112	58
16.0—16.5	◇		60	116	60
16.5—17.0	◇		60	116	60
17.0—17.5	◇		62	119	62
17.5—18.0	◇		62	119	62

Note) Contact Mitsubishi Materials for any geometry that is not shown above.

DRILLING MHE DRILLS

Product Range

Drill dia. : $\phi 10\text{--}\phi 18\text{mm}$

Drilling depth: $L/D \leq 1$ (L: hole depth; D: drill dia.)

Dimensions : Flute length is less than 4 times the drill diameter; Shank length will be determined based on present standards.

Tool grade : VP15TF

Notes When Regrinding and Recoating the Drill

- When carrying out regrinding, it is necessary to recoat the drill to maintain tool life.
- When requesting regrinding and recoating of the drill, contact Mitsubishi Materials sales staff.

● : Stock Standard.
 ★ : Stock Standard in Japan.
 □ : Non stock, produced to order only.
 ◇ : Special Tool, produced to order only

Step Type

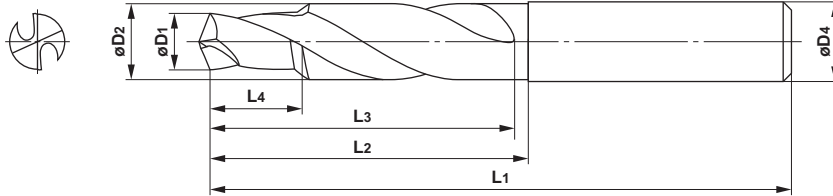

Dimensions

Drill Dia. D1 (mm)	Stock		Dimensions (mm)					
	VP15TF		D2	L4	L3	L1	L2	D4
10	◇		16	15	50	100	50	16
11	◇		17	20	55	110	55	17
12	◇		18	20	55	110	55	18
13	◇		18	20	55	110	55	18
14	◇		18	20	55	110	55	18

Chamfer Diameter Reference Range

■ : Applicable Range

Max. Chamfer Cutting Edge Dia. (mm)	Drill Dia. D1 (mm)	Chamfer Cutting Edge Dia. D2 (mm)									
		10	11	12	13	14	15	16	17	18	
16	10		■	■	■	■	■	■			
17.6	11			■	■	■	■	■	■		
19.2	12				■	■	■	■	■	■	
20	13					■	■	■	■	■	
20	14						■	■	■	■	
20	15							■	■	■	
20	16								■	■	
20	17									■	

Step Length Range

■ : Applicable Range

Drill Dia. D1 (mm)	Step Length L4 (mm)				
	10	15	20	25	30
10	■	■			
11	■	■			
12	■	■			
13	■	■	■		
14	■	■	■		
15	■	■	■		
16	■	■	■	■	
17	■	■	■	■	

Flute Length Range

■ : Applicable Range

Drill Dia. D1 (mm)	Flute Length L3 (mm)				
	45	50	55	60	65
10	■	■			
11	■	■	■		
12	■	■	■		
13	■	■	■		
14	■	■	■		
15	■	■	■		
16	■	■	■	■	
17	■	■	■	■	

Product Range

Drill dia. **D1**: $\phi 10\text{--}\phi 18\text{mm}$

Chamfer dia. **D2**: $D2/D1 \leq 1.6$ and up to $\phi 18\text{mm}$

Overall length **L1**: To be determined based on the straight type drill.

If the chamfer diameter is $\phi 16\text{mm}$, the maximum overall length is 112mm.

Shank dia. **D4**: Same as the chamfer diameter up to $\phi 16$.

Increases in 0.5mm increments for the diameter larger than $\phi 16$.

Tool grade : VP15TF

Notes When Regrinding and Recoating the Drill

- When carrying out regrinding, it is necessary to recoat the drill to maintain tool life.
- When requesting regrinding and recoating of the drill, contact Mitsubishi Materials sales staff.

Cutting Performance

Hole Accuracy (no reaming needed)

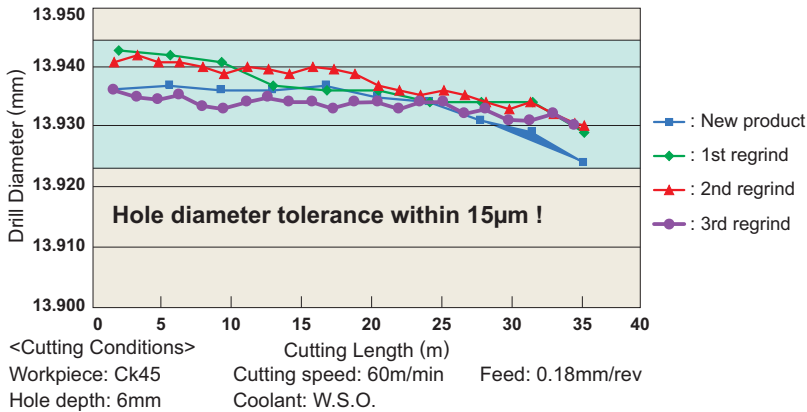

Chip Geometry



Chip breaking properties
 The workpiece surface is not damaged due to the fine chips that were generated.

Result of Reducing the Cutting Torque

Prevents the generation of high cutting temperatures and the formation of a work hardened layer.

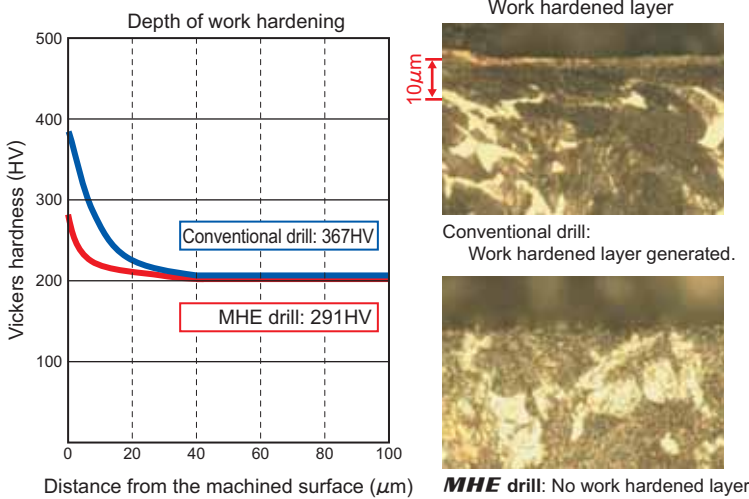

Tough Drill Tool Grade

● Long tool life

MIRACLE® coated

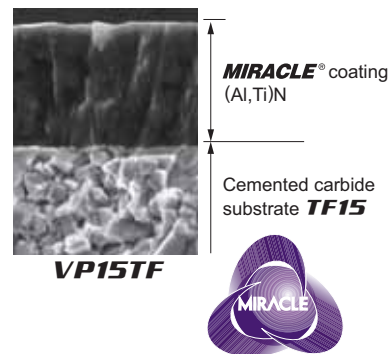

MIRACLE® coated **VP15TF** has a high welding resistance, making it suitable for machining a wide range of workpiece materials from mild steels and carbon steels, through to stainless steels and cast iron.

The **MHE** drill can prevent the formation of a work hardened layer (that usually causes tool damage), and makes it possible to produce high quality holes.

Override Comparison

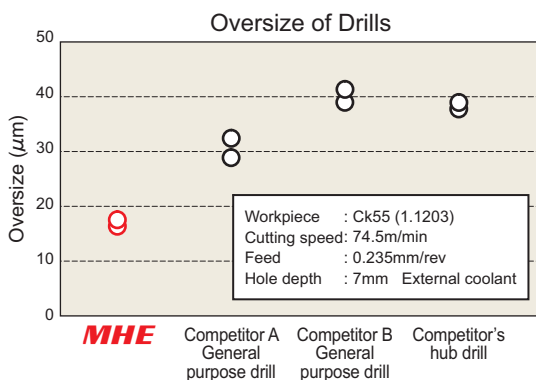



Recommended Cutting Conditions

Work Material	Hardness	φ10.0—φ18.0	
		Cutting Speed (m/min)	Feed (mm/rev)
P Carbon Steel	180—280HB	75 (60—90)	0.25 (0.15—0.30)

(Note) The above cutting conditions should be used as a guide and need to be adjusted according to the machine rigidity, workpiece clamping and shape.

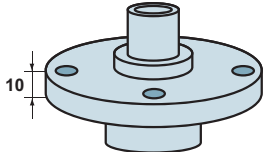
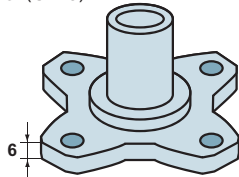
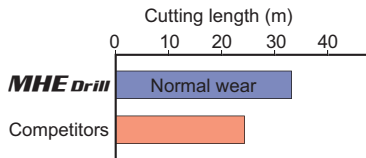
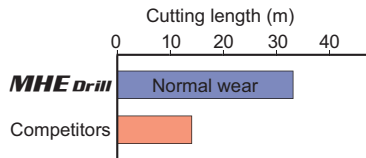
Application Examples

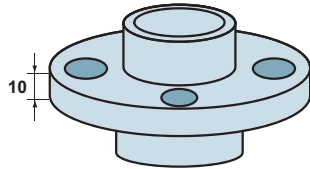
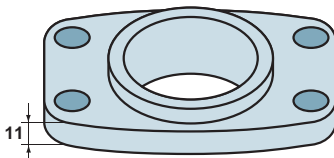
Tool		MHE 13.93 x 104 x 14	MHE 13.93 x 104 x 14
Workpiece		Carbon Steel (Ck45) 	Carbon Steel (Ck45) 
Component		Inner face of hub	Inner face of hub
Cutting Conditions	Cutting Speed (m/min)	92	83
	Feed (mm/rev)	0.3	0.2
	Revolution (min ⁻¹)	2100	1900
Coolant		W.S.O.	W.S.O.
Machine Type		Machining centre	Machining centre
Results			

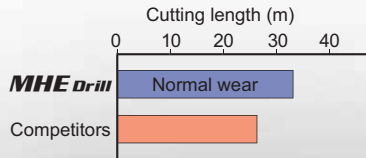
Tool		MHE 16.10 x 110 x 16.1	MHE 10.8 x 93 x 10.8
Workpiece		Carbon Steel (Ck45) 	Carbon Steel (Ck45) 
Component		Inner face of hub	Outer face of hub
Cutting Conditions	Cutting Speed (m/min)	68	68
	Feed (mm/rev)	0.2	0.2
	Revolution (min ⁻¹)	1350	2000
Coolant		W.S.O.	W.S.O.
Machine Type		Machining centre	Machining centre
Results			



STAW

Small diameter indexable drill for a wide application area. Innovative insert clamping offers stability when drilling small holes.

PRECISION
FOR SUCCESS

CHOOSE JAPAN'S NO. 1

mitsubishi
MITSUBISHI MATERIALS

www.mitsubishicarbide.com

Small Diameter Indexable Drill

S-TAW

Features

Designed for extreme sharpness, precision and rigidity

Wavy cutting edge

The wave edge design achieves a sharp peripheral edge cutting performance with a strong centre point for initial cutting.

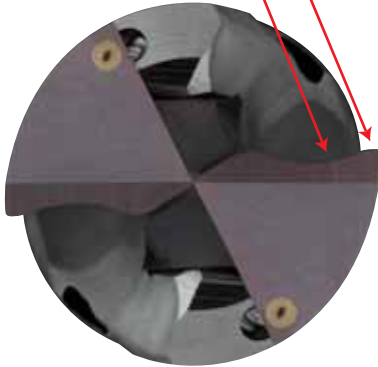

High helix

Unique low resistance pocket design improves chip breaking for superior chip disposal.

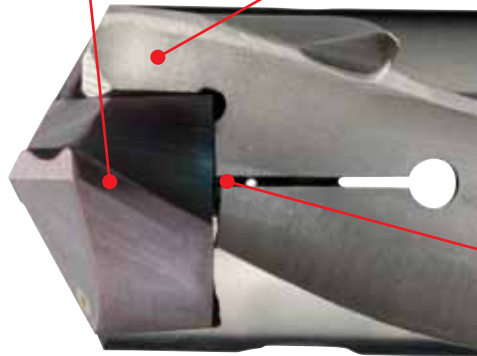

Back metal

Sufficient back metal increases rigidity.

Centering location

Mitsubishi's unique system ensures high clamping accuracy.

Mitsubishi's unique highly rigid clamping system (PAT.P.)

Back metal (with taper)

Fixed stopper

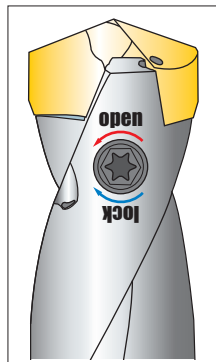
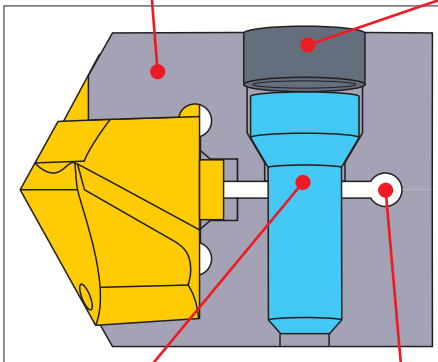

Inner screw

Slit

<Clamp>

Tighten the inner screw to securely clamp the insert with the back metal tapers.

<Unclamp>

Loosening the screw causes it to push against the stopper and opens the back metal sections.

<Insert installation and detachment>

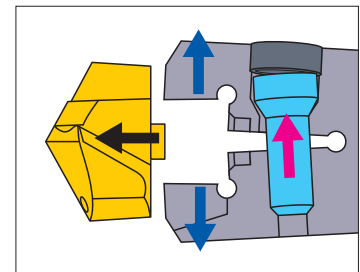
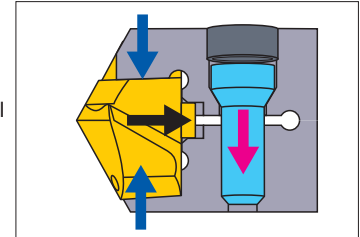

MIRACLE® coated VP15TF

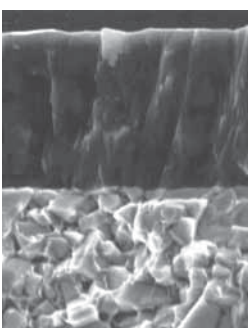

MIRACLE®
coating
(Al,Ti)N

Cemented
carbide
substrate
TF15

VP15TF



Features of VP15TF

MIRACLE® coated VP15TF has a high welding resistance, making it suitable for machining a wide range of workpiece materials from mild steels and carbon steels, through to stainless steels and cast iron.

DRILLING (INDEXABLE TYPE)

S-TAW

- Small diameter indexable drill
- Miracle coated inserts for high performance
- All drills with through coolant holes as standard.



P	M	K	S	N	H
✓		✓			

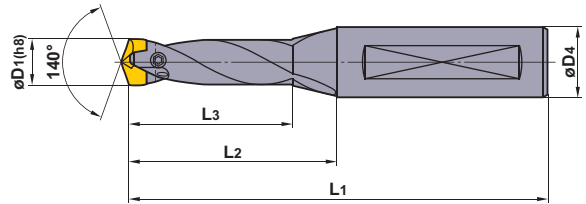

S-TAW DRILLS



Ø10.0 ~ 13.9

Drill Dia. Range D1 (mm)	Hole Depth (l/d)	Holder		Insert		Dimensions (mm)				Wrench	
		Order Number	Stock	Drill Dia. D1 (mm)	Order Number	Stock	L3	L2	L1		D4
10.0 10.4	3	STAWSN1000S16	●	10.0	STAWN1000TH	●	37	47	95	16	①TIP06F
				10.1	STAWN1010TH	●					
				10.2	STAWN1020TH	●					
	5	STAWMN1000S16	●	10.3	STAWN1030TH	●	57	67	115	16	①TIP06F
				10.4	STAWN1040TH	●					
10.5 10.9	3	STAWSN1050S16	●	10.5	STAWN1050TH	●	37	47	95	16	①TIP06F
				10.6	STAWN1060TH	●					
				10.7	STAWN1070TH	●					
	5	STAWMN1050S16	●	10.8	STAWN1080TH	●	57	67	115	16	①TIP06F
				10.9	STAWN1090TH	●					
11.0 11.4	3	STAWSN1100S16	●	11.0	STAWN1100TH	●	41	52	100	16	①TIP06F
				11.1	STAWN1110TH	●					
				11.2	STAWN1120TH	●					
	5	STAWMN1100S16	●	11.3	STAWN1130TH	●	66	77	125	16	①TIP06F
				11.4	STAWN1140TH	●					
11.5 11.9	3	STAWSN1150S16	●	11.5	STAWN1150TH	●	41	52	100	16	①TIP06F
				11.6	STAWN1160TH	●					
				11.7	STAWN1170TH	●					
	5	STAWMN1150S16	●	11.8	STAWN1180TH	●	66	77	125	16	①TIP06F
				11.9	STAWN1190TH	●					
12.0 12.4	3	STAWSN1200S16	●	12.0	STAWN1200TH	●	45	57	105	16	①TIP06F
				12.1	STAWN1210TH	●					
				12.2	STAWN1220TH	●					
	5	STAWMN1200S16	●	12.3	STAWN1230TH	●	70	82	130	16	①TIP06F
				12.4	STAWN1240TH	●					
12.5 12.9	3	STAWSN1250S16	●	12.5	STAWN1250TH	●	45	57	105	16	①TIP06F
				12.6	STAWN1260TH	●					
				12.7	STAWN1270TH	●					
	5	STAWMN1250S16	●	12.8	STAWN1280TH	●	70	82	130	16	①TIP06F
				12.9	STAWN1290TH	●					
13.0 13.4	3	STAWSN1300S16	●	13.0	STAWN1300TH	●	49	62	110	16	②TIP08W
				13.1	STAWN1310TH	●					
				13.2	STAWN1320TH	●					
	5	STAWMN1300S16	●	13.3	STAWN1330TH	●	74	87	135	16	②TIP08W
				13.4	STAWN1340TH	●					
13.5 13.9	3	STAWSN1350S16	●	13.5	STAWN1350TH	●	49	62	110	16	②TIP08W
				13.6	STAWN1360TH	●					
				13.7	STAWN1370TH	●					
	5	STAWMN1350S16	●	13.8	STAWN1380TH	●	74	87	135	16	②TIP08W
				13.9	STAWN1390TH	●					

(Note) Please contact us for any geometry that is not in this catalogue (e.g. different diameter and length).

- : Stock Standard
- ★ : Stock Standard in Japan.
- : Non stock, produced to order only

Inserts

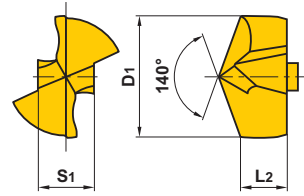

Order Number	Stock		Dimensions (mm)			Applicable Holder
	VP15TF		D1	L2	S1	
STAWN1000TH	●		10.0	3.8	4.6	STAWSN1000S16 STAWMN1000S16
1010TH	●		10.1	3.8	4.6	
1020TH	●		10.2	3.8	4.6	
1030TH	●		10.3	3.8	4.6	
1040TH	●		10.4	3.8	4.6	
1050TH	●		10.5	4.0	4.8	STAWSN1050S16 STAWMN1050S16
1060TH	●		10.6	4.0	4.8	
1070TH	●		10.7	4.0	4.8	
1080TH	●		10.8	4.0	4.8	
1090TH	●		10.9	4.0	4.8	
1100TH	●		11.0	4.2	5.1	STAWSN1100S16 STAWMN1100S16
1110TH	●		11.1	4.2	5.1	
1120TH	●		11.2	4.2	5.1	
1130TH	●		11.3	4.2	5.1	
1140TH	●		11.4	4.2	5.1	
1150TH	●		11.5	4.4	5.3	STAWSN1150S16 STAWMN1150S16
1160TH	●		11.6	4.4	5.3	
1170TH	●		11.7	4.4	5.3	
1180TH	●		11.8	4.4	5.3	
1190TH	●		11.9	4.4	5.3	
1200TH	●		12.0	4.6	5.5	STAWSN1200S16 STAWMN1200S16
1210TH	●		12.1	4.6	5.5	
1220TH	●		12.2	4.6	5.5	
1230TH	●		12.3	4.6	5.5	
1240TH	●		12.4	4.6	5.5	
1250TH	●		12.5	4.8	5.8	STAWSN1250S16 STAWMN1250S16
1260TH	●		12.6	4.8	5.8	
1270TH	●		12.7	4.8	5.8	
1280TH	●		12.8	4.8	5.8	
1290TH	●		12.9	4.8	5.8	
1300TH	●		13.0	4.9	6.0	STAWSN1300S16 STAWMN1300S16
1310TH	●		13.1	4.9	6.0	
1320TH	●		13.2	4.9	6.0	
1330TH	●		13.3	4.9	6.0	
1340TH	●		13.4	4.9	6.0	
1350TH	●		13.5	5.1	6.2	STAWSN1350S16 STAWMN1350S16
1360TH	●		13.6	5.1	6.2	
1370TH	●		13.7	5.1	6.2	
1380TH	●		13.8	5.1	6.2	
1390TH	●		13.9	5.1	6.2	

S-TAW DRILLS



Ø 10.0~
13.9

CUTTING CONDITIONS



D149

Recommended Cutting Conditions

Work Material	Drill Diameter Conditions Hardness	$\phi 10.0-\phi 12.9$		$\phi 13.0-\phi 13.9$	
		Cutting Speed (m/min)	Feed (mm/rev)	Cutting Speed (m/min)	Feed (mm/rev)
P Mild Steel	$\leq 180\text{HB}$	80 (60-100)	0.20 (0.15-0.25)	90 (70-110)	0.25 (0.20-0.30)
	180-280HB	80 (60-100)	0.20 (0.15-0.25)	90 (70-110)	0.25 (0.20-0.30)
	280-350HB	70 (60-90)	0.20 (0.15-0.25)	80 (60-100)	0.25 (0.20-0.30)
M Stainless Steel	$\leq 200\text{HB}$	40 (30-50)	0.13 (0.10-0.16)	50 (40-60)	0.15 (0.12-0.18)
K Cast Iron	Tensile Strength $\leq 350\text{MPa}$	80 (60-100)	0.20 (0.15-0.25)	90 (70-110)	0.25 (0.20-0.30)
	Tensile Strength $\leq 450\text{MPa}$	70 (60-90)	0.20 (0.15-0.25)	80 (60-100)	0.25 (0.20-0.30)

Operational Guidance

Insert Installation

1. Before inserting the insert into the holder, ensure that there are no foreign objects or dirt in the holder slot or slit. Clean using compressed air if necessary.

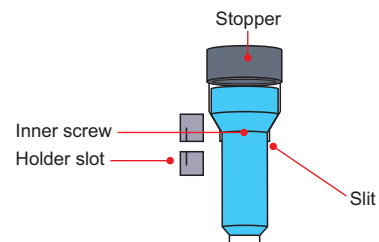

2. Use the wrench provided to loosen the inner screw to open the tip of the holder, then place the insert into the holder slot as shown in figure 1.
* Ensure that the wrench is firmly in contact with the base of the inner screw head when tightening.

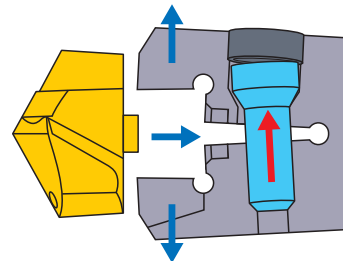
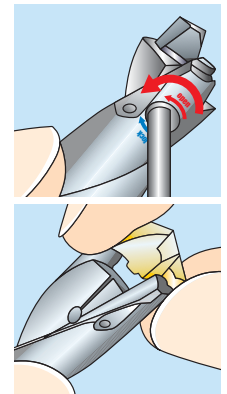

Fig. 1



3. After the insert has been set in the holder slot, tighten the inner screw while pushing the insert lightly into the pocket as shown in figure 2 to securely clamp and locate the insert.

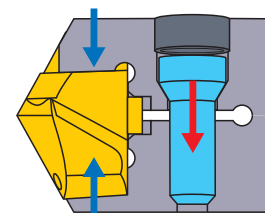
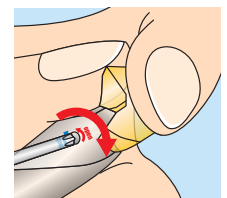
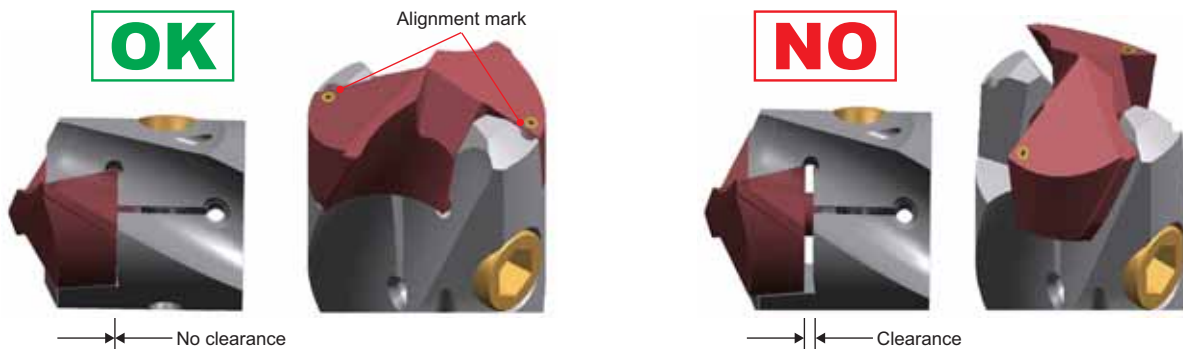

Fig. 2



* Ensure that the wrench is firmly in contact with the base of the inner screw head when tightening.

4. Check there is no gap between the bottom of the insert and holder slot.



Note) Poor or incorrect clamping of inserts can cause poor drilling performance and/or drill breakage. Therefore ensure that the alignment marks on both the body and insert are aligned when setting. When machining, use safety guards and goggles.



TAW

**Indexable drill for a wide application area.
Innovative insert clamping offers high stability.**



PRECISION
FOR SUCCESS

CHOOSE JAPAN'S NO. 1

MITSUBISHI
MITSUBISHI MATERIALS

www.mitsubishicarbide.com

Features

Designed for extreme sharpness and accuracy

Wave type cutting edge for superior chip control

The wave edge design achieves sharp peripheral edge cutting performance with a strong initial cutting point near the centre.

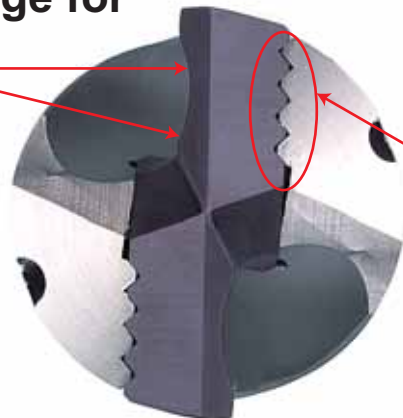

Cutting edge shape

Serrated insert clamping geometry

Mitsubishi's unique serration structure allows high clamping accuracy to be maintained.

TAW DRILLS
DRILLING

Inserts

New through hole clamping type for added reliability and long tool life

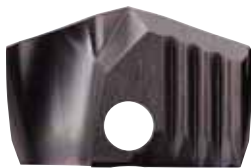

Exceptional tool life

MIRACLE coated VP15TF delivering exceptional tool life.

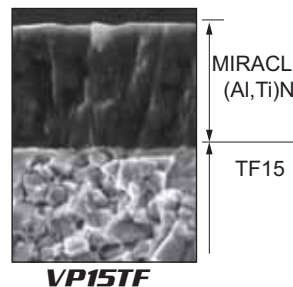

Features of VP15TF

MIRACLE coated VP15TF is ideal for drilling due to its' high resistance to chip welding. Suitable for machining a wide range of workpiece materials from Mild and Alloy steels through to Stainless steels and Cast iron.

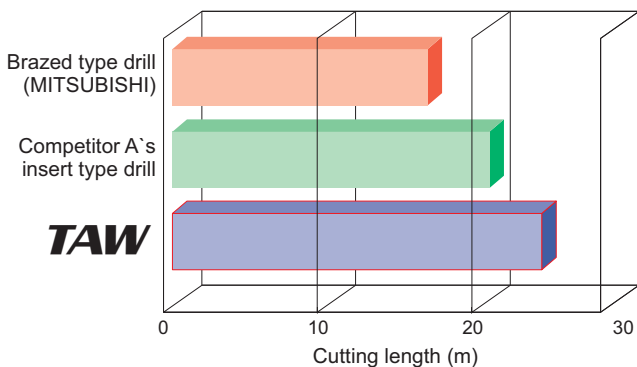

High durability body

The cutter bodies are made resistant to corrosion and abrasion by using a superior, high heat resistant alloy and a special surface treatment.



<Cutting conditions>

Workpiece : DIN C50 (150-180HB)
 Drill diameter : ø20 (L/D=5)
 Cutting speed: 100m/min
 Feed : 0.25mm/rev

Coolant : Emulsion 10%
 Pressure : 0.5MPa
 (Internal coolant)

Cutting performance

Over Size

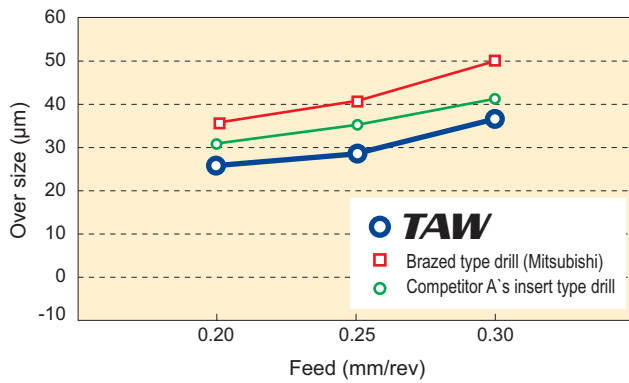

<Cutting conditions>
 Workpiece : DIN C50(150 - 180HB)
 Drill diameter : $\phi 20$ (L/D=5)
 Cutting speed : 80m/min
 Coolant : Emulsion 10%
 Pressure : 0.5MPa(Internal coolant)

Surface Roughness

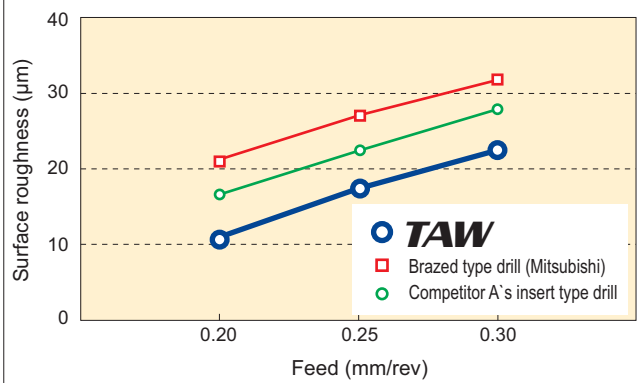

<Cutting conditions>
 Workpiece : DIN C50(150 - 180HB)
 Drill diameter : $\phi 20$ (L/D=5)
 Cutting speed : 80m/min
 Coolant : Emulsion 10%
 Pressure : 0.5MPa(Internal coolant)

Insert Life

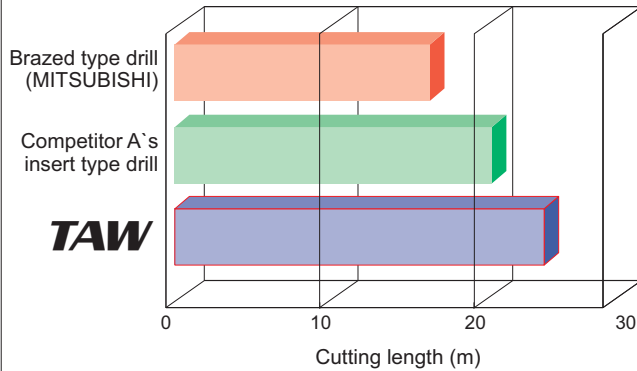

<Cutting conditions>
 Workpiece : DIN C50(150 - 180HB) Coolant : Emulsion 10%
 Drill diameter : $\phi 20$ (L/D=5) Pressure : 0.5MPa(Internal coolant)
 Cutting speed: 100m/min
 Feed : 0.25mm/rev

Power Consumption

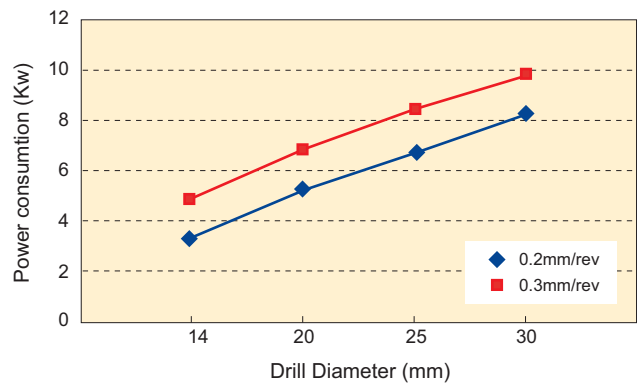

<Cutting conditions>
 Workpiece : DIN C50 (150 - 180HB)
 Cutting speed : 80m/min
 Coolant : Emulsion 10%
 Pressure : 0.5MPa(Internal coolant)

DRILLING (INDEXABLE TYPE)

TAW

- Wavy cutting edge design for good chip control.
- Serration geometry for accurate insert location.
- Easy insert exchange.



P	M	K	S	N	H
✓		✓			

D1(h7)	10.0 < D1 ≤ 18.0	18.0 < D1 ≤ 30.0
Tolerance	0 -0.018	0 -0.021

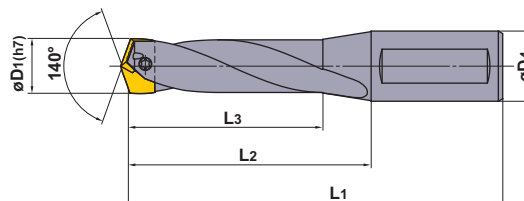





TAW DRILLS

Drill Dia. Range D1 (mm)	Hole Depth (l/d)	Holder		Insert		Dimensions (mm)				Clamp Screw	Wrench	Plate	Anti-seize Lubricant		
		Order Number	Stock	Drill Dia. D1 (mm)	Order Number	Stock	L3	L2	L1					D4	
14.0 14.4	3	TAWSNH1400S16	●	14.0	TAWNH1400T	●	□	51	67	115	16	WS254012T	TKY08D	WPT4405	MK1KS
				14.1	TAWNH1410T	●	□								
	5 <small>NEW</small>	TAWMNH1400S16	●	14.2	TAWNH1420T	●	□	80	97	145	16	WS254012T	TKY08D	WPT4405	MK1KS
				14.3	TAWNH1430T	●	□								
8	TAWLNH1400S16	●	14.4	TAWNH1440T	●	□	122	137	185	16	WS254012T	TKY08D	WPT4405	MK1KS	
			14.5	TAWNH1450T	●	□									
14.5 15.4	3	TAWSNH1500S20	●	14.5	TAWNH1450T	●	□	54	75	125	20	WS254013T	TKY08D	WPT4405	MK1KS
				14.6	TAWNH1460T	●	□								
				14.7	TAWNH1470T	●	□								
				14.8	TAWNH1480T	●	□								
	5	TAWMNH1500S20	●	14.9	TAWNH1490T	●	□	85	105	155	20	WS254013T	TKY08D	WPT4405	MK1KS
				15.0	TAWNH1500T	●	□								
				15.1	TAWNH1510T	●	□								
				15.2	TAWNH1520T	●	□								
8 <small>NEW</small>	TAWLNH1500S20	●	15.3	TAWNH1530T	●	□	130	148	198	20	WS254013T	TKY08D	WPT4405	MK1KS	
			15.4	TAWNH1540T	●	□									
15.5 16.4	3	TAWSN1600S20	●	15.5	TAWNH1550T	●	□	58	80	130	20	WS254014T	TKY08D	WPT4405	MK1KS
				15.6	TAWNH1560T	●	□								
				15.7	TAWNH1570T	●	□								
	5	TAWMN1600S20	●	15.8	TAWNH1580T	●	□	91	115	165	20	WS254014T	TKY08D	WPT4405	MK1KS
				15.9	TAWNH1590T	●	□								
				16.0	TAWNH1600T	●	□								
				16.1	TAWNH1610T	●	□								
	8 <small>NEW</small>	TAWLN1600S20	●	16.2	TAWNH1620T	●	□	138	158	208	20	WS254014T	TKY08D	WPT4405	MK1KS
16.3				TAWNH1630T	●	□									
16.4				TAWNH1640T	●	□									

(Note 1) Please contact us for any geometry that is not in this catalogue (e.g. different diameter and length).

- : Stock Standard
- ★ : Stock Standard in Japan.
- : Non stock, produced to order only

Drill Dia. Range D1 (mm)	Hole Depth (l/d)	Holder		Insert				Dimensions (mm)							
		Order Number	Stock	Drill Dia. D1 (mm)	Order Number	Stock		L3	L2	L1	D4				
						VP15TF	VP10H								
16.5 17.4	3	TAWSN1700S20	●	16.5	TAWNH1650T	●	<input type="checkbox"/>	61	85	135	20	WS254015T	①TKY08D	WPT4405	MK1KS
				16.6	TAWNH1660T	●	<input type="checkbox"/>								
				16.7	TAWNH1670T	●	<input type="checkbox"/>								
	5	TAWMN1700S20	●	16.8	TAWNH1680T	●	<input type="checkbox"/>	96	120	170	20	WS254015T	①TKY08D	WPT4405	MK1KS
				16.9	TAWNH1690T	●	<input type="checkbox"/>								
				17.0	TAWNH1700T	●	<input type="checkbox"/>								
				17.1	TAWNH1710T	●	<input type="checkbox"/>								
	NEW 8	TAWLN1700S20	●	17.2	TAWNH1720T	●	<input type="checkbox"/>	146	166	216	20	WS254015T	①TKY08D	WPT4405	MK1KS
				17.3	TAWN1730TH	●	<input type="checkbox"/>								
17.4				TAWNH1740T	●	<input type="checkbox"/>									
17.5 18.4	3	TAWSN1800S20	●	17.5	TAWNH1750T	●	<input type="checkbox"/>	65	90	140	20	WS254016T	①TKY08D	WPT4405	MK1KS
				17.6	TAWNH1760T	●	<input type="checkbox"/>								
				17.7	TAWNH1770T	●	<input type="checkbox"/>								
	5	TAWMN1800S20	●	17.8	TAWNH1780T	●	<input type="checkbox"/>	102	125	175	20	WS254016T	①TKY08D	WPT4405	MK1KS
				17.9	TAWNH1790T	●	<input type="checkbox"/>								
				18.0	TAWNH1800T	●	<input type="checkbox"/>								
				18.1	TAWNH1810T	●	<input type="checkbox"/>								
	NEW 8	TAWLN1800S20	●	18.2	TAWNH1820T	●	<input type="checkbox"/>	154	174	224	20	WS254016T	①TKY08D	WPT4405	MK1KS
				18.3	TAWNH1830T	●	<input type="checkbox"/>								
18.4				TAWNH1840T	●	<input type="checkbox"/>									
18.5 19.4	3	TAWSN1900S25	●	18.5	TAWNH1850T	●	<input type="checkbox"/>	68	99	155	25	WS304517T	②TKY10T	WPT4405	MK1KS
				18.6	TAWNH1860T	●	<input type="checkbox"/>								
				18.7	TAWNH1870T	●	<input type="checkbox"/>								
	5	TAWMN1900S25	●	18.8	TAWNH1880T	●	<input type="checkbox"/>	107	134	190	25	WS304517T	②TKY10T	WPT4405	MK1KS
				18.9	TAWNH1890T	●	<input type="checkbox"/>								
				19.0	TAWNH1900T	●	<input type="checkbox"/>								
				19.1	TAWNH1910T	●	<input type="checkbox"/>								
	NEW 8	TAWLN1900S25	●	19.2	TAWNH1920T	●	<input type="checkbox"/>	162	185	241	25	WS304517T	②TKY10T	WPT4405	MK1KS
				19.3	TAWNH1930T	●	<input type="checkbox"/>								
19.4				TAWNH1940T	●	<input type="checkbox"/>									

TAW DRILLS



Ø 16.5~19.4

CUTTING CONDITIONS



D162

D155

DRILLING (INDEXABLE TYPE)

TAW

- Wavy cutting edge design for good chip control.
- Serration geometry for accurate insert location.
- Easy insert exchange.



P	M	K	S	N	H
✓		✓			



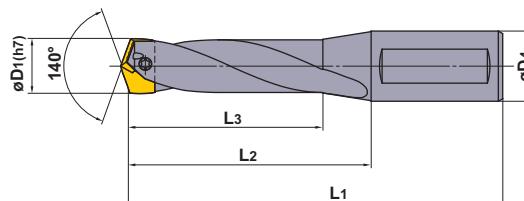

D1(h7)	10.0 < D1 ≤ 18.0	18.0 < D1 ≤ 30.0
Tolerance	0 -0.018	0 -0.021



Drill Dia. Range D1 (mm)	Hole Depth (l/d)	Holder		Insert				Dimensions (mm)				 Clamp Screw	 Wrench	 Plate	 Anti-seize Lubricant
		Order Number	Stock	Drill Dia. D1 (mm)	Order Number	Stock		L3	L2	L1	D4				
						VP15TF	VP10H								
19.5 20.4	3	TAWSN2000S25	●	19.5	TAWNH1950T	●	□	72	99	155	25	WS304518T	TKY10T	WPT4405	MK1KS
				19.6	TAWNH1960T	●	□								
				19.7	TAWNH1970T	●	□								
	5	TAWMN2000S25	●	19.8	TAWNH1980T	●	□	113	139	195	25	WS304518T	TKY10T	WPT4405	MK1KS
				19.9	TAWNH1990T	●	□								
				20.0	TAWNH2000T	●	□								
				20.1	TAWNH2010T	□	□								
	8	TAWLN2000S25	●	20.2	TAWNH2020T	□	□	170	193	249	25	WS304518T	TKY10T	WPT4405	MK1KS
				20.3	TAWNH2030T	□	□								
20.4				TAWNH2040T	□	□									
20.5 21.4	3	TAWSN2100S25	●	20.5	TAWNH2050T	●	□	75	99	155	25	WS304518T	TKY10T	WPT4405	MK1KS
				20.6	TAWNH2060T	□	□								
				20.7	TAWNH2070T	□	□								
	5	TAWMN2100S25	●	20.8	TAWNH2080T	□	□	118	139	195	25	WS304518T	TKY10T	WPT4405	MK1KS
				20.9	TAWNH2090T	□	□								
				21.0	TAWNH2100T	●	□								
				21.1	TAWNH2110T	□	□								
	8	TAWLN2100S25	●	21.2	TAWNH2120T	□	□	178	202	258	25	WS304518T	TKY10T	WPT4405	MK1KS
				21.3	TAWNH2130T	□	□								
21.4				TAWNH2140T	□	□									
21.5 22.4	3	TAWSN2200S25	●	21.5	TAWNH2150T	●	□	79.3	104.3	160.3	25	WS355520T	TKY15T	WPT4405	MK1KS
				21.6	TAWNH2160T	□	□								
	5	TAWMN2200S25	●	21.7	TAWNH2170T	□	□	124.3	144.3	200.3	25	WS355520T	TKY15T	WPT4405	MK1KS
				21.8	TAWNH2180T	□	□								
				21.9	TAWNH2190T	□	□								
8	TAWLN2200S25	●	21.9	TAWNH2190T	□	□	186	210	266	25	WS355520T	TKY15T	WPT4405	MK1KS	

(Note 1) Please contact us for any geometry that is not in this catalogue (e.g. different diameter and length).

- : Stock Standard
- ★ : Stock Standard in Japan.
- : Non stock, produced to order only

Drill Dia. Range D1 (mm)	Hole Depth (l/d)	Holder		Insert				Dimensions (mm)							
		Order Number	Stock	Drill Dia. D1 (mm)	Order Number	Stock		L3	L2	L1	D4				
						VP15TF	VP10H								
21.5 22.4	3	TAWSN2200S25	●	22.0	TAWNH2200T	●	□	79.3	104.3	160.3	25	WS355520T	TKY15T	WPT4405	MK1KS
				22.1	TAWNH2210T	□	□								
		5	TAWMN2200S25	●	22.2	TAWNH2220T	□	□	124.3	144.3	200.3	25	WS355520T	TKY15T	WPT4405
	22.3				TAWNH2230T	□	□								
	8		TAWLN2200S25	●	22.4	TAWNH2240T	□	□	186	210	266	25	WS355520T	TKY15T	WPT4405
	22.5 23.4	3	TAWSN2300S25	●	22.5	TAWNH2250T	●	□	82.3	104.3	160.3	25	WS355521T	TKY15T	WPT4405
22.6					TAWNH2260T	□	□								
22.7					TAWNH2270T	□	□								
5		TAWMN2300S25	●	22.8	TAWNH2280T	□	□	129.3	154.3	210.3	25	WS355521T	TKY15T	WPT4405	MK1KS
				22.9	TAWNH2290T	□	□								
				23.0	TAWNH2300T	●	□								
				23.1	TAWNH2310T	□	□								
8		TAWLN2300S25	●	23.2	TAWNH2320T	□	□	194	223	279	25	WS355521T	TKY15T	WPT4405	MK1KS
				23.3	TAWNH2330T	□	□								
				23.4	TAWNH2340T	□	□								
23.5 24.4	3	TAWSN2400S32	●	23.5	TAWNH2350T	●	□	86.3	110.3	170.3	32	WS355521T	TKY15T	WPT4405	MK1KS
				23.6	TAWNH2360T	□	□								
				23.7	TAWNH2370T	□	□								
	5	TAWMN2400S32	●	23.8	TAWNH2380T	□	□	135.3	160.3	220.3	32	WS355521T	TKY15T	WPT4405	MK1KS
				23.9	TAWNH2390T	□	□								
				24.0	TAWNH2400T	●	□								
				24.1	TAWNH2410T	□	□								
	8	TAWLN2400S32	●	24.2	TAWNH2420T	□	□	202	232	292	32	WS355521T	TKY15T	WPT4405	MK1KS
				24.3	TAWNH2430T	□	□								
				24.4	TAWNH2440T	□	□								
24.5 25.4	3	TAWSN2500S32	●	24.5	TAWNH2450T	●	□	88.6	110.6	170.6	32	WS406023T	TKY25T	WPT4405	MK1KS
				24.6	TAWNH2460T	□	□								
	5	TAWMN2500S32	●	24.7	TAWNH2470T	□	□	140.6	165.6	225.6	32	WS406023T	TKY25T	WPT4405	MK1KS
				24.8	TAWNH2480T	□	□								
				8	TAWLN2500S32	●	24.9								

TAW DRILLS



Ø 22.0~24.9

CUTTING CONDITIONS



D162

DRILLING (INDEXABLE TYPE)

TAW

- Wavy cutting edge design for good chip control.
- Serration geometry for accurate insert location.
- Easy insert exchange.



P	M	K	S	N	H
✓		✓			



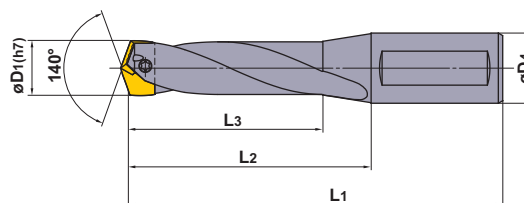

D1(h7)	10.0 < D1 ≤ 18.0	18.0 < D1 ≤ 30.0
Tolerance	0 -0.018	0 -0.021



Drill Dia. Range D1 (mm)	Hole Depth (l/d)	Holder		Insert			Dimensions (mm)				Clamp Screw	Wrench	Plate	Anti-seize Lubricant	
		Order Number	Stock	Drill Dia. D1 (mm)	Order Number	Stock		L3	L2	L1					D4
						VP15TF	VP10H								
24.5 25.4	3	TAWSN2500S32	●	25.0	TAWNH2500T	●	□	88.6	110.6	170.6	32	WS406023T	TKY25T	WPT4405	MK1KS
				25.1	TAWNH2510T	□	□								
	5	TAWMN2500S32	●	25.2	TAWNH2520T	□	□	140.6	165.6	225.6	32	WS406023T	TKY25T	WPT4405	MK1KS
				25.3	TAWNH2530T	□	□								
8	TAWLN2500S32	●	25.4	TAWNH2540T	□	□	210	240	300	32	WS406023T	TKY25T	WPT4405	MK1KS	
			25.5	TAWNH2550T	●	□									
25.5 26.4	3	TAWSN2600S32	●	25.6	TAWNH2560T	□	□	92.6	115.6	175.6	32	WS406024T	TKY25T	WPT4405	MK1KS
				25.7	TAWNH2570T	□	□								
				25.8	TAWNH2580T	□	□								
	5	TAWMN2600S32	●	25.9	TAWNH2590T	□	□	146.6	170.6	230.6	32	WS406024T	TKY25T	WPT4405	MK1KS
				26.0	TAWNH2600T	●	□								
				26.1	TAWNH2610T	□	□								
	8	TAWLN2600S32	●	26.2	TAWNH2620T	□	□	218	248	308	32	WS406024T	TKY25T	WPT4405	MK1KS
				26.3	TAWNH2630T	□	□								
26.4				TAWNH2640T	□	□									
26.5				TAWNH2650T	●	□									
26.5 27.4	3	TAWSN2700S32	●	26.6	TAWNH2660T	□	□	94.6	115.6	175.6	32	WS406024T	TKY25T	WPT4405	MK1KS
				26.7	TAWNH2670T	□	□								
				26.8	TAWNH2680T	□	□								
	5	TAWMN2700S32	●	26.9	TAWNH2690T	□	□	151.6	175.6	235.6	32	WS406024T	TKY25T	WPT4405	MK1KS
				27.0	TAWNH2700T	●	□								
				27.1	TAWNH2710T	□	□								
	8	TAWLN2700S32	●	27.2	TAWNH2720T	□	□	226	256	316	32	WS406024T	TKY25T	WPT4405	MK1KS
				27.3	TAWNH2730T	□	□								
27.4				TAWNH2740T	□	□									
27.5				TAWNH2750T	●	□									

(Note 1) Please contact us for any geometry that is not in this catalogue (e.g. different diameter and length).

- : Stock Standard
- ★ : Stock Standard in Japan.
- : Non stock, produced to order only

Drill Dia. Range D1 (mm)	Hole Depth (l/d)	Holder		Insert				Dimensions (mm)							
		Order Number	Stock	Drill Dia. D1 (mm)	Order Number	Stock		L3	L2	L1	D4				
						VP15TF	VP10H								
27.5 28.4	3	TAWSN2800S32	●	27.5	TAWNH2750T	●	□	97.2	120.2	180.2	32	WS508026T	TKY27T	WPT4405	MK1KS
				27.6	TAWNH2760T	□	□								
				27.7	TAWNH2770T	□	□								
	5	TAWMN2800S32	●	27.8	TAWNH2780T	□	□	157.2	180.2	240.2	32	WS508026T	TKY27T	WPT4405	MK1KS
				27.9	TAWNH2790T	□	□								
				28.0	TAWNH2800T	●	□								
				28.1	TAWNH2810T	□	□								
				28.2	TAWNH2820T	□	□								
				28.3	TAWNH2830T	□	□								
	8 <small>NEW</small>	TAWLN2800S32	●	28.2	TAWNH2820T	□	□	234	264	324	32	WS508026T	TKY27T	WPT4405	MK1KS
				28.3	TAWNH2830T	□	□								
				28.4	TAWNH2840T	□	□								
28.5 29.4	3	TAWSN2900S32	●	28.5	TAWNH2850T	●	□	100.2	125.2	185.2	32	WS508027T	TKY27T	WPT4405	MK1KS
				28.6	TAWNH2860T	□	□								
				28.7	TAWNH2870T	□	□								
	5	TAWMN2900S32	●	28.8	TAWNH2880T	□	□	162.2	185.2	245.2	32	WS508027T	TKY27T	WPT4405	MK1KS
				28.9	TAWNH2890T	□	□								
				29.0	TAWNH2900T	●	□								
				29.1	TAWNH2910T	□	□								
				29.2	TAWNH2920T	□	□								
				29.3	TAWNH2930T	□	□								
	8 <small>NEW</small>	TAWLN2900S32	●	29.2	TAWNH2920T	□	□	242	272	332	32	WS508027T	TKY27T	WPT4405	MK1KS
				29.3	TAWNH2930T	□	□								
				29.4	TAWNH2940T	□	□								
29.5 30.4	3	TAWSN3000S32	●	29.5	TAWNH2950T	●	□	104.2	125.2	185.2	32	WS508027T	TKY27T	WPT4405	MK1KS
				29.6	TAWNH2960T	□	□								
				29.7	TAWNH2970T	□	□								
	5	TAWMN3000S32	●	29.8	TAWNH2980T	□	□	167.2	195.2	255.2	32	WS508027T	TKY27T	WPT4405	MK1KS
				29.9	TAWNH2990T	□	□								
				30.0	TAWNH3000T	●	□								
				30.1	TAWNH3010T	□	□								
				30.2	TAWNH3020T	□	□								
				30.3	TAWNH3030T	□	□								
	8 <small>NEW</small>	TAWLN3000S32	●	30.2	TAWNH3020T	□	□	250	285	345	32	WS508027T	TKY27T	WPT4405	MK1KS
				30.3	TAWNH3030T	□	□								
				30.4	TAWNH3040T	□	□								

TAW DRILLS



Ø 27.5~30.4

CUTTING CONDITIONS



D162

D159

DRILLING (INDEXABLE TYPE)

TAW

- Wavy cutting edge design for good chip control.
- Serration geometry for accurate insert location.
- Easy insert exchange.



P ✓ **M** **K** ✓ **S** **N** **H**

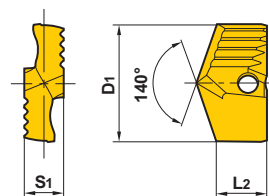

TAW INSERTS



Ø 14.0~22.9

Order Number	Stock		Dimensions (mm)			Applicable Holder
	VP15TF	VP10H	D1	L2	S1	
TAWNH1400T	●	□	14.0	7.6	5.0	TAWSNH1400S16
1410T	●	□	14.1	7.6	5.0	TAWSNH1400S16
1420T	●	□	14.2	7.6	5.0	TAWSNH1400S16
1430T	●	□	14.3	7.6	5.0	TAWSNH1400S16
1440T	●	□	14.4	7.6	5.0	TAWSNH1400S16
1450T	●	□	14.5	7.5	5.0	TAWSNH1500S20
1460T	●	□	14.6	7.5	5.0	TAWSNH1500S20
1470T	●	□	14.7	7.5	5.0	TAWSNH1500S20
1480T	●	□	14.8	7.5	5.0	TAWSNH1500S20
1490T	●	□	14.9	7.5	5.0	TAWSNH1500S20
1500T	●	□	15.0	7.4	5.0	TAWSNH1500S20
1510T	●	□	15.1	7.4	5.0	TAWSNH1500S20
1520T	●	□	15.2	7.4	5.0	TAWSNH1500S20
1530T	●	□	15.3	7.4	5.0	TAWSNH1500S20
1540T	●	□	15.4	7.4	5.0	TAWSNH1500S20
1550T	●	□	15.5	7.9	6.0	TAWSNH1600S20
1560T	●	□	15.6	7.9	6.0	TAWSNH1600S20
1570T	●	□	15.7	7.9	6.0	TAWSNH1600S20
1580T	●	□	15.8	7.9	6.0	TAWSNH1600S20
1590T	●	□	15.9	7.9	6.0	TAWSNH1600S20
1600T	●	□	16.0	7.8	6.0	TAWSNH1600S20
1610T	●	□	16.1	7.8	6.0	TAWSNH1600S20
1620T	●	□	16.2	7.8	6.0	TAWSNH1600S20
1630T	●	□	16.3	7.8	6.0	TAWSNH1600S20
1640T	●	□	16.4	7.8	6.0	TAWSNH1600S20
1650T	●	□	16.5	7.7	6.0	TAWSNH1700S20
1660T	●	□	16.6	7.7	6.0	TAWSNH1700S20
1670T	●	□	16.7	7.7	6.0	TAWSNH1700S20
1680T	●	□	16.8	7.7	6.0	TAWSNH1700S20
1690T	●	□	16.9	7.7	6.0	TAWSNH1700S20
1700T	●	□	17.0	7.6	6.0	TAWSNH1700S20
1710T	●	□	17.1	7.6	6.0	TAWSNH1700S20
1720T	●	□	17.2	7.6	6.0	TAWSNH1700S20
1730T	●	□	17.3	7.6	6.0	TAWSNH1700S20
1740T	●	□	17.4	7.6	6.0	TAWSNH1700S20
1750T	●	□	17.5	7.5	6.0	TAWSNH1800S20
1760T	●	□	17.6	7.5	6.0	TAWSNH1800S20
1770T	●	□	17.7	7.5	6.0	TAWSNH1800S20
1780T	●	□	17.8	7.5	6.0	TAWSNH1800S20
1790T	●	□	17.9	7.5	6.0	TAWSNH1800S20
1800T	●	□	18.0	7.4	6.0	TAWSNH1800S20
1810T	●	□	18.1	7.4	6.0	TAWSNH1800S20
1820T	●	□	18.2	7.4	6.0	TAWSNH1800S20
1830T	●	□	18.3	7.4	6.0	TAWSNH1800S20
1840T	●	□	18.4	7.4	6.0	TAWSNH1800S20

Order Number	Stock		Dimensions (mm)			Applicable Holder
	VP15TF	VP10H	D1	L2	S1	
TAWNH1850T	●	□	18.5	9.3	7.0	TAWSNH1900S25
1860T	●	□	18.6	9.3	7.0	TAWSNH1900S25
1870T	●	□	18.7	9.3	7.0	TAWSNH1900S25
1880T	●	□	18.8	9.3	7.0	TAWSNH1900S25
1890T	●	□	18.9	9.3	7.0	TAWSNH1900S25
1900T	●	□	19.0	9.2	7.0	TAWSNH1900S25
1910T	●	□	19.1	9.2	7.0	TAWSNH1900S25
1920T	●	□	19.2	9.2	7.0	TAWSNH1900S25
1930T	●	□	19.3	9.2	7.0	TAWSNH1900S25
1940T	●	□	19.4	9.2	7.0	TAWSNH1900S25
1950T	●	□	19.5	9.1	7.0	TAWSNH2000S25
1960T	●	□	19.6	9.1	7.0	TAWSNH2000S25
1970T	●	□	19.7	9.1	7.0	TAWSNH2000S25
1980T	●	□	19.8	9.1	7.0	TAWSNH2000S25
1990T	●	□	19.9	9.1	7.0	TAWSNH2000S25
2000T	●	□	20.0	9.0	7.0	TAWSNH2000S25
2010T	□	□	20.1	9.0	7.0	TAWSNH2000S25
2020T	□	□	20.2	9.0	7.0	TAWSNH2000S25
2030T	□	□	20.3	9.0	7.0	TAWSNH2000S25
2040T	□	□	20.4	9.0	7.0	TAWSNH2000S25
2050T	●	□	20.5	8.9	7.0	TAWSNH2100S25
2060T	□	□	20.6	8.9	7.0	TAWSNH2100S25
2070T	□	□	20.7	8.9	7.0	TAWSNH2100S25
2080T	□	□	20.8	8.9	7.0	TAWSNH2100S25
2090T	□	□	20.9	8.9	7.0	TAWSNH2100S25
2100T	●	□	21.0	8.8	7.0	TAWSNH2100S25
2110T	□	□	21.1	8.8	7.0	TAWSNH2100S25
2120T	□	□	21.2	8.8	7.0	TAWSNH2100S25
2130T	□	□	21.3	8.8	7.0	TAWSNH2100S25
2140T	□	□	21.4	8.8	7.0	TAWSNH2100S25
2150T	●	□	21.5	10.6	8.0	TAWSNH2200S25
2160T	□	□	21.6	10.6	8.0	TAWSNH2200S25
2170T	□	□	21.7	10.6	8.0	TAWSNH2200S25
2180T	□	□	21.8	10.6	8.0	TAWSNH2200S25
2190T	□	□	21.9	10.6	8.0	TAWSNH2200S25
2200T	●	□	22.0	10.5	8.0	TAWSNH2200S25
2210T	□	□	22.1	10.5	8.0	TAWSNH2200S25
2220T	□	□	22.2	10.5	8.0	TAWSNH2200S25
2230T	□	□	22.3	10.5	8.0	TAWSNH2200S25
2240T	□	□	22.4	10.5	8.0	TAWSNH2200S25
2250T	●	□	22.5	10.4	8.0	TAWSNH2300S25
2260T	□	□	22.6	10.4	8.0	TAWSNH2300S25
2270T	□	□	22.7	10.4	8.0	TAWSNH2300S25
2280T	□	□	22.8	10.4	8.0	TAWSNH2300S25
2290T	□	□	22.9	10.4	8.0	TAWSNH2300S25

- : Stock Standard
- ★ : Stock Standard in Japan.
- : Non stock, produced to order only

Order Number	Stock		Dimensions (mm)			Applicable Holder
	VP15TF	VP10H	D1	L2	S1	
TAWNH2300T	●	□	23.0	10.3	8.0	TAWSN
2310T	□	□	23.1	10.3	8.0	2300S25
2320T	□	□	23.2	10.3	8.0	TAWMN
2330T	□	□	23.3	10.3	8.0	2300S25
2340T	□	□	23.4	10.3	8.0	TAWLN
2350T	●	□	23.5	10.2	8.0	2300S25
2360T	□	□	23.6	10.2	8.0	
2370T	□	□	23.7	10.2	8.0	TAWSN
2380T	□	□	23.8	10.2	8.0	2400S32
2390T	□	□	23.9	10.2	8.0	TAWMN
2400T	●	□	24.0	10.1	8.0	2400S32
2410T	□	□	24.1	10.1	8.0	TAWLN
2420T	□	□	24.2	10.1	8.0	2400S32
2430T	□	□	24.3	10.1	8.0	
2440T	□	□	24.4	10.1	8.0	
2450T	●	□	24.5	11.7	9.0	
2460T	□	□	24.6	11.7	9.0	
2470T	□	□	24.7	11.7	9.0	TAWSN
2480T	□	□	24.8	11.7	9.0	2500S32
2490T	□	□	24.9	11.7	9.0	TAWMN
2500T	●	□	25.0	11.6	9.0	2500S32
2510T	□	□	25.1	11.6	9.0	TAWLN
2520T	□	□	25.2	11.6	9.0	2500S32
2530T	□	□	25.3	11.6	9.0	
2540T	□	□	25.4	11.6	9.0	
2550T	●	□	25.5	11.5	9.0	
2560T	□	□	25.6	11.5	9.0	
2570T	□	□	25.7	11.5	9.0	TAWSN
2580T	□	□	25.8	11.5	9.0	2600S32
2590T	□	□	25.9	11.5	9.0	TAWMN
2600T	●	□	26.0	11.4	9.0	2600S32
2610T	□	□	26.1	11.4	9.0	TAWLN
2620T	□	□	26.2	11.4	9.0	2600S32
2630T	□	□	26.3	11.4	9.0	
2640T	□	□	26.4	11.4	9.0	
2650T	●	□	26.5	11.3	9.0	
2660T	□	□	26.6	11.3	9.0	
2670T	□	□	26.7	11.3	9.0	TAWSN
2680T	□	□	26.8	11.3	9.0	2700S32
2690T	□	□	26.9	11.3	9.0	TAWMN
2700T	●	□	27.0	11.2	9.0	2700S32
2710T	□	□	27.1	11.2	9.0	TAWLN
2720T	□	□	27.2	11.2	9.0	2700S32
2730T	□	□	27.3	11.2	9.0	
2740T	□	□	27.4	11.2	9.0	

Order Number	Stock		Dimensions (mm)			Applicable Holder
	VP15TF	VP10H	D1	L2	S1	
TAWNH2750T	●	□	27.5	12.3	10.0	
2760T	□	□	27.6	12.3	10.0	
2770T	□	□	27.7	12.3	10.0	TAWSN
2780T	□	□	27.8	12.3	10.0	2800S32
2790T	□	□	27.9	12.3	10.0	TAWMN
2800T	●	□	28.0	12.2	10.0	2800S32
2810T	□	□	28.1	12.2	10.0	TAWLN
2820T	□	□	28.2	12.2	10.0	2800S32
2830T	□	□	28.3	12.2	10.0	
2840T	□	□	28.4	12.2	10.0	
2850T	●	□	28.5	12.1	10.0	
2860T	□	□	28.6	12.1	10.0	
2870T	□	□	28.7	12.1	10.0	TAWSN
2880T	□	□	28.8	12.1	10.0	2900S32
2890T	□	□	28.9	12.1	10.0	TAWMN
2900T	●	□	29.0	12.0	10.0	2900S32
2910T	□	□	29.1	12.0	10.0	TAWLN
2920T	□	□	29.2	12.0	10.0	2900S32
2930T	□	□	29.3	12.0	10.0	
2940T	□	□	29.4	12.0	10.0	
2950T	●	□	29.5	11.9	10.0	
2960T	□	□	29.6	11.9	10.0	
2970T	□	□	29.7	11.9	10.0	TAWSN
2980T	□	□	29.8	11.9	10.0	3000S32
2990T	□	□	29.9	11.9	10.0	TAWMN
3000T	●	□	30.0	11.8	10.0	3000S32
3010T	□	□	30.1	11.8	10.0	TAWLN
3020T	□	□	30.2	11.8	10.0	3000S32
3030T	□	□	30.3	11.8	10.0	
3040T	□	□	30.4	11.8	10.0	

TAW INSERTS



Ø 23.0~30.4

RECOMMENDED CUTTING CONDITIONS

Work Material	Drill Diameter	Conditions Hardness	φ14.0—φ15.4		φ15.5—φ18.4		φ18.5—φ21.4	
			Cutting Speed (m/min)	Feed (mm/rev)	Cutting Speed (m/min)	Feed (mm/rev)	Cutting Speed (m/min)	Feed (mm/rev)
P Mild Steel	≤180HB		70 (60—90)	0.20 (0.15—0.25)	80 (60—100)	0.25 (0.20—0.30)	90 (70—110)	0.25 (0.20—0.30)
			Carbon Steel Alloy Steel	180—280HB	70 (60—90)	0.20 (0.15—0.25)	80 (60—100)	0.25 (0.20—0.30)
M Stainless Steel	≤200HB		60 (50—80)	0.15 (0.12—0.18)	70 (50—90)	0.20 (0.15—0.25)	70 (50—90)	0.20 (0.15—0.25)
			K Cast Iron	280—350HB	60 (50—80)	0.15 (0.12—0.18)	70 (50—90)	0.20 (0.15—0.25)
K Cast Iron	Tensile Strength ≤350N/mm ²		50 (40—60)	0.15 (0.12—0.18)	50 (40—60)	0.15 (0.12—0.18)	60 (50—70)	0.20 (0.15—0.22)
			Ductile Cast Iron	Tensile Strength ≤450N/mm ²	70 (50—90)	0.20 (0.15—0.25)	80 (60—90)	0.25 (0.20—0.30)
K Ductile Cast Iron	Tensile Strength ≤450N/mm ²		70 (50—90)	0.20 (0.15—0.25)	80 (60—90)	0.25 (0.20—0.30)	80 (60—90)	0.25 (0.20—0.30)

Work Material	Drill Diameter	Conditions Hardness	φ21.5—φ24.4		φ24.5—φ27.4		φ27.5—φ30.4	
			Cutting Speed (m/min)	Feed (mm/rev)	Cutting Speed (m/min)	Feed (mm/rev)	Cutting Speed (m/min)	Feed (mm/rev)
P Mild Steel	≤180HB		100 (80—120)	0.30 (0.25—0.35)	110 (80—120)	0.30 (0.25—0.35)	110 (80—120)	0.30 (0.25—0.35)
			Carbon Steel Alloy Steel	180—280HB	90 (70—110)	0.30 (0.25—0.35)	100 (80—120)	0.30 (0.25—0.35)
M Stainless Steel	≤200HB		80 (60—100)	0.25 (0.20—0.30)	90 (70—110)	0.25 (0.20—0.30)	90 (70—110)	0.25 (0.20—0.30)
			K Cast Iron	280—350HB	80 (60—100)	0.25 (0.20—0.30)	90 (70—110)	0.25 (0.20—0.30)
K Cast Iron	Tensile Strength ≤350N/mm ²		60 (50—70)	0.20 (0.15—0.22)	70 (60—80)	0.25 (0.20—0.28)	70 (60—80)	0.25 (0.20—0.28)
			Ductile Cast Iron	Tensile Strength ≤450N/mm ²	100 (80—110)	0.35 (0.25—0.40)	110 (90—120)	0.35 (0.25—0.40)
K Ductile Cast Iron	Tensile Strength ≤450N/mm ²		90 (60—100)	0.30 (0.25—0.35)	100 (80—110)	0.30 (0.25—0.35)	100 (80—110)	0.30 (0.25—0.35)

(Note 1) H type honing is recommended when machining mild steel and stainless steel.

(Note 2) Recommended for use only with a rigid machine and set up. Use the internal coolant system when machining stainless steel. (MQL and mist machining should not be used.)

HONE WIDTH

If an insert with honing other than standard is needed, please order using the symbols below.

(Insert Order Number)

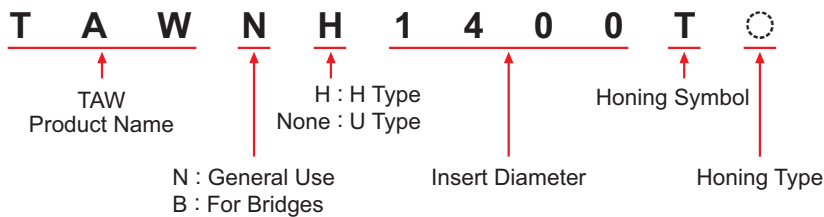

(Honing Standard)

Honing Type	Hone Width (mm)
F	0
G	0.02—0.05
H	0.05—0.10
-(Standard)	0.10—0.15
K	0.15—0.20
S	0.20—0.25
M	0.25—0.30

NOTES ON USE

INSERT INSTALLATION

- Remove the clamp screw to install the insert. (H type insert)
- Loosen the clamp screw to install the insert. (U type insert)
- Correctly mesh the insert and the holder serrations, then slide the insert to the bottom of the slot.
- Fasten the clamp screw using the torque wrench provided while holding the insert lightly as shown. (Figure 1)
- Check there is no gap between the bottom of the insert and holder. (Figure 2)

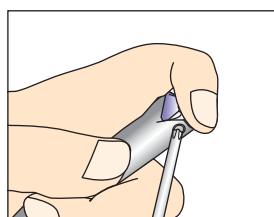
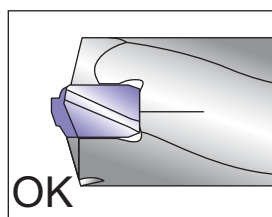
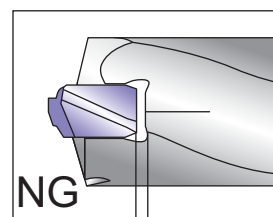

Fig. 1



OK



NG

Fig. 2

← Clearance

INSERT REPLACEMENT

- Thoroughly clean the serrations of the holder before installing a new insert. Remove heavy dirt in the holder serrations by using the cleaning plate provided.

For Bridge Construction Parts

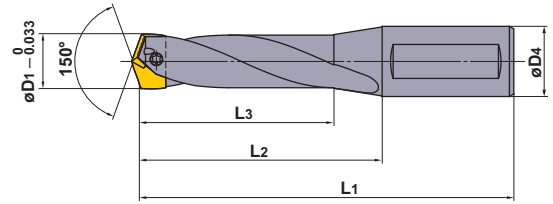

Drill Dia. Range D1 (mm)	Hole Depth (l/d)	Holder		Insert		Dimensions (mm)				Clamp Screw	Wrench	Plate	Anti-seize Lubricant	
		Order Number	Stock	Drill Dia. D1 (mm)	Order Number	Stock	L3	L2	L1					D4
24.5 24.6 24.7	3	TAWSB2500S32	●	24.5	TAWB2450T	★	88.6	110.6	170.6	32	WS406023T	TKY25T	WPT4405	MK1KS
					TAWBH2450T	●								
	5	TAWMB2500S32	□	24.6	TAWB2460T	□	140.6	165.6	225.6	32	WS406023T	TKY25T	WPT4405	MK1KS
					TAWBH2460T	□								
					TAWB2470T	★								
26.5 26.7	3	TAWSB2700S32	●	26.5	TAWB2650T	□	94.6	115.6	175.6	32	WS406024T	TKY25T	WPT4405	MK1KS
					TAWBH2650T	□								
	5	TAWMB2700S32	□	26.7	TAWB2670T	★	151.6	175.6	235.6	32	WS406024T	TKY25T	WPT4405	MK1KS
					TAWBH2670T	●								

(Note 1) The dimensions in brackets represent the sizes when TAWN-U type inserts are used.

(Note 2) Please contact us for any geometry that is not in this catalogue (e.g. different diameter and length).

INSERTS

Shape	Order Number	Stock	Dimensions (mm)			Applicable Holder	Honing Width (mm)	Geometry
			D1	L2	S1			
	TAWBH2450T	●	24.5	11.7	9.0	TAWSB2500S32 TAWMB2500S32	0.20-0.25	
	2460T	□	24.6	11.7	9.0			
	2470T	●	24.7	11.7	9.0			
	2650T	□	26.5	11.3	9.0	TAWSB2700S32 TAWMB2700S32		
	2670T	●	26.7	11.3	9.0			

RECOMMENDED CUTTING CONDITIONS

Work Material	Drill Diameter		φ24.5, φ24.6, φ24.7		φ26.5, φ26.7	
	Conditions	Hardness	Cutting Speed (m/min)	Feed (mm/rev)	Cutting Speed (m/min)	Feed (mm/rev)
P Structural Steel	Tensile Strength ≤ 400-500 N/mm ²		70 (60-80)	0.30 (0.25-0.35)	70 (60-80)	0.30 (0.25-0.35)
	Tensile Strength ≤ 490-610 N/mm ²		65 (55-75)	0.30 (0.25-0.35)	65 (55-75)	0.30 (0.25-0.35)
	Tensile Strength ≤ 570-720 N/mm ²		60 (50-70)	0.30 (0.25-0.35)	60 (50-70)	0.30 (0.25-0.35)

(Note) Recommended for use only with a rigid machine and set up. Use the internal coolant system when machining stainless steel. (MQL and mist machining should not be used.)

● : Stock Standard
□ : Non stock, produced to order only



TAF

Stable machining and a wide application area.
Low drilling noise and tough body with
economical, 4 cutting edges per insert.



PRECISION
FOR SUCCESS

CHOOSE JAPAN'S NO. 1

MITSUBISHI
MITSUBISHI MATERIALS

www.mitsubishicarbide.com

Indexable Type Drill

TAF

Features

Tough Body

- ① The new, wider web design reduces chattering. Cutting noise is lowered.
- ② High insert seat rigidity for reliable insert location.

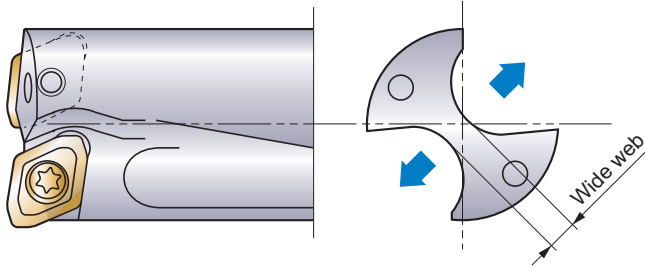

Economical Insert

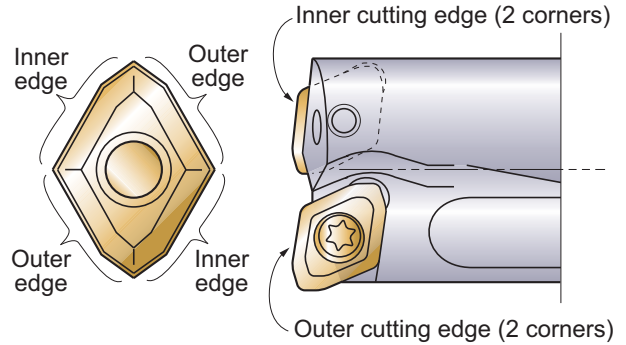

Economical four corner use

Grade Selection

Grade Breaker	VP15TF		UP20M		GP20M		UE6020		US735		F5010	
	GCMT	GPMT	GCMT	GPMT	GCMT	GPMT	GCMT	GPMT	GCMT	GPMT	GCMT	GPMT
U1			Mild steel	Mild steel								
U2	Carbon steel Alloy steel Stainless steel Cast iron Ductile cast iron	Stainless steel			Carbon steel Alloy steel Stainless steel Cast iron Ductile cast iron					Stainless steel		
U3				Ductile cast iron				Carbon steel Alloy steel				Cast iron Ductile cast iron

Description & Identification

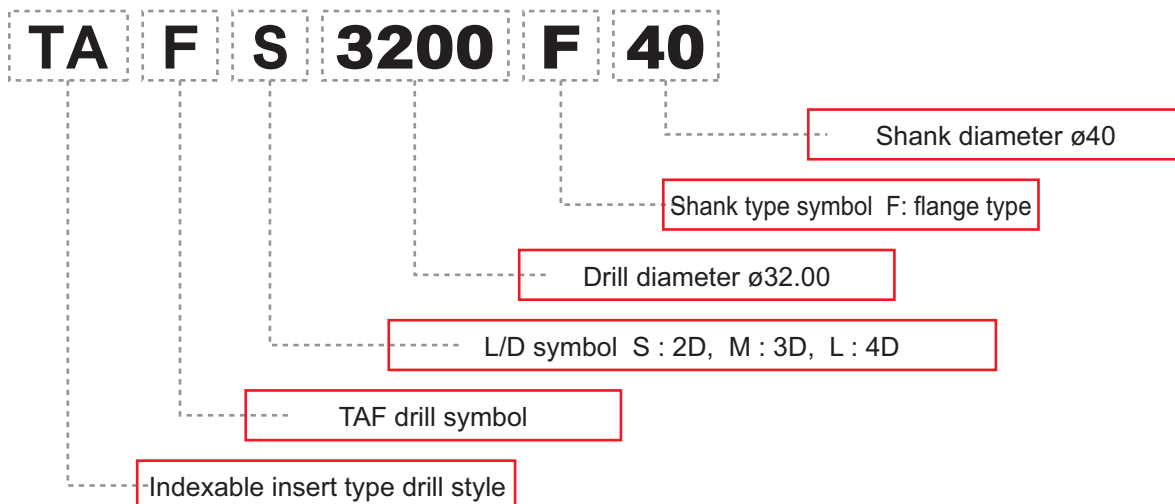

DRILLING (INDEXABLE TYPE)

TAFS, TAFM, TAFL

- High rigidity holder.
- 4 corner use insert.
- Various grades and chip breakers.

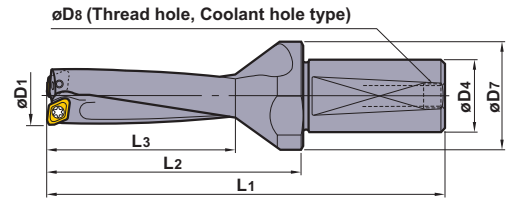
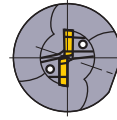

* The screw hole on the flange section is not a coolant hole.



TAF DRILLS

DRILLING

Ø 12.0~17.5

Drill Diameter D1 (mm)	Hole Depth (l/d)	Order Number	Stock	Number of Teeth	Dimensions (mm)						Insert Number	Clamp Screw	Wrench
					D4	D7	D8	L1	L2	L3			
12.0	2	TAFS1200F20	●	2	20	25	PT1/8	82	39	29	GCMT040204-U	TS2	TKY06F
	3	TAFM1200F20	●	2	20	25	PT1/8	94	51	41	GCMT040204-U	TS2	TKY06F
	4	TAFL1200F20	●	2	20	25	PT1/8	106	63	53	GCMT040204-U	TS2	TKY06F
12.5	2	TAFS1250F20	●	2	20	25	PT1/8	82	39	29	GCMT040204-U	TS2	TKY06F
	3	TAFM1250F20	●	2	20	25	PT1/8	94	51	41	GCMT040204-U	TS2	TKY06F
	4	TAFL1250F20	●	2	20	25	PT1/8	106	63	53	GCMT040204-U	TS2	TKY06F
13.0	2	TAFS1300F20	●	2	20	25	PT1/8	84	41	31	GCMT040204-U	TS2	TKY06F
	3	TAFM1300F20	●	2	20	25	PT1/8	97	54	44	GCMT040204-U	TS2	TKY06F
	4	TAFL1300F20	●	2	20	25	PT1/8	110	67	57	GCMT040204-U	TS2	TKY06F
13.5	2	TAFS1350F20	●	2	20	25	PT1/8	84	41	31	GCMT040204-U	TS2	TKY06F
	3	TAFM1350F20	●	2	20	25	PT1/8	97	54	44	GCMT040204-U	TS2	TKY06F
	4	TAFL1350F20	●	2	20	25	PT1/8	110	67	57	GCMT040204-U	TS2	TKY06F
14.0	2	TAFS1400F20	●	2	20	25	PT1/8	86	43	33	GCMT040204-U	TS2	TKY06F
	3	TAFM1400F20	●	2	20	25	PT1/8	100	57	47	GCMT040204-U	TS2	TKY06F
	4	TAFL1400F20	●	2	20	25	PT1/8	114	71	61	GCMT040204-U	TS2	TKY06F
14.5	2	TAFS1450F20	●	2	20	25	PT1/8	86	43	33	GCMT040204-U	TS2	TKY06F
	3	TAFM1450F20	●	2	20	25	PT1/8	100	57	47	GCMT040204-U	TS2	TKY06F
	4	TAFL1450F20	●	2	20	25	PT1/8	114	71	61	GCMT040204-U	TS2	TKY06F
15.0	2	TAFS1500F20	●	2	20	25	PT1/8	88	45	35	GPMT060204-U	TS2	TKY06F
	3	TAFM1500F20	●	2	20	25	PT1/8	103	60	50	GPMT060204-U	TS2	TKY06F
	4	TAFL1500F20	●	2	20	25	PT1/8	118	75	65	GPMT060204-U	TS2	TKY06F
15.5	2	TAFS1550F20	●	2	20	25	PT1/8	88	45	35	GPMT060204-U	TS2	TKY06F
	3	TAFM1550F20	●	2	20	25	PT1/8	103	60	50	GPMT060204-U	TS2	TKY06F
	4	TAFL1550F20	●	2	20	25	PT1/8	118	75	65	GPMT060204-U	TS2	TKY06F
16.0	2	TAFS1600F25	●	2	25	35	PT1/8	107	57	38	GPMT060204-U	TS2	TKY06F
	3	TAFM1600F25	●	2	25	35	PT1/8	123	73	54	GPMT060204-U	TS2	TKY06F
	4	TAFL1600F25	●	2	25	35	PT1/8	139	89	70	GPMT060204-U	TS2	TKY06F
16.5	2	TAFS1650F25	●	2	25	35	PT1/8	107	57	38	GPMT060204-U	TS2	TKY06F
	3	TAFM1650F25	●	2	25	35	PT1/8	123	73	54	GPMT060204-U	TS2	TKY06F
17.0	2	TAFS1700F25	●	2	25	35	PT1/8	109	59	41	GPMT060204-U	TS2	TKY06F
	3	TAFM1700F25	●	2	25	35	PT1/8	126	76	58	GPMT060204-U	TS2	TKY06F
	4	TAFL1700F25	●	2	25	35	PT1/8	143	93	75	GPMT060204-U	TS2	TKY06F
17.5	2	TAFS1750F25	●	2	25	35	PT1/8	109	59	41	GPMT060204-U	TS2	TKY06F
	3	TAFM1750F25	●	2	25	35	PT1/8	126	76	58	GPMT060204-U	TS2	TKY06F
	4	TAFL1750F25	●	2	25	35	PT1/8	143	93	75	GPMT060204-U	TS2	TKY06F

- : Stock Standard
- ★ : Stock Standard in Japan.
- : Non stock, produced to order only

Drill Diameter D1 (mm)	Hole Depth (l/d)	Order Number	Stock	Number of Teeth	Dimensions (mm)						Insert Number		
					D4	D7	D8	L1	L2	L3			
18.0	2	TAFS1800F25	●	2	25	35	PT1/8	111	61	43	GPMT070204-U	TS25	TKY08F
	3	TAFM1800F25	●	2	25	35	PT1/8	129	79	61	GPMT070204-U	TS25	TKY08F
	4	T AFL1800F25	●	2	25	35	PT1/8	147	97	79	GPMT070204-U	TS25	TKY08F
18.5	2	TAFS1850F25	●	2	25	35	PT1/8	111	61	43	GPMT070204-U	TS25	TKY08F
	3	TAFM1850F25	●	2	25	35	PT1/8	129	79	61	GPMT070204-U	TS25	TKY08F
19.0	2	TAFS1900F25	●	2	25	35	PT1/8	113	63	46	GPMT070204-U	TS25	TKY08F
	3	TAFM1900F25	●	2	25	35	PT1/8	132	82	65	GPMT070204-U	TS25	TKY08F
	4	T AFL1900F25	●	2	25	35	PT1/8	151	101	84	GPMT070204-U	TS25	TKY08F
19.5	2	TAFS1950F25	●	2	25	35	PT1/8	113	63	46	GPMT070204-U	TS25	TKY08F
	3	TAFM1950F25	●	2	25	35	PT1/8	132	82	65	GPMT070204-U	TS25	TKY08F
20.0	2	TAFS2000F25	●	2	25	35	PT1/8	115	65	48	GPMT070204-U	TS25	TKY08F
	3	TAFM2000F25	●	2	25	35	PT1/8	135	85	68	GPMT070204-U	TS25	TKY08F
	4	T AFL2000F25	●	2	25	35	PT1/8	155	105	88	GPMT070204-U	TS25	TKY08F
20.5	2	TAFS2050F25	●	2	25	35	PT1/8	115	65	48	GPMT070204-U	TS25	TKY08F
	3	TAFM2050F25	●	2	25	35	PT1/8	135	85	68	GPMT070204-U	TS25	TKY08F
21.0	2	TAFS2100F25	●	2	25	35	PT1/8	117	67	50	GPMT070204-U	TS25	TKY08F
	3	TAFM2100F25	●	2	25	35	PT1/8	138	88	71	GPMT070204-U	TS25	TKY08F
	4	T AFL2100F25	●	2	25	35	PT1/8	159	109	92	GPMT070204-U	TS25	TKY08F
21.5	2	TAFS2150F25	●	2	25	35	PT1/8	117	67	50	GPMT070204-U	TS25	TKY08F
	3	TAFM2150F25	●	2	25	35	PT1/8	138	88	71	GPMT070204-U	TS25	TKY08F
22.0	2	TAFS2200F25	●	2	25	35	PT1/8	119	69	53	GPMT070204-U	TS25	TKY08F
	3	TAFM2200F25	●	2	25	35	PT1/8	141	91	75	GPMT070204-U	TS25	TKY08F
	4	T AFL2200F25	●	2	25	35	PT1/8	163	113	97	GPMT070204-U	TS25	TKY08F
22.5	2	TAFS2250F25	●	2	25	35	PT1/8	119	69	53	GPMT070204-U	TS25	TKY08F
	3	TAFM2250F25	●	2	25	35	PT1/8	141	91	75	GPMT070204-U	TS25	TKY08F
23.0	2	TAFS2300F25	●	2	25	35	PT1/8	121	71	55	GPMT090304-U	TS3	TKY08F
	3	TAFM2300F25	●	2	25	35	PT1/8	144	94	78	GPMT090304-U	TS3	TKY08F
	4	T AFL2300F25	●	2	25	35	PT1/8	167	117	101	GPMT090304-U	TS3	TKY08F
23.5	2	TAFS2350F25	●	2	25	35	PT1/8	121	71	55	GPMT090304-U	TS3	TKY08F
	3	TAFM2350F25	●	2	25	35	PT1/8	144	94	78	GPMT090304-U	TS3	TKY08F
	4	T AFL2350F25	●	2	25	35	PT1/8	167	117	101	GPMT090304-U	TS3	TKY08F
24.0	2	TAFS2400F25	●	2	25	35	PT1/8	123	73	58	GPMT090304-U	TS3	TKY08F
	3	TAFM2400F25	●	2	25	35	PT1/8	147	97	82	GPMT090304-U	TS3	TKY08F
	4	T AFL2400F25	●	2	25	35	PT1/8	171	121	106	GPMT090304-U	TS3	TKY08F
24.5	2	TAFS2450F25	●	2	25	35	PT1/8	123	73	58	GPMT090304-U	TS3	TKY08F
	3	TAFM2450F25	●	2	25	35	PT1/8	147	97	82	GPMT090304-U	TS3	TKY08F
25.0	2	TAFS2500F32	●	2	32	42	PT1/8	130	75	60	GPMT090304-U	TS3	TKY08F
	3	TAFM2500F32	●	2	32	42	PT1/8	155	100	85	GPMT090304-U	TS3	TKY08F
	4	T AFL2500F25	●	2	25	35	PT1/8	180	125	110	GPMT090304-U	TS3	TKY08F
	4	T AFL2500F32	●	2	32	42	PT1/8	180	125	110	GPMT090304-U	TS3	TKY08F
25.5	2	TAFS2550F32	●	2	32	42	PT1/8	130	75	60	GPMT090304-U	TS3	TKY08F
	3	TAFM2550F32	●	2	32	42	PT1/8	155	100	85	GPMT090304-U	TS3	TKY08F
26.0	2	TAFS2600F32	●	2	32	42	PT1/8	132	77	62	GPMT090304-U	TS3	TKY08F
	3	TAFM2600F32	●	2	32	42	PT1/8	158	103	88	GPMT090304-U	TS3	TKY08F
	4	T AFL2600F32	●	2	32	42	PT1/8	184	129	114	GPMT090304-U	TS3	TKY08F
26.5	2	TAFS2650F32	●	2	32	42	PT1/8	132	77	62	GPMT090304-U	TS3	TKY08F
	3	TAFM2650F32	●	2	32	42	PT1/8	158	103	88	GPMT090304-U	TS3	TKY08F
	4	T AFL2650F32	●	2	32	42	PT1/8	184	129	114	GPMT090304-U	TS3	TKY08F

TAF DRILLS



Ø 18.0~26.5

CUTTING CONDITIONS



D174

D167

DRILLING (INDEXABLE TYPE)

TAFS, TAFM, TAFL

- High rigidity holder.
- 4 corner use insert.
- Various grades and chip breakers.

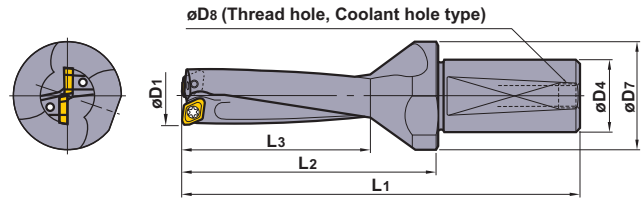

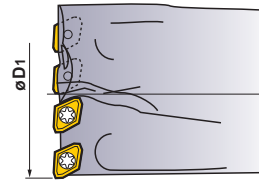

* The screw hole on the flange section is not a coolant hole.





Number of Teeth = 4 (øD1 ≥ 49)

TAF DRILLS

Drill Diameter D1 (mm)	Hole Depth (l/d)	Order Number	Stock	Number of Teeth	Dimensions (mm)						Insert Number	 Clamp Screw	 Wrench
					D4	D7	D8	L1	L2	L3			
27.0	2	TAFS2700F32	●	2	32	42	PT1/8	134	79	65	GPMT090304-U	TS3	①TKY08F
	3	TAFM2700F32	●	2	32	42	PT1/8	161	106	92	GPMT090304-U	TS3	①TKY08F
	4	TAFL2700F32	●	2	32	42	PT1/8	188	133	119	GPMT090304-U	TS3	①TKY08F
27.5	2	TAFS2750F32	●	2	32	42	PT1/8	134	79	65	GPMT090304-U	TS3	①TKY08F
	3	TAFM2750F32	●	2	32	42	PT1/8	161	106	92	GPMT090304-U	TS3	①TKY08F
28.0	2	TAFS2800F32	●	2	32	42	PT1/8	136	81	67	GPMT11T308-U	TS4	②TKY15D
	3	TAFM2800F32	●	2	32	42	PT1/8	164	109	95	GPMT11T308-U	TS4	②TKY15D
	4	TAFL2800F32	●	2	32	42	PT1/8	192	137	123	GPMT11T308-U	TS4	②TKY15D
28.5	2	TAFS2850F32	●	2	32	42	PT1/8	136	81	67	GPMT11T308-U	TS4	②TKY15D
	3	TAFM2850F32	●	2	32	42	PT1/8	164	109	95	GPMT11T308-U	TS4	②TKY15D
	4	TAFL2850F40	●	2	40	50	PT1/8	202	137	123	GPMT11T308-U	TS4	②TKY15D
29.0	2	TAFS2900F32	●	2	32	42	PT1/8	138	83	70	GPMT11T308-U	TS4	②TKY15D
	3	TAFM2900F32	●	2	32	42	PT1/8	167	112	99	GPMT11T308-U	TS4	②TKY15D
	4	TAFL2900F32	●	2	32	42	PT1/8	196	141	128	GPMT11T308-U	TS4	②TKY15D
29.5	2	TAFS2950F32	●	2	32	42	PT1/8	138	83	70	GPMT11T308-U	TS4	②TKY15D
	3	TAFM2950F32	●	2	32	42	PT1/8	167	112	99	GPMT11T308-U	TS4	②TKY15D
30.0	2	TAFS3000F32	●	2	32	50	PT1/8	145	90	72	GPMT11T308-U	TS4	②TKY15D
	2	TAFS3000F40	●	2	40	50	PT1/4	155	90	72	GPMT11T308-U	TS4	②TKY15D
	3	TAFM3000F32	●	2	32	50	PT1/8	175	120	102	GPMT11T308-U	TS4	②TKY15D
	3	TAFM3000F40	●	2	40	50	PT1/4	185	120	102	GPMT11T308-U	TS4	②TKY15D
	4	TAFL3000F32	●	2	32	42	PT1/8	205	150	132	GPMT11T308-U	TS4	②TKY15D
30.5	2	TAFS3050F40	●	2	40	50	PT1/4	155	90	72	GPMT11T308-U	TS4	②TKY15D
	3	TAFM3050F40	●	2	40	50	PT1/4	185	120	102	GPMT11T308-U	TS4	②TKY15D
31.0	2	TAFS3100F32	●	2	32	50	PT1/8	147	92	74	GPMT11T308-U	TS4	②TKY15D
	2	TAFS3100F40	●	2	40	50	PT1/4	157	92	74	GPMT11T308-U	TS4	②TKY15D
	3	TAFM3100F32	●	2	32	50	PT1/8	178	123	105	GPMT11T308-U	TS4	②TKY15D
	3	TAFM3100F40	●	2	40	50	PT1/4	188	123	105	GPMT11T308-U	TS4	②TKY15D
	4	TAFL3100F32	●	2	32	42	PT1/8	209	154	136	GPMT11T308-U	TS4	②TKY15D
4	TAFL3100F40	●	2	40	50	PT1/4	219	154	136	GPMT11T308-U	TS4	②TKY15D	

● : Stock Standard
 ★ : Stock Standard in Japan.
 □ : Non stock, produced to order only

Drill Diameter D1 (mm)	Hole Depth (l/d)	Order Number	Stock	Number of Teeth	Dimensions (mm)						Insert Number		
					D4	D7	D8	L1	L2	L3			
32.0	2	TAFS3200F32	●	2	32	50	PT1/8	149	94	77	GPMT11T308-U	TS4	TKY15D
	2	TAFS3200F40	●	2	40	50	PT1/4	159	94	77	GPMT11T308-U	TS4	TKY15D
	3	TAFM3200F32	●	2	32	50	PT1/8	181	126	109	GPMT11T308-U	TS4	TKY15D
	3	TAFM3200F40	●	2	40	50	PT1/4	191	126	109	GPMT11T308-U	TS4	TKY15D
	4	T AFL3200F32	●	2	32	42	PT1/8	213	158	141	GPMT11T308-U	TS4	TKY15D
	4	T AFL3200F40	●	2	40	50	PT1/4	223	158	141	GPMT11T308-U	TS4	TKY15D
33.0	2	TAFS3300F32	●	2	32	50	PT1/8	151	96	79	GPMT11T308-U	TS4	TKY15D
	2	TAFS3300F40	●	2	40	50	PT1/4	161	96	79	GPMT11T308-U	TS4	TKY15D
	3	TAFM3300F32	●	2	32	50	PT1/8	184	129	112	GPMT11T308-U	TS4	TKY15D
	3	TAFM3300F40	●	2	40	50	PT1/4	194	129	112	GPMT11T308-U	TS4	TKY15D
	4	T AFL3300F32	●	2	32	42	PT1/8	217	162	145	GPMT11T308-U	TS4	TKY15D
	4	T AFL3300F40	●	2	40	50	PT1/4	227	162	145	GPMT11T308-U	TS4	TKY15D
34.0	2	TAFS3400F32	●	2	32	50	PT1/8	153	98	82	GPMT11T308-U	TS4	TKY15D
	2	TAFS3400F40	●	2	40	50	PT1/4	163	98	82	GPMT11T308-U	TS4	TKY15D
	3	TAFM3400F32	●	2	32	50	PT1/8	187	132	116	GPMT11T308-U	TS4	TKY15D
	3	TAFM3400F40	●	2	40	50	PT1/4	197	132	116	GPMT11T308-U	TS4	TKY15D
	4	T AFL3400F32	●	2	32	42	PT1/8	231	166	150	GPMT11T308-U	TS4	TKY15D
	4	T AFL3400F40	●	2	40	50	PT1/4	231	166	150	GPMT11T308-U	TS4	TKY15D
35.0	2	TAFS3500F32	●	2	32	50	PT1/8	155	100	84	GPMT140408-U	TS55	TKY25D
	2	TAFS3500F40	●	2	40	50	PT1/4	165	100	84	GPMT140408-U	TS55	TKY25D
	3	TAFM3500F32	●	2	32	50	PT1/8	190	135	119	GPMT140408-U	TS55	TKY25D
	3	TAFM3500F40	●	2	40	50	PT1/4	200	135	119	GPMT140408-U	TS55	TKY25D
	4	T AFL3500F32	●	2	32	42	PT1/8	235	170	154	GPMT140408-U	TS5	TKY25D
	4	T AFL3500F40	●	2	40	50	PT1/4	235	170	154	GPMT140408-U	TS5	TKY25D
36.0	2	TAFS3600F32	●	2	32	50	PT1/8	157	102	86	GPMT140408-U	TS55	TKY25D
	2	TAFS3600F40	●	2	40	50	PT1/4	167	102	86	GPMT140408-U	TS55	TKY25D
	3	TAFM3600F32	●	2	32	50	PT1/8	193	138	122	GPMT140408-U	TS55	TKY25D
	3	TAFM3600F40	●	2	40	50	PT1/4	203	138	122	GPMT140408-U	TS55	TKY25D
	4	T AFL3600F32	●	2	32	42	PT1/8	229	174	158	GPMT140408-U	TS5	TKY25D
	4	T AFL3600F40	●	2	40	50	PT1/4	239	174	158	GPMT140408-U	TS5	TKY25D
37.0	2	TAFS3700F32	●	2	32	50	PT1/8	159	104	89	GPMT140408-U	TS55	TKY25D
	2	TAFS3700F40	●	2	40	50	PT1/4	169	104	89	GPMT140408-U	TS55	TKY25D
	3	TAFM3700F32	●	2	32	50	PT1/8	196	141	126	GPMT140408-U	TS55	TKY25D
	3	TAFM3700F40	●	2	40	50	PT1/4	206	141	126	GPMT140408-U	TS55	TKY25D
	4	T AFL3700F32	●	2	32	42	PT1/8	233	178	163	GPMT140408-U	TS5	TKY25D
	4	T AFL3700F40	●	2	40	50	PT1/4	243	178	163	GPMT140408-U	TS5	TKY25D
37.5	2	TAFS3750F32	●	2	32	50	PT1/8	159	104	89	GPMT140408-U	TS55	TKY25D
	2	TAFS3750F40	●	2	40	50	PT1/4	169	104	89	GPMT140408-U	TS55	TKY25D
	3	TAFM3750F32	●	2	32	50	PT1/8	196	141	126	GPMT140408-U	TS55	TKY25D
	3	TAFM3750F40	●	2	40	50	PT1/4	206	141	126	GPMT140408-U	TS55	TKY25D
	4	T AFL3750F32	●	2	32	42	PT1/8	233	178	163	GPMT140408-U	TS5	TKY25D
	4	T AFL3750F40	●	2	40	50	PT1/4	243	178	163	GPMT140408-U	TS5	TKY25D
38.0	2	TAFS3800F32	●	2	32	50	PT1/8	161	106	91	GPMT140408-U	TS55	TKY25D
	2	TAFS3800F40	●	2	40	50	PT1/4	171	106	91	GPMT140408-U	TS55	TKY25D
	3	TAFM3800F32	●	2	32	50	PT1/8	199	144	129	GPMT140408-U	TS55	TKY25D
	3	TAFM3800F40	●	2	40	50	PT1/4	209	144	129	GPMT140408-U	TS55	TKY25D
	4	T AFL3800F32	●	2	32	42	PT1/8	247	182	167	GPMT140408-U	TS5	TKY25D
	4	T AFL3800F40	●	2	40	50	PT1/4	247	182	167	GPMT140408-U	TS5	TKY25D

TAF DRILLS



Ø 32.0~38.0

CUTTING CONDITIONS



D174

DRILLING (INDEXABLE TYPE)

TAFS, TAFM, TAFL

- High rigidity holder.
- 4 corner use insert.
- Various grades and chip breakers.

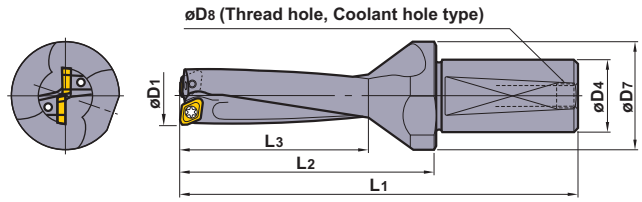

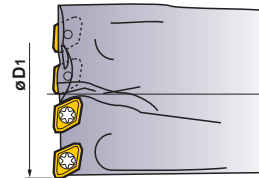

* The screw hole on the flange section is not a coolant hole.



Number of Teeth = 4 (øD1 ≥ 49)

TAF DRILLS

Drill Diameter D1 (mm)	Hole Depth (l/d)	Order Number	Stock	Number of Teeth	Dimensions (mm)						Insert Number	 Clamp Screw	 Wrench
					D4	D7	D8	L1	L2	L3			
39.0	2	TAFS3900F32	●	2	32	50	PT1/8	163	108	94	GPMT140408-U	TS55	TKY25D
	2	TAFS3900F40	●	2	40	50	PT1/4	173	108	94	GPMT140408-U	TS55	TKY25D
	3	TAFM3900F32	●	2	32	50	PT1/8	202	147	133	GPMT140408-U	TS55	TKY25D
	3	TAFM3900F40	●	2	40	50	PT1/4	212	147	133	GPMT140408-U	TS55	TKY25D
	4	TAFL3900F32	●	2	32	42	PT1/8	251	186	172	GPMT140408-U	TS5	TKY25D
	4	TAFL3900F40	●	2	40	50	PT1/4	251	186	172	GPMT140408-U	TS5	TKY25D
40.0	2	TAFS4000F32	●	2	32	50	PT1/8	165	110	96	GPMT140408-U	TS55	TKY25D
	2	TAFS4000F40	●	2	40	50	PT1/4	175	110	96	GPMT140408-U	TS55	TKY25D
	3	TAFM4000F32	●	2	32	50	PT1/8	205	150	136	GPMT140408-U	TS55	TKY25D
	3	TAFM4000F40	●	2	40	50	PT1/4	215	150	136	GPMT140408-U	TS55	TKY25D
	4	TAFL4000F32	●	2	32	42	PT1/8	245	190	176	GPMT140408-U	TS5	TKY25D
	4	TAFL4000F40	●	2	40	50	PT1/4	255	190	176	GPMT140408-U	TS5	TKY25D
41.0	2	TAFS4100F40	●	2	40	50	PT1/4	177	112	98	GPMT140408-U	TS55	TKY25D
	3	TAFM4100F40	●	2	40	50	PT1/4	218	153	139	GPMT140408-U	TS55	TKY25D
	4	TAFL4100F40	●	2	40	50	PT1/4	259	194	180	GPMT140408-U	TS5	TKY25D
42.0	2	TAFS4200F40	●	2	40	50	PT1/4	179	114	101	GPMT140408-U	TS55	TKY25D
	3	TAFM4200F40	●	2	40	50	PT1/4	221	156	143	GPMT140408-U	TS55	TKY25D
	4	TAFL4200F40	●	2	40	50	PT1/4	263	198	185	GPMT140408-U	TS5	TKY25D
43.0	2	TAFS4300F40	●	2	40	50	PT1/4	181	116	103	GPMT140408-U	TS55	TKY25D
	3	TAFM4300F40	●	2	40	50	PT1/4	224	159	146	GPMT140408-U	TS55	TKY25D
	4	TAFL4300F40	●	2	40	50	PT1/4	267	202	189	GPMT140408-U	TS5	TKY25D
44.0	2	TAFS4400F40	●	2	40	50	PT1/4	183	118	106	GPMT140408-U	TS55	TKY25D
	3	TAFM4400F40	●	2	40	50	PT1/4	227	162	150	GPMT140408-U	TS55	TKY25D
	4	TAFL4400F40	●	2	40	50	PT1/4	271	206	194	GPMT140408-U	TS5	TKY25D
45.0	2	TAFS4500F40	●	2	40	54	PT1/4	185	120	108	GPMT140408-U	TS55	TKY25D
	3	TAFM4500F40	●	2	40	54	PT1/4	230	165	153	GPMT140408-U	TS55	TKY25D
	4	TAFL4500F40	●	2	40	54	PT1/4	275	210	198	GPMT140408-U	TS5	TKY25D
46.0	2	TAFS4600F40	●	2	40	54	PT1/4	187	122	110	GPMT140408-U	TS55	TKY25D
	3	TAFM4600F40	●	2	40	54	PT1/4	233	168	156	GPMT140408-U	TS55	TKY25D
	4	TAFL4600F40	●	2	40	54	PT1/4	279	214	202	GPMT140408-U	TS5	TKY25D

- : Stock Standard
- ★ : Stock Standard in Japan.
- : Non stock, produced to order only

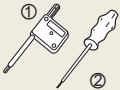
Drill Diameter D1 (mm)	Hole Depth (l/d)	Order Number	Stock	Number of Teeth	Dimensions (mm)						Insert Number		
					D4	D7	D8	L1	L2	L3			
47.0	2	TAFS4700F40	●	2	40	54	PT1/4	189	124	113	GPMT140408-U	TS55	TKY25D
	3	TAFM4700F40	●	2	40	54	PT1/4	236	171	160	GPMT140408-U	TS55	TKY25D
	4	TAFL4700F40	●	2	40	54	PT1/4	283	218	207	GPMT140408-U	TS5	TKY25D
48.0	2	TAFS4800F40	●	2	40	54	PT1/4	191	126	115	GPMT140408-U	TS55	TKY25D
	3	TAFM4800F40	●	2	40	54	PT1/4	239	174	163	GPMT140408-U	TS55	TKY25D
	4	TAFL4800F40	●	2	40	54	PT1/4	287	222	211	GPMT140408-U	TS5	TKY25D
49.0	2	TAFS4900F40	●	4	40	58	PT1/4	198	133	118	GPMT090304-U	TS3	TKY08F
	3	TAFM4900F40	●	4	40	58	PT1/4	247	182	167	GPMT090304-U	TS3	TKY08F
	4	TAFL4900F40	●	4	40	58	PT1/4	296	231	216	GPMT090304-U	TS3	TKY08F
50.0	2	TAFS5000F40	▲*	4	40	58	PT1/4	200	135	120	GPMT090304-U	TS3	TKY08F
	3	TAFM5000F40	▲*	4	40	58	PT1/4	250	185	170	GPMT090304-U	TS3	TKY08F
	4	TAFL5000F40	▲*	4	40	58	PT1/4	300	235	220	GPMT090304-U	TS3	TKY08F
51.0	2	TAFS5100F40	▲*	4	40	58	PT1/4	202	137	122	GPMT090304-U	TS3	TKY08F
	3	TAFM5100F40	▲*	4	40	58	PT1/4	253	188	173	GPMT090304-U	TS3	TKY08F
	4	TAFL5100F40	▲*	4	40	58	PT1/4	304	239	224	GPMT090304-U	TS3	TKY08F
52.0	2	TAFS5200F40	▲*	4	40	58	PT1/4	204	139	125	GPMT090304-U	TS3	TKY08F
	3	TAFM5200F40	▲*	4	40	58	PT1/4	256	191	177	GPMT090304-U	TS3	TKY08F
	4	TAFL5200F40	▲*	4	40	58	PT1/4	308	243	229	GPMT090304-U	TS3	TKY08F
53.0	2	TAFS5300F40	▲*	4	40	63	PT1/4	206	141	127	GPMT090304-U	TS3	TKY08F
	3	TAFM5300F40	▲*	4	40	63	PT1/4	259	194	180	GPMT090304-U	TS3	TKY08F
	4	TAFL5300F40	▲*	4	40	63	PT1/4	312	247	233	GPMT090304-U	TS3	TKY08F
54.0	2	TAFS5400F40	▲*	4	40	63	PT1/4	208	143	128	GPMT090304-U	TS3	TKY08F
	3	TAFM5400F40	▲*	4	40	63	PT1/4	262	197	182	GPMT090304-U	TS3	TKY08F
	4	TAFL5400F40	▲*	4	40	63	PT1/4	316	251	236	GPMT090304-U	TS3	TKY08F
55.0	2	TAFS5500F40	▲*	4	40	63	PT1/4	210	145	130	GPMT090304-U	TS3	TKY08F
	3	TAFM5500F40	▲*	4	40	63	PT1/4	265	200	185	GPMT090304-U	TS3	TKY08F
	4	TAFL5500F40	▲*	4	40	63	PT1/4	320	255	240	GPMT090304-U	TS3	TKY08F
56.0	2	TAFS5600F40	▲*	4	40	63	PT1/4	212	147	132	GPMT090304-U	TS3	TKY08F
	3	TAFM5600F40	▲*	4	40	63	PT1/4	268	203	188	GPMT090304-U	TS3	TKY08F
	4	TAFL5600F40	▲*	4	40	63	PT1/4	324	259	244	GPMT090304-U	TS3	TKY08F

(Note) * Items with an asterisk (*) will be replaced by the products on page D172 (TAF-E).

DRILLING (INDEXABLE TYPE)

TAFS, TAFM, TAFL

- High rigidity holder.
- 4 corner use insert.
- Various grades and chip breakers.



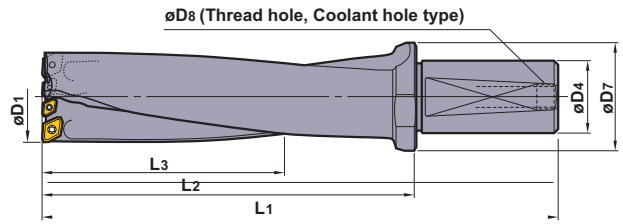
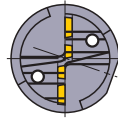

● Increased Rigidity Type

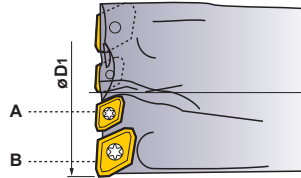

* The screw hole on the flange section is not a coolant hole.



DRILLING TAF DRILLS

Drill Diameter D1 (mm)	Hole Depth (l/d)	Order Number	Stock	Number of Teeth	Dimensions (mm)						Inner / Outer type	Insert Number	 Clamp Screw	 Wrench
					D4	D7	D8	L1	L2	L3				
50.0	2	TAFS5000F40-E	●	4	40	58	PT1/4	200	135	120	A	GPMT090304-U	TS3	①TKY08F
		GPMT11T308-U	TS4	②TKY15D										
	3	TAFM5000F40-E	●	4	40	58	PT1/4	250	185	170	A	GPMT090304-U	TS3	①TKY08F
		GPMT11T308-U	TS4	②TKY15D										
	4	TAFS5000F40-E	●	4	40	58	PT1/4	300	235	220	A	GPMT090304-U	TS3	①TKY08F
		GPMT11T308-U	TS4	②TKY15D										
51.0	2	TAFS5100F40-E	●	4	40	58	PT1/4	202	137	122	A	GPMT090304-U	TS3	①TKY08F
		GPMT11T308-U	TS4	②TKY15D										
	3	TAFM5100F40-E	●	4	40	58	PT1/4	253	188	173	A	GPMT090304-U	TS3	①TKY08F
		GPMT11T308-U	TS4	②TKY15D										
	4	TAFS5100F40-E	●	4	40	58	PT1/4	304	239	224	A	GPMT090304-U	TS3	①TKY08F
		GPMT11T308-U	TS4	②TKY15D										
52.0	2	TAFS5200F40-E	●	4	40	58	PT1/4	204	139	125	A	GPMT090304-U	TS3	①TKY08F
		GPMT11T308-U	TS4	②TKY15D										
	3	TAFM5200F40-E	●	4	40	58	PT1/4	256	191	177	A	GPMT090304-U	TS3	①TKY08F
		GPMT11T308-U	TS4	②TKY15D										
	4	TAFS5200F40-E	●	4	40	58	PT1/4	308	243	229	A	GPMT090304-U	TS3	①TKY08F
		GPMT11T308-U	TS4	②TKY15D										
53.0	2	TAFS5300F40-E	●	4	40	63	PT1/4	206	141	127	A	GPMT11T308-U	TS4	②TKY15D
	3	TAFM5300F40-E	●	4	40	63	PT1/4	259	194	180	A	GPMT11T308-U	TS4	②TKY15D
	4	TAFS5300F40-E	●	4	40	63	PT1/4	312	247	233	A	GPMT11T308-U	TS4	②TKY15D
54.0	2	TAFS5400F40-E	●	4	40	63	PT1/4	208	134	128	A	GPMT11T308-U	TS4	②TKY15D
	3	TAFM5400F40-E	●	4	40	63	PT1/4	262	197	182	A	GPMT11T308-U	TS4	②TKY15D
	4	TAFS5400F40-E	●	4	40	63	PT1/4	316	251	236	A	GPMT11T308-U	TS4	②TKY15D
55.0	2	TAFS5500F40-E	●	4	40	63	PT1/4	210	145	130	A	GPMT11T308-U	TS4	②TKY15D
	3	TAFM5500F40-E	●	4	40	63	PT1/4	265	200	185	A	GPMT11T308-U	TS4	②TKY15D
	4	TAFS5500F40-E	●	4	40	63	PT1/4	320	255	240	A	GPMT11T308-U	TS4	②TKY15D
56.0	2	TAFS5600F40-E	●	4	40	63	PT1/4	212	147	132	A	GPMT11T308-U	TS4	②TKY15D
	3	TAFM5600F40-E	●	4	40	63	PT1/4	268	203	188	A	GPMT11T308-U	TS4	②TKY15D
	4	TAFS5600F40-E	●	4	40	63	PT1/4	324	259	244	A	GPMT11T308-U	TS4	②TKY15D

- : Stock Standard
- ★ : Stock Standard in Japan.
- : Non stock, produced to order only

INSERTS

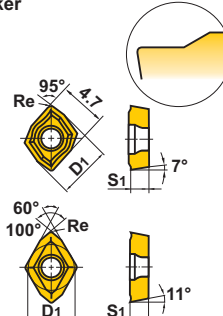
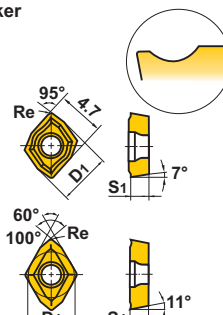
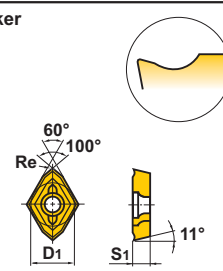
Geometry	Drill Dia.	Insert Number	Dimensions (mm)			Stock					
			D1	S1	Re	VP15TF	UP20M	GP20M	UE6020	US735	F5010
U1 Breaker 	ø12-ø14.5	GCMT040204-U1	5.0	2.38	0.4		●				
	ø15-ø17.5	GPMT060204-U1	5.56	2.38	0.4		●		●	●	●
	ø18-ø22.5	GPMT070204-U1	6.35	2.38	0.4		●		●	●	●
	ø23-ø27.5 ø49-ø56	GPMT090304-U1	7.94	3.18	0.4		●		●	●	●
	ø28-ø34	GPMT11T308-U1	9.525	3.97	0.8		●		●	●	●
	ø35-ø48	GPMT140408-U1	12.70	4.76	0.8		●		●	●	●
U2 Breaker 	ø12-ø14.5	GCMT040204-U2	5.0	2.38	0.4	●		●			
	ø15-ø17.5	GPMT060204-U2	5.56	2.38	0.4	●	●		●	●	●
	ø18-ø22.5	GPMT070204-U2	6.35	2.38	0.4	●	●		●	●	●
	ø23-ø27.5 ø49-ø56	GPMT090304-U2	7.94	3.18	0.4	●	●		●	●	●
	ø28-ø34	GPMT11T308-U2	9.525	3.97	0.8	●	●		●	●	●
	ø35-ø48	GPMT140408-U2	12.70	4.76	0.8	●	●		●	●	●
U3 Breaker 	ø15-ø17.5	GPMT060204-U3	5.56	2.38	0.4		●		●	●	●
	ø18-ø22.5	GPMT070204-U3	6.35	2.38	0.4		●		●	●	●
	ø23-ø27.5 ø49-ø56	GPMT090304-U3	7.94	3.18	0.4		●		●	●	●
	ø28-ø34	GPMT11T308-U3	9.525	3.97	0.8		●		●	●	●
	ø35-ø48	GPMT140408-U3	12.70	4.76	0.8		●		●	●	●

INSERT RECOMMENDATION

CHIP BREAKER RECOMMENDATION

◎ : 1st Recommendation ○ : 2nd Recommendation

Work Material	P						M		K			
	Mild Steel		Carbon Steel		Alloy Steel		Stainless Steel		Cast Iron		Ductile Cast Iron	
	GCMT	GPMT	GCMT	GPMT	GCMT	GPMT	GCMT	GPMT	GCMT	GPMT	GCMT	GPMT
Breaker												
U1	◎	◎	○	○	○	○	○	○	○	○	○	○
U2	○	○	◎	◎	◎	◎	◎	◎	◎	○	◎	○
U3		○		◎		◎		○		◎		◎

INSERT GRADE RECOMMENDATION

◎ : 1st Recommendation ○ : 2nd Recommendation

Work Material	P						M		K			
	Mild Steel		Carbon Steel		Alloy Steel		Stainless Steel		Cast Iron		Ductile Cast Iron	
	GCMT	GPMT	GCMT	GPMT	GCMT	GPMT	GCMT	GPMT	GCMT	GPMT	GCMT	GPMT
VP15TF	○	○	◎	○	◎	○	◎	◎	◎	○	◎	○
UP20M	◎	◎	○	○	○	○	○	○	○	○	○	◎
GP20M	○		◎		◎		◎		◎		◎	
UE6020		○		◎		◎		○		○		○
US735		○		○		○		◎		○		○
F5010										◎		◎

RECOMMENDED CUTTING CONDITIONS

Work Material	Hardness	Cutting Speed (m/min)			Breaker	Feed (mm/rev)					
		For l/d=2, 3		For l/d=4		Drill Diameter (mm)					
		($\phi 12-\phi 14.5$)	($\phi 15-$)	($\phi 16-$)		$\phi 12-\phi 14.5$	$\phi 15-\phi 22.5$	$\phi 23-\phi 34$	$\phi 35-\phi 48$	$\phi 49-\phi 56$	
P Mild Steel	$\leq 180\text{HB}$	150 (100-200)	200 (150-300)	140 (100-200)	U1	0.06 (0.04-0.10)	0.07 (0.04-0.10)	0.08 (0.04-0.10)	0.10 (0.04-0.12)	0.08 (0.04-0.10)	
					U2	0.06 (0.04-0.10)	0.08 (0.04-0.12)	0.10 (0.04-0.12)	0.12 (0.04-0.14)	0.10 (0.04-0.12)	
					U3	-	0.08 (0.04-0.12)	0.10 (0.04-0.12)	0.12 (0.04-0.14)	0.10 (0.04-0.12)	
	Carbon Steel	180-280HB	120 (80-160)	150 (120-180)	100 (80-120)	U1	0.06 (0.04-0.10)	0.09 (0.06-0.12)	0.12 (0.08-0.14)	0.15 (0.08-0.18)	0.12 (0.08-0.14)
						U2	0.06 (0.04-0.10)	0.12 (0.06-0.14)	0.14 (0.08-0.18)	0.17 (0.08-0.20)	0.14 (0.08-0.18)
						U3	-	0.12 (0.06-0.14)	0.14 (0.08-0.18)	0.17 (0.08-0.20)	0.14 (0.08-0.18)
	Alloy Steel	180-280HB	120 (80-160)	150 (120-180)	100 (80-120)	U1	0.06 (0.04-0.10)	0.08 (0.06-0.10)	0.09 (0.06-0.12)	0.11 (0.06-0.14)	0.09 (0.06-0.12)
						U2	0.06 (0.04-0.10)	0.10 (0.06-0.12)	0.12 (0.08-0.16)	0.14 (0.08-0.18)	0.12 (0.08-0.16)
						U3	-	0.10 (0.06-0.12)	0.12 (0.08-0.16)	0.14 (0.08-0.18)	0.12 (0.08-0.16)
M Stainless Steel	$\leq 200\text{HB}$	100 (80-120)	150 (120-200)	110 (80-140)	U1	0.07 (0.04-0.10)	0.07 (0.04-0.10)	0.08 (0.04-0.10)	0.10 (0.04-0.12)	0.08 (0.04-0.10)	
					U2	0.07 (0.04-0.10)	0.08 (0.04-0.12)	0.10 (0.04-0.14)	0.12 (0.04-0.16)	0.10 (0.04-0.14)	
					U3	-	0.08 (0.04-0.12)	0.10 (0.04-0.14)	0.12 (0.04-0.16)	0.10 (0.04-0.14)	
K Cast Iron	Tensile Strength $\leq 350\text{N/mm}^2$	120 (80-160)	150 (120-180)	140 (110-160)	U1	0.07 (0.06-0.10)	0.07 (0.06-0.10)	0.10 (0.04-0.14)	0.10 (0.06-0.14)	0.10 (0.06-0.14)	
					U2	0.07 (0.06-0.10)	0.15 (0.10-0.18)	0.20 (0.10-0.25)	0.20 (0.10-0.25)	0.20 (0.10-0.25)	
					U3	-	0.15 (0.10-0.18)	0.20 (0.10-0.25)	0.20 (0.10-0.25)	0.20 (0.10-0.25)	
Ductile Cast Iron	Tensile Strength $\leq 450\text{N/mm}^2$	120 (80-150)	150 (120-180)	100 (80-120)	U1	0.06 (0.04-0.10)	0.07 (0.06-0.10)	0.10 (0.06-0.14)	0.10 (0.06-0.14)	0.10 (0.06-0.14)	
					U2	0.06 (0.04-0.10)	0.12 (0.08-0.14)	0.15 (0.08-0.20)	0.18 (0.08-0.20)	0.15 (0.08-0.20)	
					U3	-	0.12 (0.08-0.14)	0.15 (0.08-0.20)	0.18 (0.08-0.20)	0.15 (0.08-0.20)	

(Note) When using drills for l/d= 4, the feed should be reduced to 80% of the above recommendations.

CUTTING RESISTANCE

Workpiece : DIN X5CrNi189 (220HB) Cutting Speed : 150m/min Insert : U2 Breaker

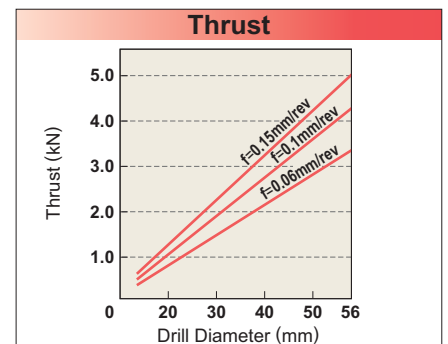
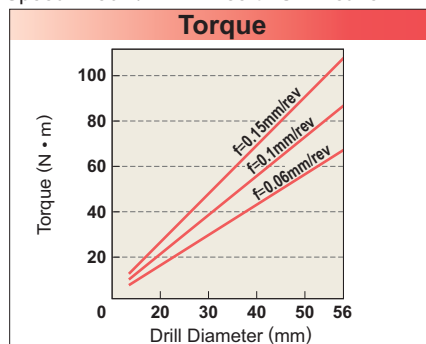
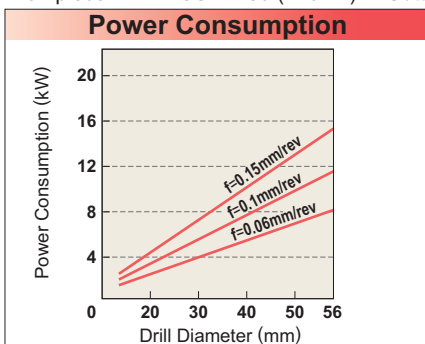

APPLICATIONS

● Angled face drilling

Workpiece : DIN 42Cr Mo4 (180HB - 280HB)
 Drill $\phi 20$ (3D type), Cutting speed : 80m/min
 Feed : 0.08mm/rev

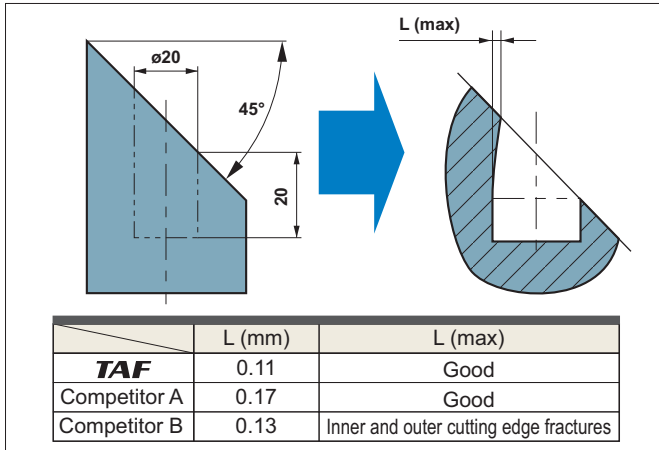

● Round workpiece drilling

Workpiece : DIN 42Cr Mo4 (180HB - 280HB)
 Drill $\phi 20$ (3D type), Cutting speed : 50, 80, 100m/min
 Feed : 0.08mm/rev (initial cutting 0.05mm/rev)

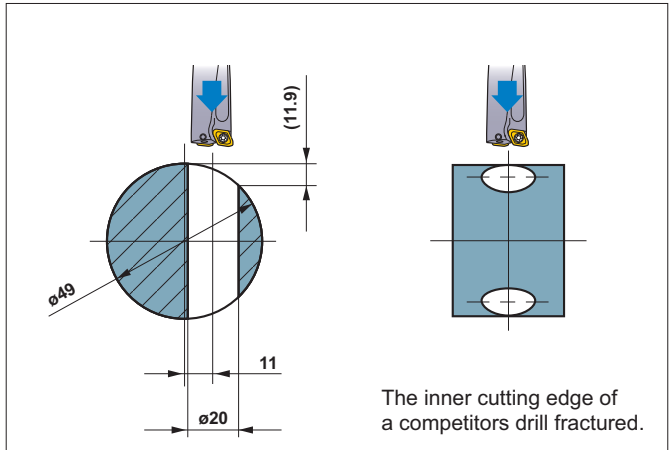

● Open sided drilling

Workpiece : JIS S50C (120HB - 180HB), Drill $\phi 20$ (3D type), Cutting speed : 80m/min Feed : 0.08mm/rev

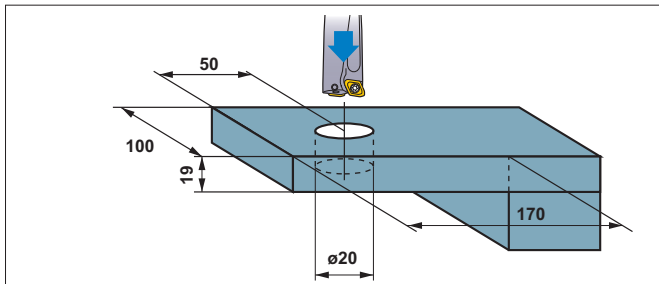

● Drill oversize (to measured drill diameter)

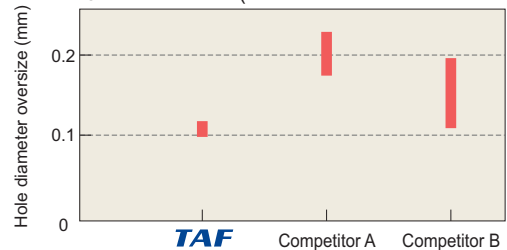

● Please ensure the highest rigidity possible exists in both machine set up and workholding.

● Refer to the following graph for coolant pressure and volume. Coolant is an important factor in the efficient use of these drills.

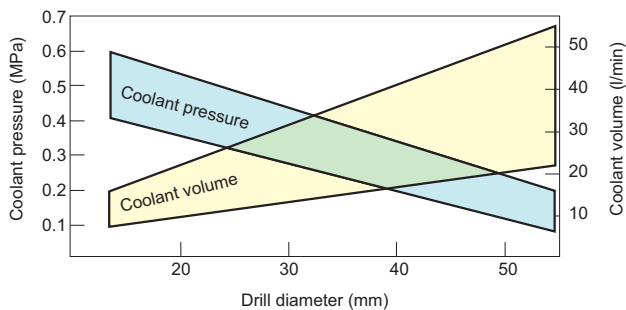

● Cannot be used for stack drilling.
 In common with many indexable insert drills, these drills produce a round disc on exit which unless evacuated may cause the drill to fracture.

● Use on a lathe

(1) The inner cutting edge must be positioned between 0-0.2mm over center.

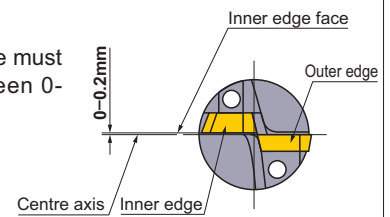

(2) To adjust the hole diameter by off-setting the drill, the outer cutting edge and machine axis must be set parallel.

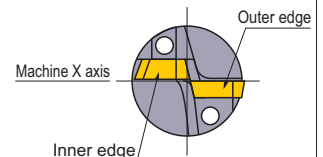

(3) When producing an oversize hole. The drill offset should be no more than 2% of the diameter. It is not possible to produce an undersized hole.

(4) When through hole drilling on a lathe the disc produced by the drill exiting the workpiece may be expelled at high velocity. To reduce the danger of injury or damage a cover guard is highly recommended.

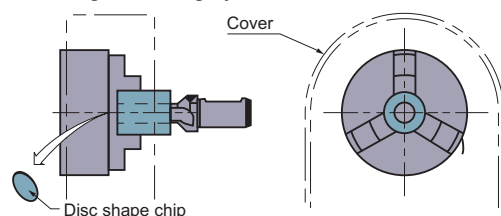

JUST FIT SLEEVE

- A sleeve designed to improve the versatility of the TAF drills, allowing the cutting diameter to be increased in increments of 0.1mm

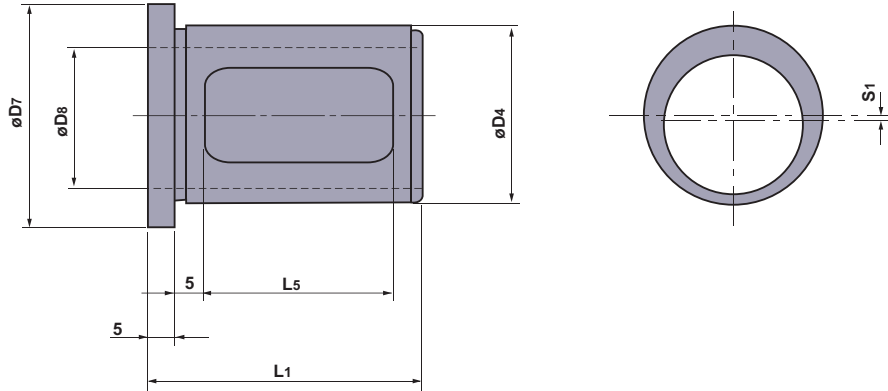

* Increase : Size of the increase in the cutting diameter.

Set Order Number	Individual Order Number	Stock	Dimensions (mm)					*Increase (S ₁ ×2)	Suitable TAF Type Drill
			D7	D4	D8	L1	L5		
JFS-1	JFS2520-10	●	33	25	20	43	30	0.10	TAFS/M/L1200F20 TAFS/M/L1550F20
	2520-20	●	33	25	20	43	30	0.20	
	2520-30	●	33	25	20	43	30	0.30	
	2520-40	●	33	25	20	43	30	0.40	
	2520-50	●	33	25	20	43	30	0.50	
JFS-2	JFS3225-10	●	40	32	25	50	34	0.10	TAFS/M/L1600F25 TAFS/M/L2450F25
	3225-20	●	40	32	25	50	34	0.20	
	3225-30	●	40	32	25	50	34	0.30	
	3225-40	●	40	32	25	50	34	0.40	
	3225-50	●	40	32	25	50	34	0.50	
JFS-3	JFS4032-10	●	48	40	32	55	40	0.10	TAFS/M/L2500F32 TAFS/M/L2950F32
	4032-20	●	48	40	32	55	40	0.20	
	4032-30	●	48	40	32	55	40	0.30	
	4032-40	●	48	40	32	55	40	0.40	
	4032-50	●	48	40	32	55	40	0.50	

JFS JUST FIT SLEEVE

DRILLING

JFS

GUIDELINE FOR SELECTING A JUST FIT SLEEVE

Desired = (Drill ϕ + Increase of JFS) + 0.1mm

(Eg.) Desired diameter is 20.3mm (oversize is taken as 0.1mm).

$$\phi 20.3 = (\text{TAFS/M/L2000F25} + \text{JFS3225-20}) + 0.1$$

20mm Drill

Using JFS an Increase of 0.2mm.

Oversize

<Tool Selected>
TAF Drill : TAFM2000F25
Just Fit Sleeve [JFS]
: JFS3225-20

(Note) Oversize can vary due to the cutting conditions used, please use the above as a guideline.

ORDERING THE JUST FIT SLEEVE

●Purchasing Method 1

Oversize can vary due to the cutting conditions used. Therefore it is recommended to purchase as a set. When placing an order, please use the Set order number. (5 sleeves/set)

●Purchasing Method 2

It is possible to order individually. When placing an order, please use the individual order number.

- : Stock Standard
- ★ : Stock Standard in Japan.
- : Non stock, produced to order only

APPLICATIONS

APPLICATION OF THE JUST FIT SLEEVE

1 When inserting the drill into the side lock holder, align the V groove on the outer peripheral edge of the drill flange, the round holes of the outer peripheral edge of the sleeve flange and the screws of the side lock holder for fixing the drill. (If the drill does not have a V groove, align the notch of the drill shank with the round holes of the sleeve.)

2 Insert screws A of the side lock holder directly through the open window of the sleeve to clamp the drill. Tighten screw B only to a degree that does not damage the sleeve.

(Note)

- Fine adjustments cannot be made for the diameter of the sleeve.
- Cannot be used with collect chuck type holders.

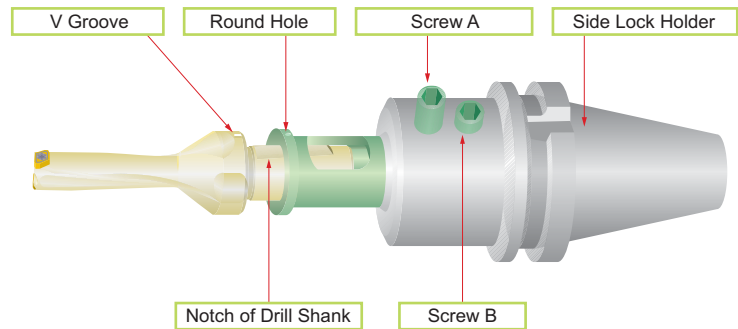

BRA, BRS,
BRK, BRM

Brazed drill with excellent cutting sharpness
and chip disposal properties.
Suitable for stainless, mild and
general steel drilling.



PRECISION
FOR SUCCESS

CHOOSE JAPAN'S NO. 1

MITSUBISHI
MITSUBISHI MATERIALS

www.mitsubishicarbide.com

DRILLING (BRAZED TYPE)

BRA

- Low thrust due to the absence of a chisel edge.
- Easy regrinding.



P	M	K	S	N	H
✓	✓	✓			

(l/d=3)

D1(h7)	6.0<D1≤10.0	10.0<D1≤18.0	18.0<D1≤30.0
Tolerance	0 -0.015	0 -0.018	0 -0.021

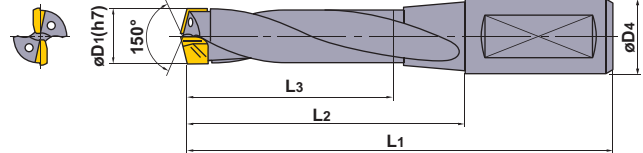

● General Use (Carbon Steel, Alloy Steel, Stainless Steel)

Drill Dia. D1 (mm)	Standard Diameter		Intermediate Diameters		Dimensions (mm)				
	Order Number	Stock UP20M	Range of Drill Diameters (D1)	Order Number	D4	L1	L2	L3	
8.0	BRA0800S16	●	8.0<D1≤8.5	BRA□□□□S16	16	83	35	23	
8.5	0850S16	●			16	83	35	23	
9.0	0900S16	●			8.5<D1≤9.5	16	88	40	28
9.5	0950S16	●				16	88	40	28
10.0	1000S16	●			9.5<D1≤10.5	16	93	45	35
10.5	1050S16	●				16	93	45	35
11.0	1100S16	●			10.5<D1≤11.5	16	99	51	40
11.5	1150S16	●				16	99	51	40
12.0	1200S16	●			11.5<D1≤12.5	16	104	56	44
12.5	1250S16	●				16	104	56	44
13.0	1300S16	●			12.5<D1≤13.5	16	109	61	48
13.5	1350S16	●				16	109	61	48
14.0	1400S16	●			13.5<D1≤14.5	16	114	66	52
14.5	1450S16	●	16	114		66	52		
15.0	1500S20	●	14.5<D1≤15.5	BRA□□□□S20	20	126	76	61	
15.5	1550S20	●			20	126	76	61	
16.0	1600S20	●			15.5<D1≤16.5	20	131	81	65
16.5	1650S20	●				20	131	81	65
17.0	1700S20	●			16.5<D1≤17.5	20	136	86	69
17.5	1750S20	●				20	136	86	69
18.0	1800S20	●			17.5<D1≤18.5	20	141	91	73
18.5	1850S20	●				20	141	91	73
19.0	1900S25	●	18.5<D1≤19.5	BRA□□□□S25	25	157	101	77	
19.5	1950S25	●			25	157	101	77	
20.0	2000S25	●			19.5<D1≤20.5	25	157	101	81
20.5	2050S25	●				25	157	101	81
21.0	2100S25	●			20.5<D1≤21.5	25	157	101	80
21.5	2150S25	●				25	157	101	80
22.0	2200S25	●			21.5<D1≤22.5	25	162	106	84
22.5	2250S25	●	25	162		106	84		

BRA DRILLS

DRILLING
Ø 8.0 ~ 22.5

- : Stock Standard
- ★ : Stock Standard in Japan.
- : Non stock, produced to order only

CUTTING CONDITIONS



D184

DRILLING (BRAZED TYPE)

BRA

- Low thrust due to the absence of a chisel edge.
- Easy regrinding.



P ✓	M ✓	K ✓	S	N	H
------------	------------	------------	----------	----------	----------

(l/d=3)

D1(h7)	6.0<D1≤10.0	10.0<D1≤18.0	18.0<D1≤30.0
Tolerance	0 -0.015	0 -0.018	0 -0.021

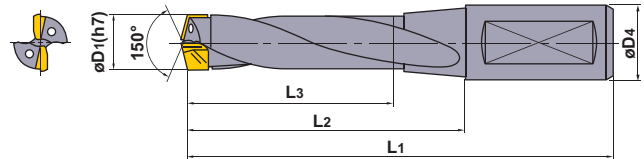

● General Use (Carbon Steel, Alloy Steel, Stainless Steel)

Drill Dia. D1 (mm)	Standard Diameter		Intermediate Diameters		Dimensions (mm)			
	Order Number	Stock UP20M	Range of Drill Diameters (D1)	Order Number	D4	L1	L2	L3
23.0	BRA2300S25	●	22.5<D1≤23.5	BRA□□□□S25	25	162	106	83
23.5	2350S25	●			25	162	106	83
24.0	2400S32	●	23.5<D1≤24.5	BRA□□□□S32	32	171	111	87
24.5	2450S32	●			32	171	111	87
25.0	2500S32	●	24.5<D1≤25.5		32	171	111	86
25.5	2550S32	●			32	171	111	86
26.0	2600S32	●	25.5<D1≤26.5		32	176	116	90
26.5	2650S32	●			32	176	116	90
27.0	2700S32	●	26.5<D1≤27.5		32	176	116	89
27.5	2750S32	●			32	176	116	89
28.0	2800S32	●	27.5<D1≤28.5		32	181	121	93
28.5	2850S32	●			32	181	121	93
29.0	2900S32	●	28.5<D1≤29.5	32	186	126	97	
29.5	2950S32	●		32	186	126	97	
30.0	3000S32	●	29.5<D1≤30.5	32	186	126	96	
30.5	3050S32	●		32	186	126	96	
31.0	3100S40	□	30.5<D1≤31.5	BRA□□□□S40	40	197	127	96
31.5	3150S40	□			40	197	127	96
32.0	3200S40	□	31.5<D1≤32.5		40	202	132	100
32.5	3250S40	□			40	202	132	100
33.0	3300S40	□	32.5<D1≤33.5		40	207	137	104
33.5	3350S40	□			40	207	137	104
34.0	3400S40	□	33.5<D1≤34.5		40	207	137	103
34.5	3450S40	□			40	207	137	103
35.0	3500S40	□	34.5<D1≤35.5		40	212	142	107
35.5	3550S40	□			40	212	142	107
36.0	3600S40	□	35.5<D1≤36.5	40	217	147	111	
36.5	3650S40	□		40	217	147	111	
37.0	3700S40	□	36.5<D1≤37.5	40	222	152	115	
37.5	3750S40	□		40	222	152	115	
38.0	3800S40	□	37.5<D1≤38.5	40	227	157	119	
38.5	3850S40	□		40	227	157	119	
39.0	3900S40	□	38.5<D1≤39.5	40	227	157	118	
39.5	3950S40	□		40	227	157	118	
40.0	4000S40	□	39.5<D1≤40.0	40	232	162	122	

(Note 1) Standard drills are for clockwise rotation only.

(Note 2) Drills in the drill diameter range column are produced to order only.

(Note 3) For ordering an intermediate diameter, please enter the diameter (D1) into the 4-digit space □□□□ in the nominal designation.

(Ex. UP20M BRA2[5][3][0]S32 for a diameter of φ25.30mm)

(Note 4) Please contact us regarding special designs that are not standard products.

- : Stock Standard
- ★ : Stock Standard in Japan.
- : Non stock, produced to order only



DRILLING (BRAZED TYPE)

BRS

- Excellent cutting sharpness and chip discharge due to high rake type insert.
- High efficiency, high accuracy machining.
- Suitable for stainless steel, mild steel and general steel drilling. (l/d=3)



P ✓	M ✓	K ✓	S	N	H
------------	------------	------------	----------	----------	----------

(l/d=3)

D1(h7)	10.0 < D1 ≤ 8.0	18.0 < D1 ≤ 30.0
Tolerance	0 -0.018	0 -0.021

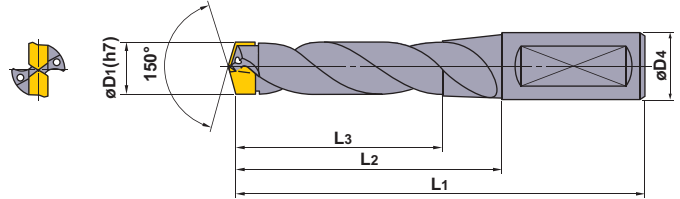

Drill Dia. D1 (mm)	Standard Diameter		Intermediate Diameters		Dimensions (mm)				
	Order Number	Stock UP20M	Range of Drill Diameters (D1)	Order Number	D4	L1	L2	L3	
14.0	BRS1400S16	●	14.0 < D1 ≤ 14.5	BRS□□□□S16	16	114	66	52	
14.5	1450S16	●			16	114	66	52	
15.0	1500S20	●	14.5 < D1 ≤ 15.5	BRS□□□□S20	20	126	76	61	
15.5	1550S20	●			20	126	76	61	
16.0	1600S20	●	15.5 < D1 ≤ 16.5		20	131	81	65	
16.5	1650S20	●			20	131	81	65	
17.0	1700S20	●	16.5 < D1 ≤ 17.5		20	136	86	69	
17.5	1750S20	●			20	136	86	69	
18.0	1800S20	●	17.5 < D1 ≤ 18.5		20	141	91	73	
18.5	1850S20	●			20	141	91	73	
19.0	1900S25	●	18.5 < D1 ≤ 19.5		BRS□□□□S25	25	157	101	77
19.5	1950S25	●				25	157	101	77
20.0	2000S25	●	19.5 < D1 ≤ 20.5	25		157	101	81	
20.5	2050S25	●		25		157	101	81	
21.0	2100S25	●	20.5 < D1 ≤ 21.5	25		157	101	80	
21.5	2150S25	●		25		157	101	80	
22.0	2200S25	●	21.5 < D1 ≤ 22.5	25		162	106	84	
22.5	2250S25	●		25		162	106	84	
23.0	2300S25	●	22.5 < D1 ≤ 23.5	25		162	106	83	
23.5	2350S25	●		25		162	106	83	
24.0	2400S32	●	23.5 < D1 ≤ 24.5	BRS□□□□S32		32	171	111	87
24.5	2450S32	●				32	171	111	87
25.0	2500S32	●	24.5 < D1 ≤ 25.5		32	171	111	86	
25.5	2550S32	●			32	171	111	86	
26.0	2600S32	●	25.5 < D1 ≤ 26.5		32	176	116	90	
26.5	2650S32	●			32	176	116	90	
27.0	2700S32	●	26.5 < D1 ≤ 27.5		32	176	116	89	
27.5	2750S32	●			32	176	116	89	
28.0	2800S32	●	27.5 < D1 ≤ 28.5		32	181	121	93	
28.5	2850S32	●			32	181	121	93	
29.0	2900S32	●	28.5 < D1 ≤ 29.5		32	186	126	97	
29.5	2950S32	●			32	186	126	97	
30.0	3000S32	●	29.5 < D1 ≤ 30.5		32	186	126	96	

BRS DRILLS



For ordering an intermediate diameter, please enter the diameter (D1) into the 4-digit space □□□□ in the nominal designation.
(Ex. UP20M BRS□2530□S32 for a diameter of Ø25.30mm)

CUTTING CONDITIONS



D181

DRILLING (BRAZED TYPE)

BRM

- Excellent cutting sharpness and chip discharge due to high rake type insert.
- High efficiency, high accuracy machining.
- Suitable for stainless steel, mild steel and general steel drilling. (l/d=5)



P ✓	M ✓	K ✓	S	N	H
------------	------------	------------	----------	----------	----------

(l/d=3)

D1(h8)	10.0 < D1 ≤ 18.0	18.0 < D1 ≤ 30.0
Tolerance	0 -0.027	0 -0.033

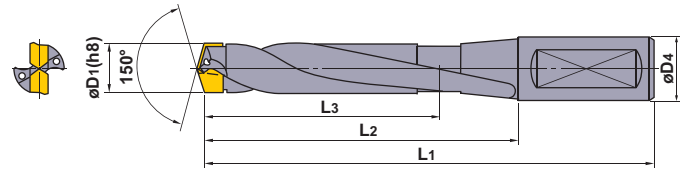

BRM DRILLS

Drill Dia. D1 (mm)	Standard Diameter		Intermediate Diameters		Dimensions (mm)			
	Order Number	Stock UP20M	Range of Drill Diameters (D1)	Order Number	D4	L1	L2	L3
14.0	BRM1400S16	●	14.0 ≤ D1 ≤ 14.5	BRM□□□□S16	16	140	92	78
14.5	1450S16	●			16	140	92	78
15.0	1500S20	●	14.5 < D1 ≤ 15.5	BRM□□□□S20	20	150	100	85
15.5	1550S20	●			20	150	100	85
16.0	1600S20	●	15.5 < D1 ≤ 16.5		20	155	105	89
16.5	1650S20	●			20	155	105	89
17.0	1700S20	●	16.5 < D1 ≤ 17.5		20	165	115	98
17.5	1750S20	●			20	165	115	98
18.0	1800S20	●	17.5 < D1 ≤ 18.5		20	170	120	102
18.5	1850S20	●			20	170	120	102
19.0	1900S25	●	18.5 < D1 ≤ 19.5	BRM□□□□S25	25	180	124	105
19.5	1950S25	●			25	180	124	105
20.0	2000S25	●	19.5 < D1 ≤ 20.5		25	190	134	114
20.5	2050S25	●			25	190	134	114
21.0	2100S25	●	20.5 < D1 ≤ 21.5		25	195	139	118
21.5	2150S25	●			25	195	139	118
22.0	2200S25	●	21.5 < D1 ≤ 22.5		25	200	144	122
22.5	2250S25	●			25	200	144	122
23.0	2300S25	●	22.5 < D1 ≤ 23.5		25	205	149	126
23.5	2350S25	●			25	205	149	126
24.0	2400S32	●	23.5 < D1 ≤ 24.5	BRM□□□□S32	32	220	160	136
24.5	2450S32	●			32	220	160	136
25.0	2500S32	●	24.5 < D1 ≤ 25.5		32	225	165	140
25.5	2550S32	●			32	225	165	140
26.0	2600S32	●	25.5 < D1 ≤ 26.5		32	230	170	144
26.5	2650S32	●			32	230	170	144
27.0	2700S32	●	26.5 < D1 ≤ 27.5		32	235	175	148
27.5	2750S32	●			32	235	175	148
28.0	2800S32	●	27.5 < D1 ≤ 28.5		32	245	185	157
28.5	2850S32	●			32	245	185	157
29.0	2900S32	●	28.5 < D1 ≤ 29.5		32	250	190	161
29.5	2950S32	●			32	250	190	161
30.0	3000S32	●	29.5 < D1 ≤ 30.0		32	255	195	165

For ordering an intermediate diameter, please enter the diameter (D1) into the 4-digit space □□□□ in the nominal designation.
(Ex. UP20M BRM2□5□3□0S32 for a diameter of φ25.30mm)

- : Stock Standard
- ★ : Stock Standard in Japan.
- : Non stock, produced to order only

DRILLING (BRAZED TYPE)

BRK

- Excellent cutting sharpness and chip discharge due to high rake type insert.
- High efficiency, high accuracy machining.
- Suitable for stainless steel, mild steel and general steel drilling. (l/d=7)



P ✓	M	K ✓	S	N	H
------------	----------	------------	----------	----------	----------

(l/d=7)

D1(h8)	10.0 < D1 ≤ 18.0	18.0 < D1 ≤ 30.0
Tolerance	$\begin{matrix} 0 \\ -0.027 \end{matrix}$	$\begin{matrix} 0 \\ -0.033 \end{matrix}$

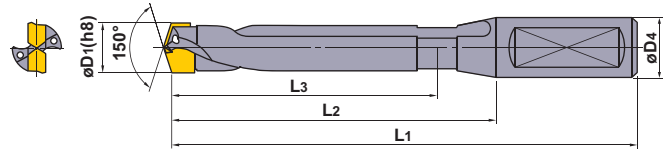

Drill Dia. D1 (mm)	Standard Diameter		Intermediate Diameters		Dimensions (mm)			
	Order Number	Stock UP20M	Range of Drill Diameters (D1)	Order Number	D4	L1	L2	L3
14.0	BRK1400S16	●	14.0 ≤ D1 ≤ 14.5	BRK□□□S16	16	174	126	112
15.0	1500S20	●	14.5 < D1 ≤ 15.5	BRK□□□S20	20	185	135	120
16.0	1600S20	●	15.5 < D1 ≤ 16.5		20	194	144	128
17.0	1700S20	●	16.5 < D1 ≤ 17.5		20	203	153	136
18.0	1800S20	●	17.5 < D1 ≤ 18.5		20	212	162	144
19.0	1900S25	●	18.5 < D1 ≤ 19.5	BRK□□□S25	25	227	171	152
20.0	2000S25	●	19.5 < D1 ≤ 20.5		25	236	180	160
21.0	2100S25	●	20.5 < D1 ≤ 21.5		25	245	189	168
22.0	2200S25	●	21.5 < D1 ≤ 22.5		25	254	198	176
23.0	2300S25	●	22.5 < D1 ≤ 23.5		25	263	207	184
24.0	2400S32	●	23.5 < D1 ≤ 24.5		BRK□□□S32	32	276	216
25.0	2500S32	●	24.5 < D1 ≤ 25.5	32		285	225	200
26.0	2600S32	●	25.5 < D1 ≤ 26.5	32		294	234	208
27.0	2700S32	●	26.5 < D1 ≤ 27.5	32		303	243	216
28.0	2800S32	●	27.5 < D1 ≤ 28.5	32		312	252	224
29.0	2900S32	●	28.5 < D1 ≤ 29.5	32		321	261	232
30.0	3000S32	●	29.5 < D1 ≤ 30.5	32		330	270	240

For ordering an intermediate diameter, please enter the diameter (D1) into the 4-digit space □□□□ in the nominal designation.
 (Ex. UP20M BRK215310S32 for a diameter of φ25.30mm)

BRK DRILLS



BRA, BRS, BRM, BRK



● BRA (l/d=3)

Work Material	Hardness	Drill Dia. $\phi 8.0 - \phi 13.0$		Drill Dia. $\phi 13.0 - \phi 18.0$		Drill Dia. $\geq \phi 18.0$	
		Cutting Speed (m/min)	Feed (mm/rev)	Cutting Speed (m/min)	Feed (mm/rev)	Cutting Speed (m/min)	Feed (mm/rev)
P Mild Steel	$\leq 180\text{HB}$	55 (40-65)	0.25 (0.20-0.30)	65 (50-75)	0.30 (0.25-0.35)	75 (60-85)	0.30 (0.25-0.35)
	180-280HB	50 (35-60)	0.25 (0.20-0.30)	60 (45-70)	0.30 (0.25-0.35)	70 (55-80)	0.30 (0.25-0.35)
	280-350HB	40 (30-50)	0.25 (0.20-0.30)	50 (40-60)	0.25 (0.20-0.30)	55 (45-65)	0.27 (0.20-0.30)
M Stainless Steel	$\leq 200\text{HB}$	30 (20-40)	0.25 (0.20-0.27)	35 (25-45)	0.27 (0.20-0.30)	40 (30-50)	0.30 (0.25-0.35)
K Cast Iron	Tensile Strength $\leq 350\text{N/mm}^2$	60 (40-70)	0.30 (0.25-0.35)	70 (50-80)	0.35 (0.30-0.40)	80 (60-90)	0.40 (0.35-0.45)
	Tensile Strength $\leq 450\text{N/mm}^2$	55 (40-65)	0.27 (0.20-0.30)	60 (45-70)	0.30 (0.25-0.35)	70 (55-80)	0.30 (0.25-0.35)
S Heat Resistant Alloy	-	15 (10-20)	0.10 (0.05-0.12)	20 (15-25)	0.15 (0.10-0.20)	25 (20-30)	0.15 (0.10-0.20)
Titanium Alloy	-	20 (10-25)	0.15 (0.10-0.17)	30 (20-35)	0.20 (0.15-0.25)	35 (30-40)	0.25 (0.20-0.30)

● BRS (l/d=3)

Work Material	Hardness	Drill Dia. $\phi 14.0 - \phi 20.0$		Drill Dia. $\phi 20.0 - \phi 30.0$	
		Cutting Speed (m/min)	Feed (mm/rev)	Cutting Speed (m/min)	Feed (mm/rev)
P Mild Steel	$\leq 180\text{HB}$	65 (50-75)	0.3 (0.20-0.40)	70 (55-85)	0.35 (0.20-0.45)
Structural Steel	Tensile Strength $400 - 500\text{N/mm}^2$	80 (70-90)	0.30 (0.25-0.35)	80 (70-90)	0.35 (0.30-0.45)
	Tensile Strength $490 - 610\text{N/mm}^2$	70 (60-80)	0.25 (0.20-0.30)	70 (60-80)	0.30 (0.20-0.40)
	Tensile Strength $570 - 720\text{N/mm}^2$	60 (50-70)	0.25 (0.20-0.30)	60 (50-70)	0.30 (0.20-0.35)
Carbon Steel Alloy Steel	180-280HB	60 (45-70)	0.25 (0.1-0.35)	65 (45-80)	0.30 (0.15-0.35)
	280-350HB	55 (40-65)	0.20 (0.15-0.35)	60 (45-70)	0.25 (0.15-0.35)
M Stainless Steel (Austenitic)	$\leq 200\text{HB}$	70 (50-90)	0.30 (0.20-0.40)	80 (60-100)	0.3 (0.20-0.40)
K Cast Iron	Tensile Strength $\leq 350\text{N/mm}^2$	75 (60-110)	0.30 (0.20-0.40)	80 (60-100)	0.35 (0.25-0.50)
	Tensile Strength $\leq 450\text{N/mm}^2$	75 (60-100)	0.30 (0.20-0.40)	80 (60-100)	0.35 (0.20-0.45)
	Tensile Strength $500 - 800\text{N/mm}^2$	70 (55-90)	0.25 (0.15-0.35)	75 (55-90)	0.30 (0.15-0.40)

● BRM (l/d=5)

Work Material	Hardness	Drill Dia. $\phi 14.0 - \phi 20.0$		Drill Dia. $\phi 20.0 - \phi 30.0$	
		Cutting Speed (m/min)	Feed (mm/rev)	Cutting Speed (m/min)	Feed (mm/rev)
P Mild Steel	$\leq 180\text{HB}$	65 (50-75)	0.30 (0.20-0.40)	70 (55-85)	0.35 (0.20-0.45)
Structural Steel	Tensile Strength $400 - 500\text{N/mm}^2$	70 (60-80)	0.30 (0.25-0.35)	70 (60-80)	0.35 (0.30-0.45)
	Tensile Strength $490 - 610\text{N/mm}^2$	60 (50-70)	0.25 (0.20-0.30)	60 (50-70)	0.30 (0.20-0.40)
	Tensile Strength $570 - 720\text{N/mm}^2$	50 (40-60)	0.25 (0.20-0.30)	50 (40-60)	0.30 (0.20-0.35)
Carbon Steel Alloy Steel	180-280HB	60 (45-70)	0.25 (0.15-0.35)	65 (45-80)	0.30 (0.15-0.40)
	280-350HB	55 (40-65)	0.20 (0.15-0.35)	60 (45-70)	0.25 (0.15-0.35)
M Stainless Steel (Austenitic)	$\leq 200\text{HB}$	60 (50-80)	0.25 (0.15-0.35)	65 (50-80)	0.30 (0.20-0.40)
K Cast Iron	Tensile Strength $\leq 350\text{N/mm}^2$	65 (50-100)	0.30 (0.20-0.40)	70 (50-100)	0.35 (0.25-0.50)
	Tensile Strength $\leq 450\text{N/mm}^2$	65 (50-90)	0.30 (0.20-0.40)	70 (50-90)	0.35 (0.20-0.45)
	Tensile Strength $500 - 800\text{N/mm}^2$	60 (45-80)	0.25 (0.15-0.35)	65 (45-80)	0.30 (0.15-0.40)

● BRK (l/d=7)

Work Material	Hardness	Drill Dia. $\phi 14.0 - \phi 16.0$		Drill Dia. $\phi 16.0 - \phi 20.0$		Drill Dia. $\phi 20.0 - \phi 30.0$	
		Cutting Speed (m/min)	Feed (mm/rev)	Cutting Speed (m/min)	Feed (mm/rev)	Cutting Speed (m/min)	Feed (mm/rev)
P Mild Steel	$\leq 180\text{HB}$	60 (40-75)	0.25 (0.15-0.30)	65 (40-80)	0.30 (0.20-0.35)	70 (50-85)	0.30 (0.20-0.35)
Carbon Steel Alloy Steel	180-280HB	55 (40-65)	0.25 (0.15-0.30)	60 (45-70)	0.30 (0.20-0.35)	65 (50-75)	0.30 (0.20-0.35)
	280-350HB	45 (30-55)	0.20 (0.10-0.25)	50 (35-60)	0.25 (0.15-0.30)	55 (40-65)	0.25 (0.15-0.30)
High Alloy Steel	200-280HB	40 (30-50)	0.20 (0.10-0.25)	45 (35-55)	0.25 (0.15-0.30)	50 (40-60)	0.25 (0.15-0.30)
K Cast Iron	Tensile Strength $\leq 350\text{N/mm}^2$	60 (50-70)	0.30 (0.20-0.35)	60 (50-80)	0.35 (0.25-0.40)	70 (60-90)	0.35 (0.25-0.40)
	Tensile Strength $\leq 450\text{N/mm}^2$	45 (30-60)	0.25 (0.15-0.30)	50 (35-60)	0.30 (0.20-0.35)	55 (40-65)	0.35 (0.20-0.35)

(Note 1) The above conditions are for general cutting. The cutting conditions need to be modified depending on power, rigidity of the machine and workpiece shape.
 (Note 2) Decrease the feed rate by 60% of the value above, until the full drill diameter is 3 to 5mm into the workpiece.

- : Stock Standard
- ★ : Stock Standard in Japan.
- : Non stock, produced to order only

DRILLING
BRA, BRS, BRM, BRK DRILLS





VIOLET

VIOLET HSSco Drills for high precision but economical drilling operations.

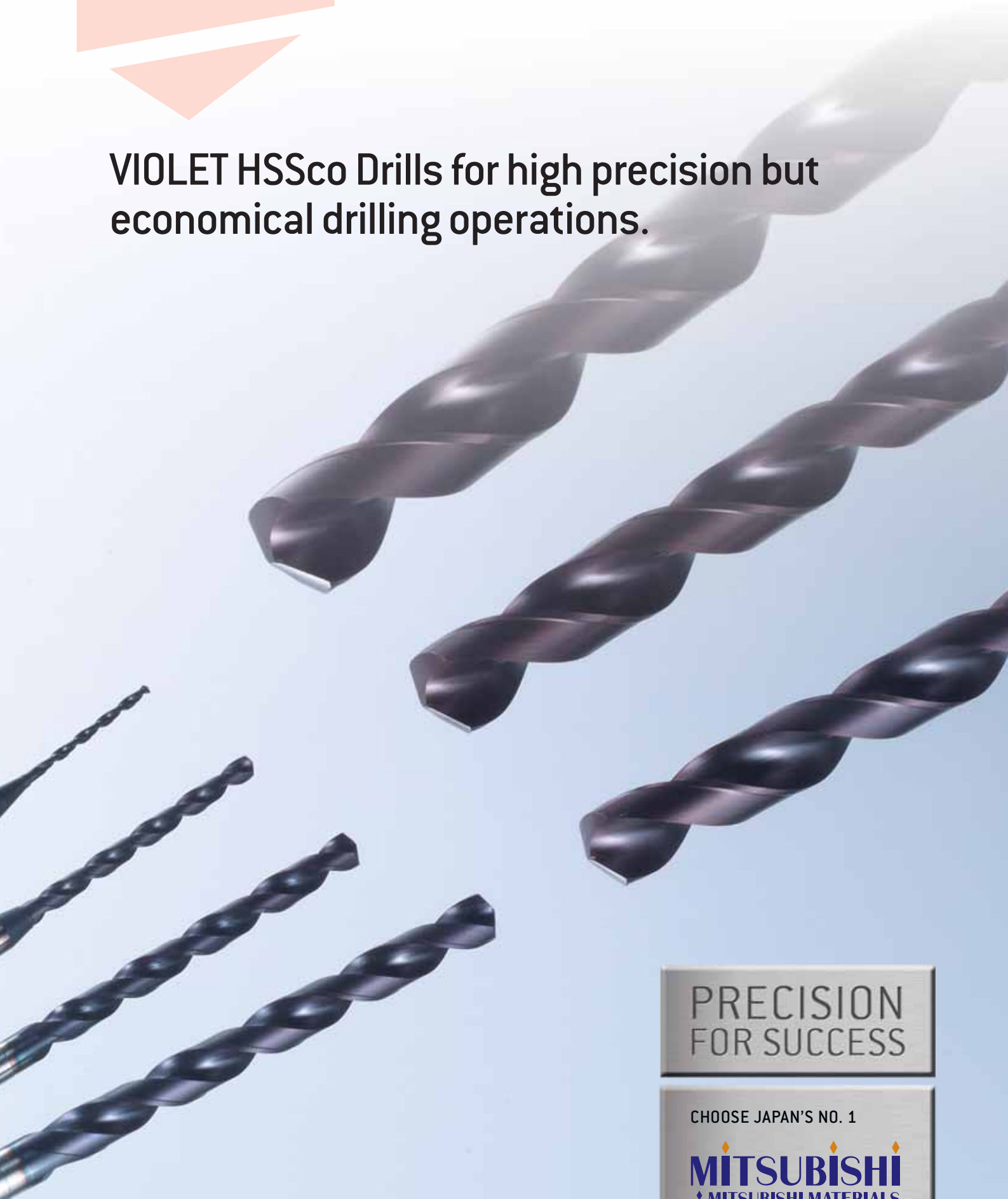

PRECISION
FOR SUCCESS

CHOOSE JAPAN'S NO. 1

mitsubishi
MITSUBISHI MATERIALS

www.mitsubishicarbide.com

VIOLET DRILLS

Features

1 Long and stable tool life

Drilling of stainless steel 304

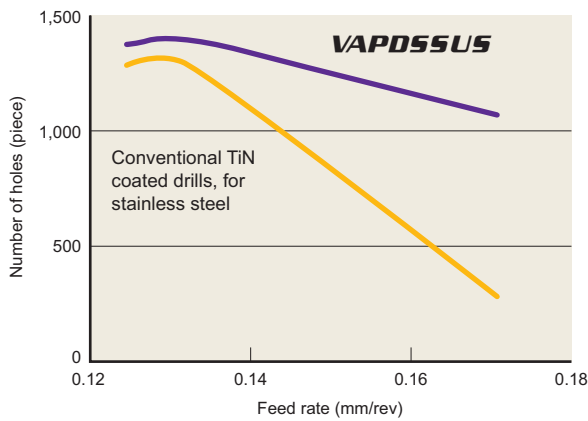

Drill	VAPDSSUS Ø6.0
Work material	Stainless steel 304
Revolution	800min ⁻¹ (15m/min)
Drilling depth	16mm Through
Cutting fluid	Emulsion

Drilling of D2 (225HB)

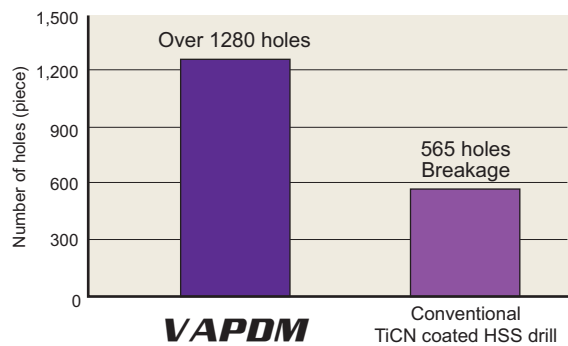

Drill	VAPDM Ø10.3
Work material	D2 (225HB)
Revolution	620min ⁻¹ (20m/min)
Feed rate	0.25mm/rev
Drilling depth	25mm Through
Cutting fluid	Emulsion

VIOLET DRILLS

DRILLING

FEATURES

2 High accuracy

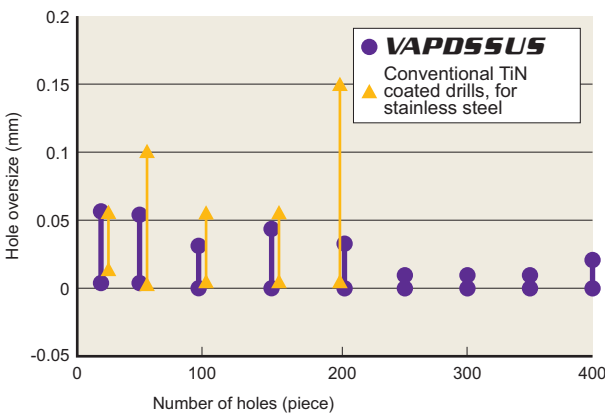

Drill	VAPDSSUS Ø10.0
Work material	Stainless steel 304
Revolution	480min ⁻¹ (15m/min)
Feed rate	0.22mm/rev
Drilling depth	16mm through
Cutting fluid	Emulsion

3 Good chip disposability

Shape of chips



Drill	VAPDMSUS Ø5.0
Work material	Stainless steel 304
Revolution	950min ⁻¹ (15m/min)
Feed rate	0.12mm/rev
Drilling depth	15mm (Blind hole)
Cutting fluid	Emulsion

Drill point of VAPDS/M

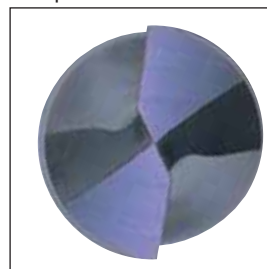

Drill point of VAPDSSUS/MSUS

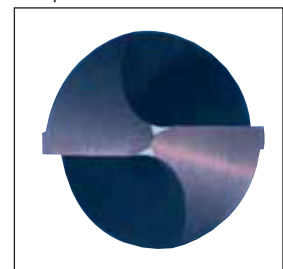

VIOLET DRILLS

VAPDS



P ✓ **M** **K** ✓ **S** **N** ✓ **H**



All drills except those with intervals of 0.1mm and under dia. 2mm have a tolerance of 0—0.009mm.

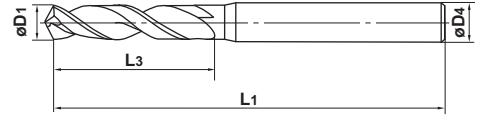

Unit : mm

Order Number	Dia. D1	Flute Length L3	Overall Length L1	Shank Dia. D4	Stock
VAPDSD0050	0.5	3	50	3	●
D0051	0.51	3	50	3	★
D0052	0.52	3	50	3	★
D0053	0.53	3	50	3	★
D0054	0.54	3	50	3	★
D0055	0.55	3	50	3	●
D0056	0.56	4	50	3	★
D0057	0.57	4	50	3	★
D0058	0.58	4	50	3	★
D0059	0.59	4	50	3	★
D0060	0.6	5	50	3	●
D0061	0.61	5	50	3	★
D0062	0.62	5	50	3	★
D0063	0.63	5	50	3	★
D0064	0.64	5	50	3	★
D0065	0.65	5	50	3	●
D0066	0.66	5	50	3	★
D0067	0.67	5	50	3	★
D0068	0.68	5	50	3	★
D0069	0.69	5	50	3	★
D0070	0.7	5	50	3	●
D0071	0.71	5	50	3	★
D0072	0.72	5	50	3	★
D0073	0.73	5	50	3	★
D0074	0.74	5	50	3	★
D0075	0.75	5	50	3	●
D0076	0.76	5	50	3	★
D0077	0.77	5	50	3	★
D0078	0.78	5	50	3	★
D0079	0.79	5	50	3	★
D0080	0.8	5	50	3	●
D0081	0.81	5	50	3	★
D0082	0.82	5	50	3	★
D0083	0.83	5	50	3	★
D0084	0.84	5	50	3	★
D0085	0.85	5	50	3	●
D0086	0.86	6	50	3	★
D0087	0.87	6	50	3	★

Order Number	Dia. D1	Flute Length L3	Overall Length L1	Shank Dia. D4	Stock
VAPDSD0088	0.88	6	50	3	★
D0089	0.89	6	50	3	★
D0090	0.9	6	50	3	●
D0091	0.91	6	50	3	★
D0092	0.92	6	50	3	★
D0093	0.93	6	50	3	★
D0094	0.94	6	50	3	★
D0095	0.95	6	50	3	●
D0096	0.96	6	50	3	★
D0097	0.97	6	50	3	★
D0098	0.98	6	50	3	★
D0099	0.99	6	50	3	★
D0100	1.0	6	50	3	●
D0101	1.01	6	50	3	★
D0102	1.02	6	50	3	★
D0103	1.03	6	50	3	★
D0104	1.04	6	50	3	★
D0105	1.05	6	50	3	●
D0106	1.06	6	50	3	★
D0107	1.07	8	55	3	★
D0108	1.08	8	55	3	★
D0109	1.09	8	55	3	★
D0110	1.1	8	55	3	●
D0111	1.11	8	55	3	★
D0112	1.12	8	55	3	★
D0113	1.13	8	55	3	★
D0114	1.14	8	55	3	★
D0115	1.15	8	55	3	●
D0116	1.16	8	55	3	★
D0117	1.17	8	55	3	★
D0118	1.18	8	55	3	★
D0119	1.19	8	55	3	★
D0120	1.2	8	55	3	●
D0121	1.21	8	55	3	★
D0122	1.22	8	55	3	★
D0123	1.23	8	55	3	★
D0124	1.24	8	55	3	★
D0125	1.25	8	55	3	●

VIOLET DRILLS



Ø 0.5~1.25

● : Stock standard
 ★ : Stock standard in Japan
 □ : Non stock, produce to order only

CUTTING CONDITIONS



D187

VIOLET DRILLS

VAPDS



P ✓ **M** **K** ✓ **S** **N** ✓ **H**



All drills except those with intervals of 0.1mm and under dia. 2mm have a tolerance of 0--0.009mm.

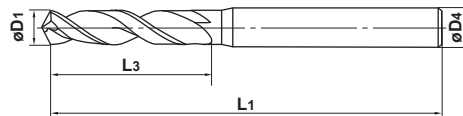

Unit : mm

Order Number	Dia. D1	Flute Length L3	Overall Length L1	Shank Dia. D4	Stock
VAPDSD0126	1.26	8	55	3	★
D0127	1.27	8	55	3	★
D0128	1.28	8	55	3	★
D0129	1.29	8	55	3	★
D0130	1.3	9	55	3	●
D0131	1.31	9	55	3	★
D0132	1.32	9	55	3	★
D0133	1.33	9	55	3	★
D0134	1.34	9	55	3	★
D0135	1.35	9	55	3	●
D0136	1.36	9	55	3	★
D0137	1.37	9	55	3	★
D0138	1.38	9	55	3	★
D0139	1.39	9	55	3	★
D0140	1.4	9	55	3	●
D0141	1.41	9	55	3	★
D0142	1.42	9	55	3	★
D0143	1.43	9	55	3	★
D0144	1.44	9	55	3	★
D0145	1.45	9	55	3	●
D0146	1.46	9	55	3	★
D0147	1.47	9	55	3	★
D0148	1.48	9	55	3	★
D0149	1.49	9	55	3	★
D0150	1.5	9	55	3	●
D0151	1.51	11	55	3	★
D0152	1.52	11	55	3	★
D0153	1.53	11	55	3	★
D0154	1.54	11	55	3	★
D0155	1.55	11	55	3	●
D0156	1.56	11	55	3	★
D0157	1.57	11	55	3	★
D0158	1.58	11	55	3	★
D0159	1.59	11	55	3	★
D0160	1.6	11	55	3	●
D0161	1.61	11	55	3	★
D0162	1.62	11	55	3	★
D0163	1.63	11	55	3	★

Order Number	Dia. D1	Flute Length L3	Overall Length L1	Shank Dia. D4	Stock
VAPDSD0164	1.64	11	55	3	★
D0165	1.65	11	55	3	●
D0166	1.66	11	55	3	★
D0167	1.67	11	55	3	★
D0168	1.68	11	55	3	★
D0169	1.69	11	55	3	★
D0170	1.7	11	55	3	●
D0171	1.71	11	55	3	★
D0172	1.72	11	55	3	★
D0173	1.73	11	55	3	★
D0174	1.74	11	55	3	★
D0175	1.75	11	55	3	●
D0176	1.76	11	55	3	★
D0177	1.77	11	55	3	★
D0178	1.78	11	55	3	★
D0179	1.79	11	55	3	★
D0180	1.8	11	55	3	●
D0181	1.81	11	55	3	★
D0182	1.82	11	55	3	★
D0183	1.83	11	55	3	★
D0184	1.84	11	55	3	★
D0185	1.85	11	55	3	●
D0186	1.86	11	55	3	★
D0187	1.87	11	55	3	★
D0188	1.88	11	55	3	★
D0189	1.89	11	55	3	★
D0190	1.9	12	55	3	●
D0191	1.91	12	60	3	★
D0192	1.92	12	60	3	★
D0193	1.93	12	60	3	★
D0194	1.94	12	60	3	★
D0195	1.95	12	60	3	●
D0196	1.96	12	60	3	★
D0197	1.97	12	60	3	★
D0198	1.98	12	60	3	★
D0199	1.99	12	60	3	★
D0200	2.0	12	60	3	●
D0205	2.05	12	60	3	●

VIOLET DRILLS



Ø 1.26~2.05

● : Stock standard
 ★ : Stock standard in Japan
 □ : Non stock, produce to order only

Unit : mm

Order Number	Dia. D1	Flute Length L3	Overall Length L1	Shank Dia. D4	Stock
VAPDSD0210	2.1	12	60	3	●
D0215	2.15	12	60	3	●
D0220	2.2	12	60	3	●
D0225	2.25	12	60	3	●
D0230	2.3	13	60	3	●
D0235	2.35	13	60	3	●
D0240	2.4	13	60	3	●
D0245	2.45	13	60	3	●
D0250	2.5	13	60	3	●
D0255	2.55	13	60	3	●
D0260	2.6	15	60	3	●
D0265	2.65	15	60	3	●
D0270	2.7	15	60	3	●
D0275	2.75	15	60	3	●
D0280	2.8	15	60	3	●
D0285	2.85	15	60	3	●
D0290	2.9	15	60	3	●
D0295	2.95	15	60	3	●
D0300	3.0	15	60	3	●
D0305	3.05	17	70	4	●
D0310	3.1	17	70	4	●
D0315	3.15	17	70	4	●
D0320	3.2	17	70	4	●
D0325	3.25	17	70	4	●
D0330	3.3	19	70	4	●
D0335	3.35	19	70	4	●
D0340	3.4	19	70	4	●
D0345	3.45	19	70	4	●
D0350	3.5	19	70	4	●
D0355	3.55	19	70	4	●
D0360	3.6	21	70	4	●
D0365	3.65	21	70	4	●
D0370	3.7	21	70	4	●
D0375	3.75	21	70	4	●
D0380	3.8	21	70	4	●
D0385	3.85	21	70	4	●
D0390	3.9	21	70	4	●
D0395	3.95	21	70	4	●
D0400	4.0	21	70	4	●
D0405	4.05	21	80	6	●
D0410	4.1	21	80	6	●
D0415	4.15	21	80	6	●
D0420	4.2	21	80	6	●
D0425	4.25	21	80	6	●
D0430	4.3	23	80	6	●
D0435	4.35	23	80	6	●
D0440	4.4	23	80	6	●
D0445	4.45	23	80	6	●

Order Number	Dia. D1	Flute Length L3	Overall Length L1	Shank Dia. D4	Stock
VAPDSD0450	4.5	23	80	6	●
D0455	4.55	23	80	6	●
D0460	4.6	25	80	6	●
D0465	4.65	25	80	6	●
D0470	4.7	25	80	6	●
D0475	4.75	25	80	6	●
D0480	4.8	25	80	6	●
D0485	4.85	25	80	6	●
D0490	4.9	25	80	6	●
D0495	4.95	25	80	6	●
D0500	5.0	25	80	6	●
D0505	5.05	25	80	6	●
D0510	5.1	25	80	6	●
D0515	5.15	25	80	6	●
D0520	5.2	25	80	6	●
D0525	5.25	25	80	6	●
D0530	5.3	25	80	6	●
D0535	5.35	27	80	6	●
D0540	5.4	27	80	6	●
D0545	5.45	27	80	6	●
D0550	5.5	27	80	6	●
D0555	5.55	27	80	6	●
D0560	5.6	27	80	6	●
D0565	5.65	27	80	6	●
D0570	5.7	27	80	6	●
D0575	5.75	27	80	6	●
D0580	5.8	27	80	6	●
D0585	5.85	27	80	6	●
D0590	5.9	27	80	6	●
D0595	5.95	27	80	6	●
D0600	6.0	27	80	6	●
D0605	6.05	30	80	8	●
D0610	6.1	30	80	8	●
D0615	6.15	30	80	8	●
D0620	6.2	30	80	8	●
D0625	6.25	30	80	8	●
D0630	6.3	30	80	8	●
D0635	6.35	30	80	8	●
D0640	6.4	30	80	8	●
D0645	6.45	30	80	8	●
D0650	6.5	30	80	8	●
D0655	6.55	30	80	8	●
D0660	6.6	30	80	8	●
D0665	6.65	30	80	8	●
D0670	6.7	30	80	8	●
D0675	6.75	32	80	8	●
D0680	6.8	32	80	8	●
D0685	6.85	32	80	8	●

VIOLET DRILLS

Ø 2.1~
6.85

CUTTING CONDITIONS



D196

D189

VIOLET DRILLS

VAPDS



P ✓ **M** **K** ✓ **S** **N** ✓ **H**



All drills except those with intervals of 0.1mm and under dia. 2mm have a tolerance of 0—-0.009mm.

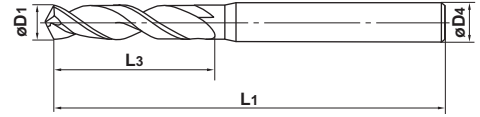

Unit : mm

Order Number	Dia. D1	Flute Length L3	Overall Length L1	Shank Dia. D4	Stock
VAPDSD0690	6.9	32	80	8	●
D0695	6.95	32	80	8	●
D0700	7.0	32	80	8	●
D0705	7.05	32	80	8	●
D0710	7.1	32	80	8	●
D0715	7.15	32	80	8	●
D0720	7.2	32	80	8	●
D0725	7.25	32	80	8	●
D0730	7.3	32	80	8	●
D0735	7.35	32	80	8	●
D0740	7.4	32	80	8	●
D0745	7.45	32	80	8	●
D0750	7.5	32	80	8	●
D0755	7.55	35	85	8	●
D0760	7.6	35	85	8	●
D0765	7.65	35	85	8	●
D0770	7.7	35	85	8	●
D0775	7.75	35	85	8	●
D0780	7.8	35	85	8	●
D0785	7.85	35	85	8	●
D0790	7.9	35	85	8	●
D0795	7.95	35	85	8	●
D0800	8.0	35	85	8	●
D0805	8.05	35	90	10	●
D0810	8.1	35	90	10	●
D0815	8.15	35	90	10	●
D0820	8.2	35	90	10	●
D0825	8.25	35	90	10	●
D0830	8.3	35	90	10	●
D0835	8.35	35	90	10	●
D0840	8.4	35	90	10	●
D0845	8.45	35	90	10	●
D0850	8.5	35	90	10	●
D0855	8.55	38	93	10	●
D0860	8.6	38	93	10	●
D0865	8.65	38	93	10	●
D0870	8.7	38	93	10	●
D0875	8.75	38	93	10	●

Order Number	Dia. D1	Flute Length L3	Overall Length L1	Shank Dia. D4	Stock
VAPDSD0880	8.8	38	93	10	●
D0885	8.85	38	93	10	●
D0890	8.9	38	93	10	●
D0895	8.95	38	93	10	●
D0900	9.0	38	93	10	●
D0905	9.05	38	93	10	●
D0910	9.1	38	93	10	●
D0915	9.15	38	93	10	●
D0920	9.2	38	93	10	●
D0925	9.25	38	93	10	●
D0930	9.3	38	93	10	●
D0935	9.35	38	93	10	●
D0940	9.4	38	93	10	●
D0945	9.45	38	93	10	●
D0950	9.5	38	93	10	●
D0955	9.55	41	96	10	●
D0960	9.6	41	96	10	●
D0965	9.65	41	96	10	●
D0970	9.7	41	96	10	●
D0975	9.75	41	96	10	●
D0980	9.8	41	96	10	●
D0985	9.85	41	96	10	●
D0990	9.9	41	96	10	●
D0995	9.95	41	96	10	●
D1000	10.0	41	96	10	●
D1005	10.05	41	101	12	●
D1010	10.1	41	101	12	●
D1015	10.15	41	101	12	●
D1020	10.2	41	101	12	●
D1025	10.25	41	101	12	●
D1030	10.3	41	101	12	●
D1035	10.35	41	101	12	●
D1040	10.4	41	101	12	●
D1045	10.45	41	101	12	●
D1050	10.5	41	101	12	●
D1055	10.55	41	101	12	●
D1060	10.6	41	101	12	●
D1065	10.65	45	105	12	●

VIOLET DRILLS



Ø 6.9~10.65

● : Stock standard
 ★ : Stock standard in Japan
 □ : Non stock, produce to order only

Unit : mm

Order Number	Dia. D1	Flute Length L3	Overall Length L1	Shank Dia. D4	Stock
VAPDSD1070	10.7	45	105	12	●
D1075	10.75	45	105	12	●
D1080	10.8	45	105	12	●
D1085	10.85	45	105	12	●
D1090	10.9	45	105	12	●
D1095	10.95	45	105	12	●
D1100	11.0	45	105	12	●
D1105	11.05	45	105	12	●
D1110	11.1	45	105	12	●
D1115	11.15	45	105	12	●
D1120	11.2	45	105	12	●
D1125	11.25	45	105	12	●
D1130	11.3	45	105	12	●
D1135	11.35	45	105	12	●
D1140	11.4	45	105	12	●
D1145	11.45	45	105	12	●
D1150	11.5	45	105	12	●
D1155	11.55	45	105	12	●
D1160	11.6	45	105	12	●
D1165	11.65	45	105	12	●
D1170	11.7	45	105	12	●
D1175	11.75	45	105	12	●
D1180	11.8	45	105	12	●
D1185	11.85	49	109	12	●
D1190	11.9	49	109	12	●
D1195	11.95	49	109	12	●
D1200	12.0	49	109	12	●
D1210	12.1	49	109	12	●
D1220	12.2	49	109	12	●
D1230	12.3	49	109	12	●
D1240	12.4	49	109	12	●
D1250	12.5	49	109	12	●
D1260	12.6	49	109	12	●
D1270	12.7	49	109	12	●
D1280	12.8	49	109	12	●
D1290	12.9	49	109	12	●
D1300	13.0	49	109	12	●

VIOLET DRILLS



Ø 10.7~
13.0

CUTTING CONDITIONS



D191

VIOLET DRILLS

VAPDM



P	M	K	S	N	H
✓		✓		✓	



All drills except those with intervals of 0.1mm and under dia. 2mm have a tolerance of 0-0.009mm.

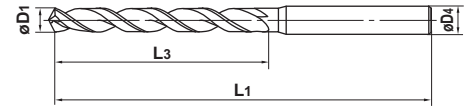

Unit : mm

Order Number	Dia. D1	Flute Length L3	Overall Length L1	Shank Dia. D4	Stock
VAPDMD0050	0.5	6	50	3	●
D0055	0.55	6	50	3	●
D0060	0.6	8	50	3	●
D0065	0.65	8	50	3	●
D0070	0.7	10	50	3	●
D0075	0.75	10	50	3	●
D0080	0.8	10	50	3	●
D0085	0.85	10	50	3	●
D0090	0.9	12	50	3	●
D0095	0.95	12	50	3	●
D0100	1.0	12	60	3	●
D0105	1.05	12	60	3	●
D0110	1.1	16	60	3	●
D0115	1.15	16	60	3	●
D0120	1.2	16	60	3	●
D0125	1.25	16	60	3	●
D0130	1.3	16	60	3	●
D0135	1.35	18	60	3	●
D0140	1.4	18	60	3	●
D0145	1.45	18	60	3	●
D0150	1.5	18	60	3	●
D0155	1.55	20	60	3	●
D0160	1.6	20	60	3	●
D0165	1.65	20	60	3	●
D0170	1.7	20	60	3	●
D0175	1.75	20	60	3	●
D0180	1.8	22	60	3	●
D0185	1.85	22	60	3	●
D0190	1.9	22	60	3	●
D0195	1.95	23	60	3	●
D0200	2.0	23	70	3	●
D0205	2.05	23	70	3	●
D0210	2.1	23	70	3	●
D0215	2.15	23	70	3	●
D0220	2.2	26	70	3	●
D0225	2.25	26	70	3	●
D0230	2.3	26	70	3	●
D0235	2.35	26	70	3	●

Order Number	Dia. D1	Flute Length L3	Overall Length L1	Shank Dia. D4	Stock
VAPDMD0240	2.4	29	70	3	●
D0245	2.45	29	70	3	●
D0250	2.5	29	70	3	●
D0255	2.55	29	70	3	●
D0260	2.6	29	70	3	●
D0265	2.65	29	70	3	●
D0270	2.7	32	70	3	●
D0275	2.75	32	70	3	●
D0280	2.8	32	70	3	●
D0285	2.85	32	70	3	●
D0290	2.9	32	70	3	●
D0295	2.95	32	70	3	●
D0300	3.0	32	70	3	●
D0305	3.05	35	85	4	●
D0310	3.1	35	85	4	●
D0315	3.15	35	85	4	●
D0320	3.2	35	85	4	●
D0325	3.25	35	85	4	●
D0330	3.3	35	85	4	●
D0335	3.35	35	85	4	●
D0340	3.4	38	85	4	●
D0345	3.45	38	85	4	●
D0350	3.5	38	85	4	●
D0355	3.55	38	85	4	●
D0360	3.6	38	85	4	●
D0365	3.65	38	85	4	●
D0370	3.7	38	85	4	●
D0375	3.75	42	85	4	●
D0380	3.8	42	85	4	●
D0385	3.85	42	85	4	●
D0390	3.9	42	85	4	●
D0395	3.95	42	85	4	●
D0400	4.0	42	85	4	●
D0405	4.05	42	100	6	●
D0410	4.1	42	100	6	●
D0415	4.15	42	100	6	●
D0420	4.2	42	100	6	●
D0425	4.25	46	100	6	●

DRILLING VIOLET DRILLS

DRILLING

 Ø 0.5~4.25

● : Stock standard
 ★ : Stock standard in Japan
 □ : Non stock, produce to order only

Unit : mm

Order Number	Dia. D1	Flute Length L3	Overall Length L1	Shank Dia. D4	Stock
VAPDMD0430	4.3	46	100	6	●
D0435	4.35	46	100	6	●
D0440	4.4	46	100	6	●
D0445	4.45	46	100	6	●
D0450	4.5	46	100	6	●
D0455	4.55	46	100	6	●
D0460	4.6	46	100	6	●
D0465	4.65	46	100	6	●
D0470	4.7	46	100	6	●
D0475	4.75	46	100	6	●
D0480	4.8	51	100	6	●
D0485	4.85	51	100	6	●
D0490	4.9	51	100	6	●
D0495	4.95	51	100	6	●
D0500	5.0	51	100	6	●
D0505	5.05	51	100	6	●
D0510	5.1	51	100	6	●
D0515	5.15	51	100	6	●
D0520	5.2	51	100	6	●
D0525	5.25	51	100	6	●
D0530	5.3	51	100	6	●
D0535	5.35	56	106	6	●
D0540	5.4	56	106	6	●
D0545	5.45	56	106	6	●
D0550	5.5	56	106	6	●
D0555	5.55	56	106	6	●
D0560	5.6	56	106	6	●
D0565	5.65	56	106	6	●
D0570	5.7	56	106	6	●
D0575	5.75	56	106	6	●
D0580	5.8	56	106	6	●
D0585	5.85	56	106	6	●
D0590	5.9	56	106	6	●
D0595	5.95	56	106	6	●
D0600	6.0	56	106	6	●
D0605	6.05	62	112	8	●
D0610	6.1	62	112	8	●
D0615	6.15	62	112	8	●
D0620	6.2	62	112	8	●
D0625	6.25	62	112	8	●
D0630	6.3	62	112	8	●
D0635	6.35	62	112	8	●
D0640	6.4	62	112	8	●
D0645	6.45	62	112	8	●
D0650	6.5	62	112	8	●
D0655	6.55	62	112	8	●
D0660	6.6	62	112	8	●
D0665	6.65	62	112	8	●

Order Number	Dia. D1	Flute Length L3	Overall Length L1	Shank Dia. D4	Stock
VAPDMD0670	6.7	62	112	8	●
D0675	6.75	67	117	8	●
D0680	6.8	67	117	8	●
D0685	6.85	67	117	8	●
D0690	6.9	67	117	8	●
D0695	6.95	67	117	8	●
D0700	7.0	67	117	8	●
D0705	7.05	67	117	8	●
D0710	7.1	67	117	8	●
D0715	7.15	67	117	8	●
D0720	7.2	67	117	8	●
D0725	7.25	67	117	8	●
D0730	7.3	67	117	8	●
D0735	7.35	67	117	8	●
D0740	7.4	67	117	8	●
D0745	7.45	67	117	8	●
D0750	7.5	67	117	8	●
D0755	7.55	73	123	8	●
D0760	7.6	73	123	8	●
D0765	7.65	73	123	8	●
D0770	7.7	73	123	8	●
D0775	7.75	73	123	8	●
D0780	7.8	73	123	8	●
D0785	7.85	73	123	8	●
D0790	7.9	73	123	8	●
D0795	7.95	73	123	8	●
D0800	8.0	73	123	8	●
D0805	8.05	73	128	10	●
D0810	8.1	73	128	10	●
D0815	8.15	73	128	10	●
D0820	8.2	73	128	10	●
D0825	8.25	73	128	10	●
D0830	8.3	73	128	10	●
D0835	8.35	73	128	10	●
D0840	8.4	73	128	10	●
D0845	8.45	73	128	10	●
D0850	8.5	73	128	10	●
D0855	8.55	79	134	10	●
D0860	8.6	79	134	10	●
D0865	8.65	79	134	10	●
D0870	8.7	79	134	10	●
D0875	8.75	79	134	10	●
D0880	8.8	79	134	10	●
D0885	8.85	79	134	10	●
D0890	8.9	79	134	10	●
D0895	8.95	79	134	10	●
D0900	9.0	79	134	10	●
D0910	9.1	79	134	10	●

VIOLET DRILLS

Ø 4.3~
9.1

CUTTING CONDITIONS

D196

D193

VIOLET DRILLS

VAPDM



P	M	K	S	N	H
✓		✓		✓	



All drills except those with intervals of 0.1mm and under dia. 2mm have a tolerance of 0—0.009mm.

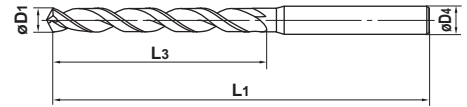

Unit : mm

Order Number	Dia. D1	Flute Length L3	Overall Length L1	Shank Dia. D4	Stock
VAPDMD0920	9.2	79	134	10	●
D0930	9.3	79	134	10	●
D0940	9.4	79	134	10	●
D0950	9.5	79	134	10	●
D0960	9.6	85	140	10	●
D0970	9.7	85	140	10	●
D0980	9.8	85	140	10	●
D0990	9.9	85	140	10	●
D1000	10.0	85	140	10	●
D1010	10.1	85	145	12	●
D1020	10.2	85	145	12	●
D1030	10.3	85	145	12	●
D1040	10.4	85	145	12	●
D1050	10.5	85	145	12	●
D1060	10.6	85	145	12	●
D1070	10.7	92	152	12	●
D1080	10.8	92	152	12	●
D1090	10.9	92	152	12	●
D1100	11.0	92	152	12	●
D1110	11.1	92	152	12	●
D1120	11.2	92	152	12	●
D1130	11.3	92	152	12	●
D1140	11.4	92	152	12	●
D1150	11.5	92	152	12	●
D1160	11.6	92	152	12	●
D1170	11.7	92	152	12	●
D1180	11.8	92	152	12	●
D1190	11.9	99	159	12	●
D1200	12.0	99	159	12	●
D1210	12.1	99	159	12	●
D1220	12.2	99	159	12	●
D1230	12.3	99	159	12	●
D1240	12.4	99	159	12	●
D1250	12.5	99	159	12	●
D1260	12.6	99	159	12	●
D1270	12.7	99	159	12	●
D1280	12.8	99	159	12	●
D1290	12.9	99	159	12	●

Order Number	Dia. D1	Flute Length L3	Overall Length L1	Shank Dia. D4	Stock
VAPDMD1300	13.0	99	159	12	●
D1350	13.5	100	160	16	●
D1400	14.0	100	160	16	●
D1410	14.1	105	165	16	●
D1420	14.2	105	165	16	●
D1450	14.5	105	165	16	●
D1500	15.0	105	165	16	●
D1550	15.5	110	170	16	●
D1560	15.6	110	170	16	●
D1570	15.7	110	170	16	●
D1600	16.0	110	170	16	●
D1650	16.5	110	175	20	●
D1700	17.0	110	175	20	●
D1750	17.5	115	180	20	●
D1760	17.6	115	180	20	●
D1770	17.7	115	180	20	●
D1800	18.0	115	180	20	●
D1850	18.5	120	185	20	●
D1900	19.0	120	185	20	●
D1950	19.5	120	185	20	●
D1960	19.6	120	185	20	●
D1970	19.7	120	185	20	●
D2000	20.0	120	185	20	●
D2050	20.5	125	200	25	●
D2100	21.0	125	200	25	●
D2110	21.1	125	200	25	●
D2120	21.2	125	200	25	●
D2150	21.5	125	200	25	●
D2200	22.0	125	200	25	●
D2250	22.5	130	205	25	●
D2300	23.0	130	205	25	●
D2350	23.5	130	205	25	●
D2400	24.0	135	210	25	●
D2450	24.5	135	210	25	●
D2500	25.0	135	210	25	●
D2550	25.5	140	220	32	●
D2600	26.0	140	220	32	●
D2650	26.5	140	220	32	●

VIOLET DRILLS

DRILLING

Ø 9.2~26.5

● : Stock standard
 ★ : Stock standard in Japan
 □ : Non stock, produce to order only

Unit : mm

Order Number	Dia. D1	Flute Length L3	Overall Length L1	Shank Dia. D4	Stock
VAPDMD2700	27.0	140	220	32	●
D2800	28.0	140	220	32	●
D2900	29.0	145	225	32	●
D3000	30.0	145	225	32	●
D3100	31.0	150	230	32	●
D3200	32.0	155	235	32	●

VIOLET DRILLS



Ø 27.0~
32.0

CUTTING CONDITIONS



D196

D195

VIOLET DRILLS

VAPDS VAPDM

RECOMMENDED CUTTING CONDITIONS FOR VIOLET DRILLS

VAPDS (Standard drilling depth : 3 times or below the drill diameter)

Work material	Structural steel		Carbon steel Ck55 Alloy steel 070M55 Cast iron		Alloy tool steel X210Cr12 (Low-hardness materials) Ferritic stainless steel X10CrA118, X10CrA113 Martensitic stainless steel X20Cr13, X10CrA113		Alloy tool steel W. Nr. 1.2344 (H13) (- 40HRC) Precipitation hardening stainless steel X7CrNiAl177	
	Dia. (mm)	Revolution (min ⁻¹)	Feed rate (mm/rev)	Revolution (min ⁻¹)	Feed rate (mm/rev)	Revolution (min ⁻¹)	Feed rate (mm/rev)	Revolution (min ⁻¹)
0.5	18,000	0.02	16,000	0.02	9,000	0.02	8,200	0.02
1.0	12,000	0.05	10,000	0.05	6,300	0.05	5,500	0.04
2.0	6,400	0.09	5,500	0.09	3,200	0.09	2,900	0.05
3.0	4,300	0.13	3,700	0.13	2,100	0.13	1,900	0.06
4.0	3,200	0.15	2,800	0.15	1,600	0.15	1,400	0.08
5.0	2,600	0.18	2,200	0.18	1,300	0.18	1,100	0.10
6.0	2,100	0.19	1,800	0.19	1,100	0.20	950	0.11
8.0	1,600	0.24	1,400	0.24	800	0.22	720	0.13
10.0	1,300	0.28	1,100	0.28	640	0.25	570	0.15
12.0	1,100	0.34	930	0.34	530	0.30	480	0.17
13.0	980	0.36	860	0.36	490	0.32	440	0.19

VAPDM (Standard drilling depth : 5 times or below the drill diameter)

Work material	Structural steel		Carbon steel Ck55 Alloy steel 070M55 Cast iron		Alloy tool steel X210Cr12 (Low-hardness materials) Ferritic stainless steel X10CrA118, X10CrA113 Martensitic stainless steel X20Cr13, X10CrA113		Alloy tool steel W. Nr. 1.2344 (H13) (- 40HRC) Precipitation hardening stainless steel X7CrNiAl177	
	Dia. (mm)	Revolution (min ⁻¹)	Feed rate (mm/rev)	Revolution (min ⁻¹)	Feed rate (mm/rev)	Revolution (min ⁻¹)	Feed rate (mm/rev)	Revolution (min ⁻¹)
0.5	17,000	0.01	12,800	0.01	8,000	0.01	6,600	0.01
1.0	11,000	0.05	8,300	0.05	5,000	0.05	4,100	0.04
2.0	6,400	0.09	4,800	0.09	2,900	0.06	2,400	0.05
3.0	4,300	0.13	3,200	0.13	1,900	0.10	1,600	0.06
4.0	3,200	0.15	2,400	0.15	1,400	0.10	1,200	0.08
5.0	2,600	0.18	1,900	0.18	1,100	0.13	950	0.10
6.0	2,100	0.19	1,600	0.20	950	0.15	800	0.11
8.0	1,600	0.24	1,200	0.22	720	0.18	600	0.13
10.0	1,300	0.28	950	0.25	570	0.21	480	0.15
12.0	1,100	0.34	800	0.30	480	0.25	400	0.17
14.0	910	0.39	680	0.35	410	0.30	340	0.21
15.0	850	0.40	640	0.36	380	0.31	320	0.22
16.0	800	0.42	600	0.38	360	0.32	300	0.23
18.0	710	0.44	530	0.40	320	0.34	270	0.24
20.0	570	0.44	450	0.40	250	0.34	220	0.24
22.0	520	0.46	410	0.42	230	0.36	200	0.25
24.0	480	0.48	370	0.44	210	0.37	190	0.26
26.0	440	0.51	340	0.46	200	0.39	170	0.28
28.0	410	0.53	320	0.48	180	0.41	160	0.29
30.0	380	0.55	300	0.50	170	0.43	150	0.30
32.0	360	0.55	280	0.50	160	0.43	140	0.30

- 1) Please reduce the revolution and feed rate when the workpiece clamping lacks rigidity or the machine has limitations.
- 2) Please use a collet type drill chuck or a milling chuck.
- 3) Use sufficient cutting fluid.
- 4) VAPDSUS and VAPDMSUS are recommended for austenitic stainless steels (X5CrNi1810).
- 5) When drilling holes greater than 4 x drill diameter hole depths, please use a peck feed.

The above mentioned cutting conditions are standard when using water soluble cutting fluid.
Please reduce the revolutions when using non-water soluble cutting fluid.



CUTTING DATA



VAPDSSUS/
VAPDMSUS

**VIOLET HSSco Drills for stainless steel drilling
with stable tool life.**



PRECISION
FOR SUCCESS

CHOOSE JAPAN'S NO. 1

MITSUBISHI
▲ **MITSUBISHI MATERIALS**

www.mitsubishicarbide.com

VIOLET DRILLS

VAPDSSUS



P	M	K	S	N	H
✓	✓	✓		✓	



All drills except those with intervals of 0.1mm and under dia. 4mm have a tolerance of 0--0.009mm.

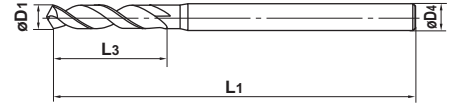

Unit : mm

Order Number	Dia. D1	Flute Length L3	Overall Length L1	Shank Dia. D4	Stock
VAPDSSUSD0050	0.5	3	50	3	●
D0051	0.51	3	50	3	★
D0052	0.52	3	50	3	★
D0053	0.53	3	50	3	★
D0054	0.54	3	50	3	★
D0055	0.55	3	50	3	●
D0056	0.56	4	50	3	★
D0057	0.57	4	50	3	★
D0058	0.58	4	50	3	★
D0059	0.59	4	50	3	★
D0060	0.6	5	50	3	●
D0061	0.61	5	50	3	★
D0062	0.62	5	50	3	★
D0063	0.63	5	50	3	★
D0064	0.64	5	50	3	★
D0065	0.65	5	50	3	●
D0066	0.66	5	50	3	★
D0067	0.67	5	50	3	★
D0068	0.68	5	50	3	★
D0069	0.69	5	50	3	★
D0070	0.7	5	50	3	●
D0071	0.71	5	50	3	★
D0072	0.72	5	50	3	★
D0073	0.73	5	50	3	★
D0074	0.74	5	50	3	★
D0075	0.75	5	50	3	●
D0076	0.76	5	50	3	★
D0077	0.77	5	50	3	★
D0078	0.78	5	50	3	★
D0079	0.79	5	50	3	★
D0080	0.8	5	50	3	●
D0081	0.81	5	50	3	★
D0082	0.82	5	50	3	★
D0083	0.83	5	50	3	★
D0084	0.84	5	50	3	★
D0085	0.85	5	50	3	●
D0086	0.86	6	50	3	★
D0087	0.87	6	50	3	★
D0088	0.88	6	50	3	★
D0089	0.89	6	50	3	★

Order Number	Dia. D1	Flute Length L3	Overall Length L1	Shank Dia. D4	Stock
VAPDSSUSD0090	0.9	6	50	3	●
D0091	0.91	6	50	3	★
D0092	0.92	6	50	3	★
D0093	0.93	6	50	3	★
D0094	0.94	6	50	3	★
D0095	0.95	6	50	3	●
D0096	0.96	6	50	3	★
D0097	0.97	6	50	3	★
D0098	0.98	6	50	3	★
D0099	0.99	6	50	3	★
D0100	1.0	6	50	3	●
D0101	1.01	6	50	3	★
D0102	1.02	6	50	3	★
D0103	1.03	6	50	3	★
D0104	1.04	6	50	3	★
D0105	1.05	6	50	3	●
D0106	1.06	6	50	3	★
D0107	1.07	8	55	3	★
D0108	1.08	8	55	3	★
D0109	1.09	8	55	3	★
D0110	1.1	8	55	3	●
D0111	1.11	8	55	3	★
D0112	1.12	8	55	3	★
D0113	1.13	8	55	3	★
D0114	1.14	8	55	3	★
D0115	1.15	8	55	3	●
D0116	1.16	8	55	3	★
D0117	1.17	8	55	3	★
D0118	1.18	8	55	3	★
D0119	1.19	8	55	3	★
D0120	1.2	8	55	3	●
D0121	1.21	8	55	3	★
D0122	1.22	8	55	3	★
D0123	1.23	8	55	3	★
D0124	1.24	8	55	3	★
D0125	1.25	8	55	3	●
D0126	1.26	8	55	3	★
D0127	1.27	8	55	3	★
D0128	1.28	8	55	3	★
D0129	1.29	8	55	3	★

VAPDSSUS

DRILLING

Ø 0.5~1.29

● : Stock standard
 ★ : Stock standard in Japan
 □ : Non stock, produce to order only

Unit : mm

Order Number	Dia. D1	Flute Length L3	Overall Length L1	Shank Dia. D4	Stock
VAPDSSUSD0130	1.3	9	55	3	●
D0131	1.31	9	55	3	★
D0132	1.32	9	55	3	★
D0133	1.33	9	55	3	★
D0134	1.34	9	55	3	★
D0135	1.35	9	55	3	●
D0136	1.36	9	55	3	★
D0137	1.37	9	55	3	★
D0138	1.38	9	55	3	★
D0139	1.39	9	55	3	★
D0140	1.4	9	55	3	●
D0141	1.41	9	55	3	★
D0142	1.42	9	55	3	★
D0143	1.43	9	55	3	★
D0144	1.44	9	55	3	★
D0145	1.45	9	55	3	●
D0146	1.46	9	55	3	★
D0147	1.47	9	55	3	★
D0148	1.48	9	55	3	★
D0149	1.49	9	55	3	★
D0150	1.5	9	55	3	●
D0151	1.51	11	55	3	★
D0152	1.52	11	55	3	★
D0153	1.53	11	55	3	★
D0154	1.54	11	55	3	★
D0155	1.55	11	55	3	●
D0156	1.56	11	55	3	★
D0157	1.57	11	55	3	★
D0158	1.58	11	55	3	★
D0159	1.59	11	55	3	★
D0160	1.6	11	55	3	●
D0161	1.61	11	55	3	★
D0162	1.62	11	55	3	★
D0163	1.63	11	55	3	★
D0164	1.64	11	55	3	★
D0165	1.65	11	55	3	●
D0166	1.66	11	55	3	★
D0167	1.67	11	55	3	★
D0168	1.68	11	55	3	★
D0169	1.69	11	55	3	★
D0170	1.7	11	55	3	●
D0171	1.71	11	55	3	★
D0172	1.72	11	55	3	★
D0173	1.73	11	55	3	★
D0174	1.74	11	55	3	★
D0175	1.75	11	55	3	●
D0176	1.76	11	55	3	★
D0177	1.77	11	55	3	★
D0178	1.78	11	55	3	★
D0179	1.79	11	55	3	★

Order Number	Dia. D1	Flute Length L3	Overall Length L1	Shank Dia. D4	Stock
VAPDSSUSD0180	1.8	11	55	3	●
D0181	1.81	11	55	3	★
D0182	1.82	11	55	3	★
D0183	1.83	11	55	3	★
D0184	1.84	11	55	3	★
D0185	1.85	11	55	3	●
D0186	1.86	11	55	3	★
D0187	1.87	11	55	3	★
D0188	1.88	11	55	3	★
D0189	1.89	11	55	3	★
D0190	1.9	12	55	3	●
D0191	1.91	12	60	3	★
D0192	1.92	12	60	3	★
D0193	1.93	12	60	3	★
D0194	1.94	12	60	3	★
D0195	1.95	12	60	3	●
D0196	1.96	12	60	3	★
D0197	1.97	12	60	3	★
D0198	1.98	12	60	3	★
D0199	1.99	12	60	3	★
D0200	2.0	12	60	3	●
D0201	2.01	12	60	3	★
D0202	2.02	12	60	3	★
D0203	2.03	12	60	3	★
D0204	2.04	12	60	3	★
D0205	2.05	12	60	3	●
D0206	2.06	12	60	3	★
D0207	2.07	12	60	3	★
D0208	2.08	12	60	3	★
D0209	2.09	12	60	3	★
D0210	2.1	12	60	3	●
D0211	2.11	12	60	3	★
D0212	2.12	12	60	3	★
D0213	2.13	12	60	3	★
D0214	2.14	12	60	3	★
D0215	2.15	12	60	3	●
D0216	2.16	12	60	3	★
D0217	2.17	12	60	3	★
D0218	2.18	12	60	3	★
D0219	2.19	12	60	3	★
D0220	2.2	12	60	3	●
D0221	2.21	12	60	3	★
D0222	2.22	12	60	3	★
D0223	2.23	12	60	3	★
D0224	2.24	12	60	3	★
D0225	2.25	12	60	3	●
D0226	2.26	12	60	3	★
D0227	2.27	12	60	3	★
D0228	2.28	12	60	3	★
D0229	2.29	12	60	3	★

VIOLET DRILLS

Ø 1.3~
2.29

CUTTING CONDITIONS

D210

D199

VIOLET DRILLS

VAPDSSUS



All drills except those with intervals of 0.1mm and under dia. 4mm have a tolerance of 0--0.009mm.

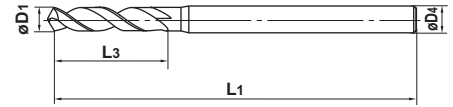

Unit : mm

VIOLET DRILLS



Ø2.3~
3.09

Order Number	Dia. D1	Flute Length L3	Overall Length L1	Shank Dia. D4	Stock
VAPDSSUSD0230	2.3	13	60	3	●
D0231	2.31	13	60	3	★
D0232	2.32	13	60	3	★
D0233	2.33	13	60	3	★
D0234	2.34	13	60	3	★
D0235	2.35	13	60	3	●
D0236	2.36	13	60	3	★
D0237	2.37	13	60	3	★
D0238	2.38	13	60	3	★
D0239	2.39	13	60	3	★
D0240	2.4	13	60	3	●
D0241	2.41	13	60	3	★
D0242	2.42	13	60	3	★
D0243	2.43	13	60	3	★
D0244	2.44	13	60	3	★
D0245	2.45	13	60	3	●
D0246	2.46	13	60	3	★
D0247	2.47	13	60	3	★
D0248	2.48	13	60	3	★
D0249	2.49	13	60	3	★
D0250	2.5	13	60	3	●
D0251	2.51	13	60	3	★
D0252	2.52	13	60	3	★
D0253	2.53	13	60	3	★
D0254	2.54	13	60	3	★
D0255	2.55	13	60	3	●
D0256	2.56	13	60	3	★
D0257	2.57	13	60	3	★
D0258	2.58	13	60	3	★
D0259	2.59	13	60	3	★
D0260	2.6	15	60	3	●
D0261	2.61	15	60	3	★
D0262	2.62	15	60	3	★
D0263	2.63	15	60	3	★
D0264	2.64	15	60	3	★
D0265	2.65	15	60	3	●
D0266	2.66	15	60	3	★
D0267	2.67	15	60	3	★
D0268	2.68	15	60	3	★
D0269	2.69	15	60	3	★

Order Number	Dia. D1	Flute Length L3	Overall Length L1	Shank Dia. D4	Stock
VAPDSSUSD0270	2.7	15	60	3	●
D0271	2.71	15	60	3	★
D0272	2.72	15	60	3	★
D0273	2.73	15	60	3	★
D0274	2.74	15	60	3	★
D0275	2.75	15	60	3	●
D0276	2.76	15	60	3	★
D0277	2.77	15	60	3	★
D0278	2.78	15	60	3	★
D0279	2.79	15	60	3	★
D0280	2.8	15	60	3	●
D0281	2.81	15	60	3	★
D0282	2.82	15	60	3	★
D0283	2.83	15	60	3	★
D0284	2.84	15	60	3	★
D0285	2.85	15	60	3	●
D0286	2.86	15	60	3	★
D0287	2.87	15	60	3	★
D0288	2.88	15	60	3	★
D0289	2.89	15	60	3	★
D0290	2.9	15	60	3	●
D0291	2.91	15	60	3	★
D0292	2.92	15	60	3	★
D0293	2.93	15	60	3	★
D0294	2.94	15	60	3	★
D0295	2.95	15	60	3	●
D0296	2.96	15	60	3	★
D0297	2.97	15	60	3	★
D0298	2.98	15	60	3	★
D0299	2.99	15	60	3	★
D0300	3.0	15	60	3	●
D0301	3.01	17	70	4	★
D0302	3.02	17	70	4	★
D0303	3.03	17	70	4	★
D0304	3.04	17	70	4	★
D0305	3.05	17	70	4	●
D0306	3.06	17	70	4	★
D0307	3.07	17	70	4	★
D0308	3.08	17	70	4	★
D0309	3.09	17	70	4	★

● : Stock standard
 ★ : Stock standard in Japan
 □ : Non stock, produce to order only

D200

Order Number	Dia. D1	Flute Length L3	Overall Length L1	Shank Dia. D4	Stock
VAPDSSUSD0310	3.1	17	70	4	●
D0311	3.11	17	70	4	★
D0312	3.12	17	70	4	★
D0313	3.13	17	70	4	★
D0314	3.14	17	70	4	★
D0315	3.15	17	70	4	●
D0316	3.16	17	70	4	★
D0317	3.17	17	70	4	★
D0318	3.18	17	70	4	★
D0319	3.19	17	70	4	★
D0320	3.2	17	70	4	●
D0321	3.21	17	70	4	★
D0322	3.22	17	70	4	★
D0323	3.23	17	70	4	★
D0324	3.24	17	70	4	★
D0325	3.25	17	70	4	●
D0326	3.26	17	70	4	★
D0327	3.27	17	70	4	★
D0328	3.28	17	70	4	★
D0329	3.29	17	70	4	★
D0330	3.3	19	70	4	●
D0331	3.31	19	70	4	★
D0332	3.32	19	70	4	★
D0333	3.33	19	70	4	★
D0334	3.34	19	70	4	★
D0335	3.35	19	70	4	●
D0336	3.36	19	70	4	★
D0337	3.37	19	70	4	★
D0338	3.38	19	70	4	★
D0339	3.39	19	70	4	★
D0340	3.4	19	70	4	●
D0341	3.41	19	70	4	★
D0342	3.42	19	70	4	★
D0343	3.43	19	70	4	★
D0344	3.44	19	70	4	★
D0345	3.45	19	70	4	●
D0346	3.46	19	70	4	★
D0347	3.47	19	70	4	★
D0348	3.48	19	70	4	★
D0349	3.49	19	70	4	★
D0350	3.5	19	70	4	●
D0351	3.51	19	70	4	★
D0352	3.52	19	70	4	★
D0353	3.53	19	70	4	★
D0354	3.54	19	70	4	★
D0355	3.55	19	70	4	●
D0356	3.56	19	70	4	★
D0357	3.57	19	70	4	★
D0358	3.58	19	70	4	★
D0359	3.59	19	70	4	★

Order Number	Dia. D1	Flute Length L3	Overall Length L1	Shank Dia. D4	Stock
VAPDSSUSD0360	3.6	21	70	4	●
D0361	3.61	21	70	4	★
D0362	3.62	21	70	4	★
D0363	3.63	21	70	4	★
D0364	3.64	21	70	4	★
D0365	3.65	21	70	4	●
D0366	3.66	21	70	4	★
D0367	3.67	21	70	4	★
D0368	3.68	21	70	4	★
D0369	3.69	21	70	4	★
D0370	3.7	21	70	4	●
D0371	3.71	21	70	4	★
D0372	3.72	21	70	4	★
D0373	3.73	21	70	4	★
D0374	3.74	21	70	4	★
D0375	3.75	21	70	4	●
D0376	3.76	21	70	4	★
D0377	3.77	21	70	4	★
D0378	3.78	21	70	4	★
D0379	3.79	21	70	4	★
D0380	3.8	21	70	4	●
D0381	3.81	21	70	4	★
D0382	3.82	21	70	4	★
D0383	3.83	21	70	4	★
D0384	3.84	21	70	4	★
D0385	3.85	21	70	4	●
D0386	3.86	21	70	4	★
D0387	3.87	21	70	4	★
D0388	3.88	21	70	4	★
D0389	3.89	21	70	4	★
D0390	3.9	21	70	4	●
D0391	3.91	21	70	4	★
D0392	3.92	21	70	4	★
D0393	3.93	21	70	4	★
D0394	3.94	21	70	4	★
D0395	3.95	21	70	4	●
D0396	3.96	21	70	4	★
D0397	3.97	21	70	4	★
D0398	3.98	21	70	4	★
D0399	3.99	21	70	4	★
D0400	4.0	21	70	4	●
D0405	4.05	21	80	6	●
D0410	4.1	21	80	6	●
D0415	4.15	21	80	6	●
D0420	4.2	21	80	6	●
D0425	4.25	21	80	6	●
D0430	4.3	23	80	6	●
D0435	4.35	23	80	6	●
D0440	4.4	23	80	6	●
D0445	4.45	23	80	6	●

VIOLET DRILLS



Ø 3.1~
4.45

CUTTING CONDITIONS



D210

D201

VIOLET DRILLS

VAPDSSUS



P	M	K	S	N	H
✓	✓	✓		✓	



All drills except those with intervals of 0.1mm and under dia. 4mm have a tolerance of 0--0.009mm.

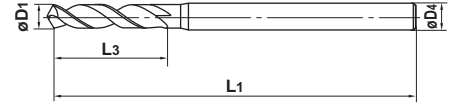

Unit : mm

Order Number	Dia. D1	Flute Length L3	Overall Length L1	Shank Dia. D4	Stock
VAPDSSUSD0450	4.5	23	80	6	●
D0455	4.55	23	80	6	●
D0460	4.6	25	80	6	●
D0465	4.65	25	80	6	●
D0470	4.7	25	80	6	●
D0475	4.75	25	80	6	●
D0480	4.8	25	80	6	●
D0485	4.85	25	80	6	●
D0490	4.9	25	80	6	●
D0495	4.95	25	80	6	●
D0500	5.0	25	80	6	●
D0505	5.05	25	80	6	●
D0510	5.1	25	80	6	●
D0515	5.15	25	80	6	●
D0520	5.2	25	80	6	●
D0525	5.25	25	80	6	●
D0530	5.3	25	80	6	●
D0535	5.35	27	80	6	●
D0540	5.4	27	80	6	●
D0545	5.45	27	80	6	●
D0550	5.5	27	80	6	●
D0555	5.55	27	80	6	●
D0560	5.6	27	80	6	●
D0565	5.65	27	80	6	●
D0570	5.7	27	80	6	●
D0575	5.75	27	80	6	●
D0580	5.8	27	80	6	●
D0585	5.85	27	80	6	●
D0590	5.9	27	80	6	●
D0595	5.95	27	80	6	●
D0600	6.0	27	80	6	●
D0605	6.05	30	80	8	●
D0610	6.1	30	80	8	●
D0615	6.15	30	80	8	●
D0620	6.2	30	80	8	●
D0625	6.25	30	80	8	●
D0630	6.3	30	80	8	●
D0635	6.35	30	80	8	●
D0640	6.4	30	80	8	●
D0645	6.45	30	80	8	●

Order Number	Dia. D1	Flute Length L3	Overall Length L1	Shank Dia. D4	Stock
VAPDSSUSD0650	6.5	30	80	8	●
D0655	6.55	30	80	8	●
D0660	6.6	30	80	8	●
D0665	6.65	30	80	8	●
D0670	6.7	30	80	8	●
D0675	6.75	32	80	8	●
D0680	6.8	32	80	8	●
D0685	6.85	32	80	8	●
D0690	6.9	32	80	8	●
D0695	6.95	32	80	8	●
D0700	7.0	32	80	8	●
D0705	7.05	32	80	8	●
D0710	7.1	32	80	8	●
D0715	7.15	32	80	8	●
D0720	7.2	32	80	8	●
D0725	7.25	32	80	8	●
D0730	7.3	32	80	8	●
D0735	7.35	32	80	8	●
D0740	7.4	32	80	8	●
D0745	7.45	32	80	8	●
D0750	7.5	32	80	8	●
D0755	7.55	35	85	8	●
D0760	7.6	35	85	8	●
D0765	7.65	35	85	8	●
D0770	7.7	35	85	8	●
D0775	7.75	35	85	8	●
D0780	7.8	35	85	8	●
D0785	7.85	35	85	8	●
D0790	7.9	35	85	8	●
D0795	7.95	35	85	8	●
D0800	8.0	35	85	8	●
D0805	8.05	35	90	10	●
D0810	8.1	35	90	10	●
D0815	8.15	35	90	10	●
D0820	8.2	35	90	10	●
D0825	8.25	35	90	10	●
D0830	8.3	35	90	10	●
D0835	8.35	35	90	10	●
D0840	8.4	35	90	10	●
D0845	8.45	35	90	10	●

VIOLET DRILLS



Ø4.5~8.45

● : Stock standard
 ★ : Stock standard in Japan
 □ : Non stock, produce to order only

Unit : mm

Order Number	Dia. D1	Flute Length L3	Overall Length L1	Shank Dia. D4	Stock
VAPDSSUSD0850	8.5	35	90	10	●
D0855	8.55	38	93	10	●
D0860	8.6	38	93	10	●
D0865	8.65	38	93	10	●
D0870	8.7	38	93	10	●
D0875	8.75	38	93	10	●
D0880	8.8	38	93	10	●
D0885	8.85	38	93	10	●
D0890	8.9	38	93	10	●
D0895	8.95	38	93	10	●
D0900	9.0	38	93	10	●
D0910	9.1	38	93	10	●
D0920	9.2	38	93	10	●
D0930	9.3	38	93	10	●
D0940	9.4	38	93	10	●
D0950	9.5	38	93	10	●
D0960	9.6	41	96	10	●
D0970	9.7	41	96	10	●
D0980	9.8	41	96	10	●
D0990	9.9	41	96	10	●
D1000	10.0	41	96	10	●
D1010	10.1	41	101	12	●
D1020	10.2	41	101	12	●
D1030	10.3	41	101	12	●
D1040	10.4	41	101	12	●
D1050	10.5	41	101	12	●
D1060	10.6	41	101	12	●
D1070	10.7	45	105	12	●
D1080	10.8	45	105	12	●
D1090	10.9	45	105	12	●
D1100	11.0	45	105	12	●
D1110	11.1	45	105	12	●
D1120	11.2	45	105	12	●
D1130	11.3	45	105	12	●
D1140	11.4	45	105	12	●
D1150	11.5	45	105	12	●
D1160	11.6	45	105	12	●
D1170	11.7	45	105	12	●
D1180	11.8	45	105	12	●
D1190	11.9	49	109	12	●
D1200	12.0	49	109	12	●
D1210	12.1	49	109	12	●
D1220	12.2	49	109	12	●
D1230	12.3	49	109	12	●
D1240	12.4	49	109	12	●
D1250	12.5	49	109	12	●
D1260	12.6	49	109	12	●
D1270	12.7	49	109	12	●
D1280	12.8	49	109	12	●
D1290	12.9	49	109	12	●

Order Number	Dia. D1	Flute Length L3	Overall Length L1	Shank Dia. D4	Stock
VAPDSSUSD1300	13.0	49	109	12	●
D1350	13.5	51	111	16	●
D1400	14.0	51	111	16	●
D1410	14.1	53	113	16	●
D1420	14.2	53	113	16	●
D1450	14.5	53	113	16	●
D1500	15.0	53	113	16	●
D1550	15.5	55	115	16	●
D1560	15.6	55	115	16	●
D1570	15.7	55	115	16	●
D1600	16.0	55	115	16	●
D1650	16.5	57	122	20	●
D1700	17.0	57	122	20	●
D1750	17.5	58	123	20	●
D1760	17.6	58	123	20	●
D1770	17.7	58	123	20	●
D1800	18.0	58	123	20	●
D1850	18.5	60	125	20	●
D1900	19.0	60	125	20	●
D1950	19.5	62	127	20	●
D1960	19.6	62	127	20	●
D1970	19.7	62	127	20	●
D2000	20.0	62	127	20	●

VIOLET SERIES, HIGH PRECISION DRILLS

VAPDS

Short flute,
High precision

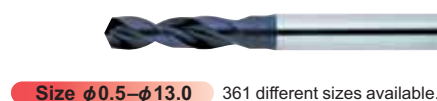

Size $\phi 0.5-\phi 13.0$ 361 different sizes available.

VAPDM

Medium flute,
High precision



Size $\phi 0.5-\phi 32.0$ 254 different sizes available.

VAPDSSUS

Short flute,
High precision,
For stainless steels



Size $\phi 0.5-\phi 20.0$ 513 different sizes available.

VAPDMSUS

Medium flute,
High precision,
For stainless steels



Size $\phi 0.5-\phi 13.0$ 491 different sizes available.

VIOLET DRILLS

DRILLING

$\phi 8.5\sim 20.0$

CUTTING CONDITIONS

D210

D203

VIOLET DRILLS

VAPDMSUS



D1<4

4≤D1

P	M	K	S	N	H
✓	✓	✓		✓	



All drills except those with intervals of 0.1mm and under dia. 4mm have tolerance of 0-- -0.009mm.

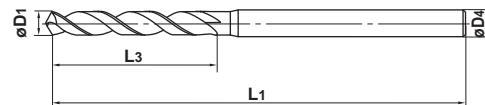

Unit : mm

Order Number	Dia. D1	Flute Length L3	Overall Length L1	Shank Dia. D4	Stock
VAPDMSUSD0050	0.5	6	50	3	●
D0051	0.51	6	50	3	★
D0052	0.52	6	50	3	★
D0053	0.53	6	50	3	★
D0054	0.54	6	50	3	★
D0055	0.55	6	50	3	★
D0056	0.56	8	50	3	★
D0057	0.57	8	50	3	★
D0058	0.58	8	50	3	★
D0059	0.59	8	50	3	★
D0060	0.6	8	50	3	●
D0061	0.61	8	50	3	★
D0062	0.62	8	50	3	★
D0063	0.63	8	50	3	★
D0064	0.64	8	50	3	★
D0065	0.65	8	50	3	★
D0066	0.66	8	50	3	★
D0067	0.67	8	50	3	★
D0068	0.68	8	50	3	★
D0069	0.69	8	50	3	★
D0070	0.7	10	50	3	●
D0071	0.71	10	50	3	★
D0072	0.72	10	50	3	★
D0073	0.73	10	50	3	★
D0074	0.74	10	50	3	★
D0075	0.75	10	50	3	★
D0076	0.76	10	50	3	★
D0077	0.77	10	50	3	★
D0078	0.78	10	50	3	★
D0079	0.79	10	50	3	★
D0080	0.8	10	50	3	●
D0081	0.81	10	50	3	★
D0082	0.82	10	50	3	★
D0083	0.83	10	50	3	★
D0084	0.84	10	50	3	★
D0085	0.85	10	50	3	★
D0086	0.86	12	50	3	★
D0087	0.87	12	50	3	★

Order Number	Dia. D1	Flute Length L3	Overall Length L1	Shank Dia. D4	Stock
VAPDMSUSD0088	0.88	12	50	3	★
D0089	0.89	12	50	3	★
D0090	0.9	12	50	3	●
D0091	0.91	12	50	3	★
D0092	0.92	12	50	3	★
D0093	0.93	12	50	3	★
D0094	0.94	12	50	3	★
D0095	0.95	12	50	3	★
D0096	0.96	12	50	3	★
D0097	0.97	12	50	3	★
D0098	0.98	12	50	3	★
D0099	0.99	12	50	3	★
D0100	1.0	12	60	3	●
D0101	1.01	12	60	3	★
D0102	1.02	12	60	3	★
D0103	1.03	12	60	3	★
D0104	1.04	12	60	3	★
D0105	1.05	12	60	3	★
D0106	1.06	12	60	3	★
D0107	1.07	16	60	3	★
D0108	1.08	16	60	3	★
D0109	1.09	16	60	3	★
D0110	1.1	16	60	3	●
D0111	1.11	16	60	3	★
D0112	1.12	16	60	3	★
D0113	1.13	16	60	3	★
D0114	1.14	16	60	3	★
D0115	1.15	16	60	3	★
D0116	1.16	16	60	3	★
D0117	1.17	16	60	3	★
D0118	1.18	16	60	3	★
D0119	1.19	16	60	3	★
D0120	1.2	16	60	3	●
D0121	1.21	16	60	3	★
D0122	1.22	16	60	3	★
D0123	1.23	16	60	3	★
D0124	1.24	16	60	3	★
D0125	1.25	16	60	3	★

VIOLET DRILLS

DRILLING

Ø0.5~1.25

● : Stock standard
 ★ : Stock standard in Japan
 □ : Non stock, produce to order only

Unit : mm

Order Number	Dia. D1	Flute Length L3	Overall Length L1	Shank Dia. D4	Stock
VAPDMSUSD0126	1.26	16	60	3	★
D0127	1.27	16	60	3	★
D0128	1.28	16	60	3	★
D0129	1.29	16	60	3	★
D0130	1.3	16	60	3	●
D0131	1.31	18	60	3	★
D0132	1.32	18	60	3	★
D0133	1.33	18	60	3	★
D0134	1.34	18	60	3	★
D0135	1.35	18	60	3	★
D0136	1.36	18	60	3	★
D0137	1.37	18	60	3	★
D0138	1.38	18	60	3	★
D0139	1.39	18	60	3	★
D0140	1.4	18	60	3	●
D0141	1.41	18	60	3	★
D0142	1.42	18	60	3	★
D0143	1.43	18	60	3	★
D0144	1.44	18	60	3	★
D0145	1.45	18	60	3	★
D0146	1.46	18	60	3	★
D0147	1.47	18	60	3	★
D0148	1.48	18	60	3	★
D0149	1.49	18	60	3	★
D0150	1.5	18	60	3	●
D0151	1.51	20	60	3	★
D0152	1.52	20	60	3	★
D0153	1.53	20	60	3	★
D0154	1.54	20	60	3	★
D0155	1.55	20	60	3	★
D0156	1.56	20	60	3	★
D0157	1.57	20	60	3	★
D0158	1.58	20	60	3	★
D0159	1.59	20	60	3	★
D0160	1.6	20	60	3	●
D0161	1.61	20	60	3	★
D0162	1.62	20	60	3	★
D0163	1.63	20	60	3	★
D0164	1.64	20	60	3	★
D0165	1.65	20	60	3	★
D0166	1.66	20	60	3	★
D0167	1.67	20	60	3	★
D0168	1.68	20	60	3	★
D0169	1.69	20	60	3	★
D0170	1.7	20	60	3	●
D0171	1.71	20	60	3	★
D0172	1.72	20	60	3	★
D0173	1.73	20	60	3	★

Order Number	Dia. D1	Flute Length L3	Overall Length L1	Shank Dia. D4	Stock
VAPDMSUSD0174	1.74	20	60	3	★
D0175	1.75	20	60	3	★
D0176	1.76	20	60	3	★
D0177	1.77	20	60	3	★
D0178	1.78	20	60	3	★
D0179	1.79	20	60	3	★
D0180	1.8	22	60	3	●
D0181	1.81	22	60	3	★
D0182	1.82	22	60	3	★
D0183	1.83	22	60	3	★
D0184	1.84	22	60	3	★
D0185	1.85	22	60	3	★
D0186	1.86	22	60	3	★
D0187	1.87	22	60	3	★
D0188	1.88	22	60	3	★
D0189	1.89	22	60	3	★
D0190	1.9	22	60	3	●
D0191	1.91	23	60	3	★
D0192	1.92	23	60	3	★
D0193	1.93	23	60	3	★
D0194	1.94	23	60	3	★
D0195	1.95	23	60	3	★
D0196	1.96	23	60	3	★
D0197	1.97	23	60	3	★
D0198	1.98	23	60	3	★
D0199	1.99	23	60	3	★
D0200	2.0	23	70	3	●
D0201	2.01	23	70	3	★
D0202	2.02	23	70	3	★
D0203	2.03	23	70	3	★
D0204	2.04	23	70	3	★
D0205	2.05	23	70	3	★
D0206	2.06	23	70	3	★
D0207	2.07	23	70	3	★
D0208	2.08	23	70	3	★
D0209	2.09	23	70	3	★
D0210	2.1	23	70	3	●
D0211	2.11	23	70	3	★
D0212	2.12	23	70	3	★
D0213	2.13	23	70	3	★
D0214	2.14	23	70	3	★
D0215	2.15	23	70	3	★
D0216	2.16	23	70	3	★
D0217	2.17	23	70	3	★
D0218	2.18	23	70	3	★
D0219	2.19	23	70	3	★
D0220	2.2	26	70	3	●
D0221	2.21	26	70	3	★

VIOLET DRILLS

DRILLING

Ø 1.26~
2.21

CUTTING CONDITIONS

D210

D205

VIOLET DRILLS

VAPDMSUS



All drills except those with intervals of 0.1mm and under dia. 4mm have tolerance of 0-- -0.009mm.

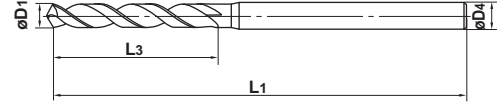

Unit : mm

Order Number	Dia. D1	Flute Length L3	Overall Length L1	Shank Dia. D4	Stock
VAPDMSUSD0222	2.22	26	70	3	★
D0223	2.23	26	70	3	★
D0224	2.24	26	70	3	★
D0225	2.25	26	70	3	★
D0226	2.26	26	70	3	★
D0227	2.27	26	70	3	★
D0228	2.28	26	70	3	★
D0229	2.29	26	70	3	★
D0230	2.3	26	70	3	●
D0231	2.31	26	70	3	★
D0232	2.32	26	70	3	★
D0233	2.33	26	70	3	★
D0234	2.34	26	70	3	★
D0235	2.35	26	70	3	★
D0236	2.36	26	70	3	★
D0237	2.37	26	70	3	★
D0238	2.38	26	70	3	★
D0239	2.39	26	70	3	★
D0240	2.4	29	70	3	●
D0241	2.41	29	70	3	★
D0242	2.42	29	70	3	★
D0243	2.43	29	70	3	★
D0244	2.44	29	70	3	★
D0245	2.45	29	70	3	★
D0246	2.46	29	70	3	★
D0247	2.47	29	70	3	★
D0248	2.48	29	70	3	★
D0249	2.49	29	70	3	★
D0250	2.5	29	70	3	●
D0251	2.51	29	70	3	★
D0252	2.52	29	70	3	★
D0253	2.53	29	70	3	★
D0254	2.54	29	70	3	★
D0255	2.55	29	70	3	★
D0256	2.56	29	70	3	★
D0257	2.57	29	70	3	★
D0258	2.58	29	70	3	★
D0259	2.59	29	70	3	★

Order Number	Dia. D1	Flute Length L3	Overall Length L1	Shank Dia. D4	Stock
VAPDMSUSD0260	2.6	29	70	3	●
D0261	2.61	29	70	3	★
D0262	2.62	29	70	3	★
D0263	2.63	29	70	3	★
D0264	2.64	29	70	3	★
D0265	2.65	29	70	3	★
D0266	2.66	29	70	3	★
D0267	2.67	29	70	3	★
D0268	2.68	29	70	3	★
D0269	2.69	29	70	3	★
D0270	2.7	32	70	3	●
D0271	2.71	32	70	3	★
D0272	2.72	32	70	3	★
D0273	2.73	32	70	3	★
D0274	2.74	32	70	3	★
D0275	2.75	32	70	3	★
D0276	2.76	32	70	3	★
D0277	2.77	32	70	3	★
D0278	2.78	32	70	3	★
D0279	2.79	32	70	3	★
D0280	2.8	32	70	3	●
D0281	2.81	32	70	3	★
D0282	2.82	32	70	3	★
D0283	2.83	32	70	3	★
D0284	2.84	32	70	3	★
D0285	2.85	32	70	3	★
D0286	2.86	32	70	3	★
D0287	2.87	32	70	3	★
D0288	2.88	32	70	3	★
D0289	2.89	32	70	3	★
D0290	2.9	32	70	3	●
D0291	2.91	32	70	3	★
D0292	2.92	32	70	3	★
D0293	2.93	32	70	3	★
D0294	2.94	32	70	3	★
D0295	2.95	32	70	3	★
D0296	2.96	32	70	3	★
D0297	2.97	32	70	3	★

DRILLING VIOLET DRILLS



Ø2.22~2.97

● : Stock standard
 ★ : Stock standard in Japan
 □ : Non stock, produce to order only

Unit : mm

Order Number	Dia. D1	Flute Length L3	Overall Length L1	Shank Dia. D4	Stock
VAPDMSUSD0298	2.98	32	70	3	★
D0299	2.99	32	70	3	★
D0300	3.0	32	70	3	●
D0301	3.01	35	85	4	★
D0302	3.02	35	85	4	★
D0303	3.03	35	85	4	★
D0304	3.04	35	85	4	★
D0305	3.05	35	85	4	★
D0306	3.06	35	85	4	★
D0307	3.07	35	85	4	★
D0308	3.08	35	85	4	★
D0309	3.09	35	85	4	★
D0310	3.1	35	85	4	●
D0311	3.11	35	85	4	★
D0312	3.12	35	85	4	★
D0313	3.13	35	85	4	★
D0314	3.14	35	85	4	★
D0315	3.15	35	85	4	★
D0316	3.16	35	85	4	★
D0317	3.17	35	85	4	★
D0318	3.18	35	85	4	★
D0319	3.19	35	85	4	★
D0320	3.2	35	85	4	●
D0321	3.21	35	85	4	★
D0322	3.22	35	85	4	★
D0323	3.23	35	85	4	★
D0324	3.24	35	85	4	★
D0325	3.25	35	85	4	★
D0326	3.26	35	85	4	★
D0327	3.27	35	85	4	★
D0328	3.28	35	85	4	★
D0329	3.29	35	85	4	★
D0330	3.3	35	85	4	●
D0331	3.31	38	85	4	★
D0332	3.32	38	85	4	★
D0333	3.33	38	85	4	★
D0334	3.34	38	85	4	★
D0335	3.35	38	85	4	★
D0336	3.36	38	85	4	★
D0337	3.37	38	85	4	★
D0338	3.38	38	85	4	★
D0339	3.39	38	85	4	★
D0340	3.4	38	85	4	●
D0341	3.41	38	85	4	★
D0342	3.42	38	85	4	★
D0343	3.43	38	85	4	★
D0344	3.44	38	85	4	★
D0345	3.45	38	85	4	★

Order Number	Dia. D1	Flute Length L3	Overall Length L1	Shank Dia. D4	Stock
VAPDMSUSD0346	3.46	38	85	4	★
D0347	3.47	38	85	4	★
D0348	3.48	38	85	4	★
D0349	3.49	38	85	4	★
D0350	3.5	38	85	4	●
D0351	3.51	38	85	4	★
D0352	3.52	38	85	4	★
D0353	3.53	38	85	4	★
D0354	3.54	38	85	4	★
D0355	3.55	38	85	4	★
D0356	3.56	38	85	4	★
D0357	3.57	38	85	4	★
D0358	3.58	38	85	4	★
D0359	3.59	38	85	4	★
D0360	3.6	38	85	4	●
D0361	3.61	38	85	4	★
D0362	3.62	38	85	4	★
D0363	3.63	38	85	4	★
D0364	3.64	38	85	4	★
D0365	3.65	38	85	4	★
D0366	3.66	38	85	4	★
D0367	3.67	38	85	4	★
D0368	3.68	38	85	4	★
D0369	3.69	38	85	4	★
D0370	3.7	38	85	4	●
D0371	3.71	42	85	4	★
D0372	3.72	42	85	4	★
D0373	3.73	42	85	4	★
D0374	3.74	42	85	4	★
D0375	3.75	42	85	4	★
D0376	3.76	42	85	4	★
D0377	3.77	42	85	4	★
D0378	3.78	42	85	4	★
D0379	3.79	42	85	4	★
D0380	3.8	42	85	4	●
D0381	3.81	42	85	4	★
D0382	3.82	42	85	4	★
D0383	3.83	42	85	4	★
D0384	3.84	42	85	4	★
D0385	3.85	42	85	4	★
D0386	3.86	42	85	4	★
D0387	3.87	42	85	4	★
D0388	3.88	42	85	4	★
D0389	3.89	42	85	4	★
D0390	3.9	42	85	4	●
D0391	3.91	42	85	4	★
D0392	3.92	42	85	4	★
D0393	3.93	42	85	4	★

VIOLET DRILLS



DRILLING
 Ø 2.98~
 3.93

CUTTING CONDITIONS

D210

D207

VIOLET DRILLS

VAPDMSUS



All drills except those with intervals of 0.1mm and under dia. 4mm have tolerance of 0-- -0.009mm.

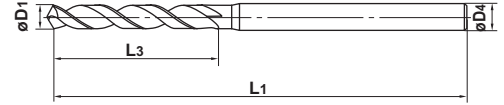

Unit : mm

Order Number	Dia. D1	Flute Length L3	Overall Length L1	Shank Dia. D4	Stock
VAPDMSUSD0394	3.94	42	85	4	★
D0395	3.95	42	85	4	★
D0396	3.96	42	85	4	★
D0397	3.97	42	85	4	★
D0398	3.98	42	85	4	★
D0399	3.99	42	85	4	★
D0400	4.0	42	85	4	●
D0405	4.05	42	100	6	★
D0410	4.1	42	100	6	●
D0415	4.15	42	100	6	★
D0420	4.2	42	100	6	●
D0425	4.25	46	100	6	★
D0430	4.3	46	100	6	●
D0435	4.35	46	100	6	★
D0440	4.4	46	100	6	●
D0445	4.45	46	100	6	★
D0450	4.5	46	100	6	●
D0455	4.55	46	100	6	★
D0460	4.6	46	100	6	●
D0465	4.65	46	100	6	★
D0470	4.7	46	100	6	●
D0475	4.75	46	100	6	★
D0480	4.8	51	100	6	●
D0485	4.85	51	100	6	★
D0490	4.9	51	100	6	●
D0495	4.95	51	100	6	★
D0500	5.0	51	100	6	●
D0505	5.05	51	100	6	★
D0510	5.1	51	100	6	●
D0515	5.15	51	100	6	★
D0520	5.2	51	100	6	●
D0525	5.25	51	100	6	★
D0530	5.3	51	100	6	●
D0535	5.35	56	106	6	★
D0540	5.4	56	106	6	●
D0545	5.45	56	106	6	★
D0550	5.5	56	106	6	●
D0555	5.55	56	106	6	★

Order Number	Dia. D1	Flute Length L3	Overall Length L1	Shank Dia. D4	Stock
VAPDMSUSD0560	5.6	56	106	6	●
D0565	5.65	56	106	6	★
D0570	5.7	56	106	6	●
D0575	5.75	56	106	6	★
D0580	5.8	56	106	6	●
D0585	5.85	56	106	6	★
D0590	5.9	56	106	6	●
D0595	5.95	56	106	6	★
D0600	6.0	56	106	6	●
D0605	6.05	62	112	8	★
D0610	6.1	62	112	8	●
D0615	6.15	62	112	8	★
D0620	6.2	62	112	8	●
D0625	6.25	62	112	8	★
D0630	6.3	62	112	8	●
D0635	6.35	62	112	8	★
D0640	6.4	62	112	8	●
D0645	6.45	62	112	8	★
D0650	6.5	62	112	8	●
D0655	6.55	62	112	8	★
D0660	6.6	62	112	8	●
D0665	6.65	62	112	8	★
D0670	6.7	62	112	8	●
D0675	6.75	67	117	8	★
D0680	6.8	67	117	8	●
D0685	6.85	67	117	8	★
D0690	6.9	67	117	8	●
D0695	6.95	67	117	8	★
D0700	7.0	67	117	8	●
D0705	7.05	67	117	8	★
D0710	7.1	67	117	8	●
D0715	7.15	67	117	8	★
D0720	7.2	67	117	8	●
D0725	7.25	67	117	8	★
D0730	7.3	67	117	8	●
D0735	7.35	67	117	8	★
D0740	7.4	67	117	8	●
D0745	7.45	67	117	8	★

VIOLET DRILLS

DRILLING

Ø3.94~7.45

● : Stock standard
 ★ : Stock standard in Japan
 □ : Non stock, produce to order only

Unit : mm

Order Number	Dia. D1	Flute Length L3	Overall Length L1	Shank Dia. D4	Stock
VAPDMSUSD0750	7.5	67	117	8	●
D0755	7.55	73	123	8	★
D0760	7.6	73	123	8	●
D0765	7.65	73	123	8	★
D0770	7.7	73	123	8	●
D0775	7.75	73	123	8	★
D0780	7.8	73	123	8	●
D0785	7.85	73	123	8	★
D0790	7.9	73	123	8	●
D0795	7.95	73	123	8	★
D0800	8.0	73	123	8	●
D0805	8.05	73	128	10	★
D0810	8.1	73	128	10	●
D0815	8.15	73	128	10	★
D0820	8.2	73	128	10	●
D0825	8.25	73	128	10	★
D0830	8.3	73	128	10	●
D0835	8.35	73	128	10	★
D0840	8.4	73	128	10	●
D0845	8.45	73	128	10	★
D0850	8.5	73	128	10	●
D0855	8.55	79	134	10	★
D0860	8.6	79	134	10	●
D0865	8.65	79	134	10	★
D0870	8.7	79	134	10	●
D0875	8.75	79	134	10	★
D0880	8.8	79	134	10	●
D0885	8.85	79	134	10	★
D0890	8.9	79	134	10	●
D0895	8.95	79	134	10	★
D0900	9.0	79	134	10	●
D0910	9.1	79	134	10	●
D0920	9.2	79	134	10	●
D0930	9.3	79	134	10	●
D0940	9.4	79	134	10	●
D0950	9.5	79	134	10	●
D0960	9.6	85	140	10	●
D0970	9.7	85	140	10	●
D0980	9.8	85	140	10	●
D0990	9.9	85	140	10	●
D1000	10.0	85	140	10	●
D1010	10.1	85	145	12	●
D1020	10.2	85	145	12	●
D1030	10.3	85	145	12	●
D1040	10.4	85	145	12	●
D1050	10.5	85	145	12	●
D1060	10.6	85	145	12	●
D1070	10.7	92	152	12	●

Order Number	Dia. D1	Flute Length L3	Overall Length L1	Shank Dia. D4	Stock
VAPDMSUSD1080	10.8	92	152	12	●
D1090	10.9	92	152	12	●
D1100	11.0	92	152	12	●
D1110	11.1	92	152	12	●
D1120	11.2	92	152	12	●
D1130	11.3	92	152	12	●
D1140	11.4	92	152	12	●
D1150	11.5	92	152	12	●
D1160	11.6	92	152	12	●
D1170	11.7	92	152	12	●
D1180	11.8	92	152	12	●
D1190	11.9	99	159	12	●
D1200	12.0	99	159	12	●
D1210	12.1	99	159	12	●
D1220	12.2	99	159	12	●
D1230	12.3	99	159	12	●
D1240	12.4	99	159	12	●
D1250	12.5	99	159	12	●
D1260	12.6	99	159	12	●
D1270	12.7	99	159	12	●
D1280	12.8	99	159	12	●
D1290	12.9	99	159	12	●
D1300	13.0	99	159	12	●

VIOLET DRILLS

Ø 7.5~
13.0

CUTTING CONDITIONS

D210

D209

VIOLET DRILLS

VAPDSSUS VAPDMSUS

VIOLET DRILLS, High precision, For stainless steel, Short/Medium flute length



VAPDSSUS, VAPDMSUS

Work material	Stainless steel				Carbon steel Cf53 Alloy steel 070M55 Cast iron Copper, Copper alloy		Structural steel Aluminium alloy	
	Austenitic X5CrNi1810 X5CrNiMo17122		Martensitic Ferritic X10CrA118		Revolution (min ⁻¹)	Feed rate (mm/rev)	Revolution (min ⁻¹)	Feed rate (mm/rev)
Dia. (mm)	Revolution (min ⁻¹)	Feed rate (mm/rev)	Revolution (min ⁻¹)	Feed rate (mm/rev)	Revolution (min ⁻¹)	Feed rate (mm/rev)	Revolution (min ⁻¹)	Feed rate (mm/rev)
0.5	7,600	0.01	8,800	0.01	11,250	0.01	15,000	0.02
1.0	4,800	0.02	6,300	0.05	10,000	0.05	12,000	0.05
2.0	2,400	0.04	3,200	0.06	5,500	0.09	6,400	0.09
3.0	1,600	0.07	2,100	0.10	3,700	0.13	4,300	0.13
4.0	1,200	0.09	1,600	0.10	2,800	0.15	3,200	0.15
5.0	950	0.12	1,300	0.13	2,200	0.18	2,600	0.18
6.0	800	0.14	1,100	0.15	1,800	0.20	2,100	0.19
8.0	600	0.18	800	0.18	1,400	0.22	1,600	0.24
10.0	480	0.22	640	0.21	1,100	0.25	1,300	0.28
12.0	400	0.24	530	0.25	930	0.30	1,100	0.34
13.0	370	0.26	490	0.28	860	0.32	1,000	0.36
14.0	340	0.30	450	0.27	730	0.31	930	0.36
15.0	320	0.31	425	0.28	680	0.32	870	0.38
16.0	300	0.32	400	0.30	640	0.34	820	0.42
18.0	270	0.34	350	0.32	570	0.36	725	0.43
20.0	240	0.36	320	0.35	510	0.38	660	0.45

- 1) Please reduce the revolution and feed rate when the workpiece clamping lacks rigidity or the machine has limitations.
- 2) Please use a collet type drill chuck.
- 3) Use sufficient cutting fluid.
- 4) Do not peck drill and reduce the cutting conditions when drilling depths exceed 3×D (D : drill diameter).

The above mentioned cutting conditions are standard when using water soluble cutting fluid.
Please reduce the revolutions when using non-water soluble cutting fluid.

VIOLET DRILLS



CUTTING DATA

VIOLET DRILLS

VEUSM

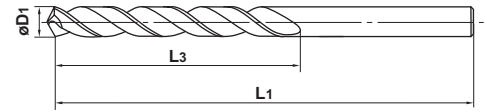

Unit : mm

Order Number	Dia. D1	Flute Length L3	Overall Length L1	Stock
VEUSMD0100	1.0	12	40	●
D0110	1.1	16	42	●
D0120	1.2	16	42	●
D0130	1.3	16	45	●
D0140	1.4	18	48	●
D0150	1.5	18	48	●
D0160	1.6	19	50	●
D0170	1.7	19	50	●
D0180	1.8	21	52	●
D0190	1.9	21	52	●
D0200	2.0	23	55	●
D0210	2.1	23	55	●
D0220	2.2	26	58	●
D0230	2.3	26	58	●
D0240	2.4	29	61	●
D0250	2.5	29	61	●
D0260	2.6	29	64	●
D0270	2.7	32	64	●
D0280	2.8	32	67	●
D0290	2.9	32	71	●
D0300	3.0	32	71	●
D0310	3.1	35	71	●
D0320	3.2	35	71	●
D0330	3.3	35	73	●
D0340	3.4	38	73	●
D0350	3.5	38	73	●
D0360	3.6	38	76	●
D0370	3.7	38	76	●
D0380	3.8	42	76	●
D0390	3.9	42	79	●
D0400	4.0	42	83	●
D0410	4.1	42	83	●
D0420	4.2	42	83	●
D0430	4.3	46	83	●
D0440	4.4	46	86	●
D0450	4.5	46	86	●
D0460	4.6	46	86	●
D0470	4.7	46	89	●

Order Number	Dia. D1	Flute Length L3	Overall Length L1	Stock
VEUSMD0480	4.8	50	89	●
D0490	4.9	50	92	●
D0500	5.0	50	92	●
D0510	5.1	50	92	●
D0520	5.2	50	95	●
D0530	5.3	50	95	●
D0540	5.4	55	95	●
D0550	5.5	55	95	●
D0560	5.6	55	98	●
D0570	5.7	55	98	●
D0580	5.8	55	98	●
D0590	5.9	55	98	●
D0600	6.0	55	102	●
D0610	6.1	61	102	●
D0620	6.2	61	102	●
D0630	6.3	61	102	●
D0640	6.4	61	105	●
D0650	6.5	61	105	●
D0660	6.6	61	105	●
D0670	6.7	61	105	●
D0680	6.8	67	105	●
D0690	6.9	67	105	●
D0700	7.0	67	105	●
D0710	7.1	67	108	●
D0720	7.2	67	108	●
D0730	7.3	67	108	●
D0740	7.4	67	111	●
D0750	7.5	67	111	●
D0760	7.6	72	111	●
D0770	7.7	72	114	●
D0780	7.8	72	114	●
D0790	7.9	72	114	●
D0800	8.0	72	114	●
D0810	8.1	72	117	●
D0820	8.2	72	117	●
D0830	8.3	72	117	●
D0840	8.4	72	121	●
D0850	8.5	72	121	●

VIOLET DRILLS



Ø 1.0~8.5

● : Stock standard
 ★ : Stock standard in Japan
 □ : Non stock, produce to order only

CUTTING CONDITIONS



D211

VIOLET DRILLS

VEUSM

VIOLET DRILLS, For stainless steel

Unit : mm

Order Number	Dia. D1	Flute Length L3	Overall Length L1	Stock
VEUSMD0860	8.6	78	121	●
D0870	8.7	78	121	●
D0880	8.8	78	124	●
D0890	8.9	78	124	●
D0900	9.0	78	124	●
D0910	9.1	78	124	●
D0920	9.2	78	127	●
D0930	9.3	78	127	●
D0940	9.4	78	127	●
D0950	9.5	78	127	●
D0960	9.6	84	130	●
D0970	9.7	84	130	●
D0980	9.8	84	130	●
D0990	9.9	84	130	●
D1000	10.0	84	130	●
D1010	10.1	84	133	●
D1020	10.2	84	133	●
D1030	10.3	84	133	●
D1040	10.4	84	133	●
D1050	10.5	84	137	●
D1060	10.6	84	137	●
D1070	10.7	90	137	●
D1080	10.8	90	140	●
D1090	10.9	90	140	●
D1100	11.0	90	140	●
D1110	11.1	90	140	●
D1120	11.2	90	143	●
D1130	11.3	90	143	●
D1140	11.4	90	143	●
D1150	11.5	90	143	●
D1160	11.6	90	146	●
D1170	11.7	90	146	●
D1180	11.8	90	146	●
D1190	11.9	97	146	●
D1200	12.0	97	149	●
D1210	12.1	97	149	●
D1220	12.2	97	149	●
D1230	12.3	97	149	●
D1240	12.4	97	152	●
D1250	12.5	97	152	●
D1260	12.6	97	152	●
D1270	12.7	97	152	●
D1280	12.8	97	152	●
D1290	12.9	97	152	●
D1300	13.0	97	152	●

VIOLET DRILLS

DRILLING

Ø8.6~
13.0

RECOMMENDED CUTTING CONDITIONS

Work material	Stainless steel				Carbon steel Cf53 Alloy steel 070M55 Cast iron Copper, Copper alloy	Structural steel Aluminium alloy		
	Austenitic X5CrNi1810 X5CrNiMo17122		Martensitic Ferritic X10CrA118			Revolution (min ⁻¹)	Feed rate (mm/rev)	
Dia. (mm)	Revolution (min ⁻¹)	Feed rate (mm/rev)	Revolution (min ⁻¹)	Feed rate (mm/rev)	Revolution (min ⁻¹)	Feed rate (mm/rev)	Revolution (min ⁻¹)	Feed rate (mm/rev)
1.0	3,800	0.02	6,300	0.02	7,600	0.03	10,000	0.03
2.0	2,400	0.04	3,200	0.05	4,800	0.05	6,400	0.06
3.0	1,600	0.06	2,100	0.07	3,200	0.08	4,300	0.09
4.0	1,200	0.08	1,600	0.09	2,400	0.10	3,200	0.12
5.0	960	0.10	1,300	0.12	1,900	0.13	2,600	0.15
6.0	800	0.12	1,100	0.14	1,600	0.16	2,100	0.18
8.0	600	0.14	800	0.17	1,200	0.19	1,600	0.22
10.0	480	0.17	640	0.20	960	0.22	1,300	0.26
12.0	400	0.19	530	0.22	800	0.25	1,100	0.29
13.0	370	0.22	490	0.25	740	0.28	1,000	0.32

- 1) Please reduce the revolution and feed rate when the workpiece clamping lacks rigidity or the machine has limitations.
- 2) When drilling deep holes, lower the cutting conditions.
- 3) The above mentioned cutting conditions are standard when using water soluble cutting fluid.

VIOLET DRILLS

VSD



D1<0.7

0.7≤D1

D1<2

2≤D1

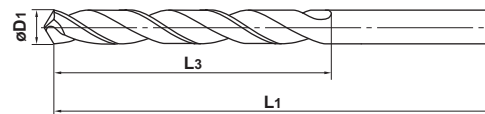

Unit : mm

Order Number	Dia. D1	Flute Length L3	Overall Length L1	Stock
VSDD0050	0.5	6	27	●
D0060	0.6	7	30	●
D0070	0.7	9	32	●
D0080	0.8	10	34	●
D0090	0.9	11	36	●
D0100	1.0	12	40	●
D0110	1.1	14	42	●
D0120	1.2	16	42	●
D0130	1.3	16	45	●
D0140	1.4	18	48	●
D0150	1.5	18	48	●
D0160	1.6	20	50	●
D0170	1.7	20	50	●
D0180	1.8	22	52	●
D0190	1.9	22	52	●
D0200	2.0	23	55	●
D0210	2.1	23	55	●
D0220	2.2	26	58	●
D0230	2.3	26	58	●
D0240	2.4	29	61	●
D0250	2.5	29	61	●
D0260	2.6	29	64	●
D0270	2.7	32	64	●
D0280	2.8	32	67	●
D0290	2.9	32	71	●
D0300	3.0	32	71	●
D0310	3.1	35	71	●
D0320	3.2	35	71	●
D0330	3.3	35	73	●
D0340	3.4	38	73	●
D0350	3.5	38	73	●
D0360	3.6	38	76	●
D0370	3.7	38	76	●
D0380	3.8	42	76	●
D0390	3.9	42	79	●
D0400	4.0	42	83	●
D0410	4.1	42	83	●
D0420	4.2	42	83	●

Order Number	Dia. D1	Flute Length L3	Overall Length L1	Stock
VSDD0430	4.3	46	83	●
D0440	4.4	46	86	●
D0450	4.5	46	86	●
D0460	4.6	46	86	●
D0470	4.7	46	89	●
D0480	4.8	51	89	●
D0490	4.9	51	92	●
D0500	5.0	51	92	●
D0510	5.1	51	92	●
D0520	5.2	51	95	●
D0530	5.3	51	95	●
D0540	5.4	56	95	●
D0550	5.5	56	95	●
D0560	5.6	56	98	●
D0570	5.7	56	98	●
D0580	5.8	56	98	●
D0590	5.9	56	98	●
D0600	6.0	56	102	●
D0610	6.1	62	102	●
D0620	6.2	62	102	●
D0630	6.3	62	102	●
D0640	6.4	62	105	●
D0650	6.5	62	105	●
D0660	6.6	62	105	●
D0670	6.7	62	105	●
D0680	6.8	67	105	●
D0690	6.9	67	105	●
D0700	7.0	67	105	●
D0710	7.1	67	108	●
D0720	7.2	67	108	●
D0730	7.3	67	108	●
D0740	7.4	67	111	●
D0750	7.5	67	111	●
D0760	7.6	73	111	●
D0770	7.7	73	114	●
D0780	7.8	73	114	●
D0790	7.9	73	114	●
D0800	8.0	73	114	●

VIOLET DRILLS



Ø0.50~8.0

● : Stock standard
 ★ : Stock standard in Japan
 □ : Non stock, produce to order only

Unit : mm

Order Number	Dia. D1	Flute Length L3	Overall Length L1	Stock
VSDD0810	8.1	73	117	●
D0820	8.2	73	117	●
D0830	8.3	73	117	●
D0840	8.4	73	121	●
D0850	8.5	73	121	●
D0860	8.6	79	121	●
D0870	8.7	79	121	●
D0880	8.8	79	124	●
D0890	8.9	79	124	●
D0900	9.0	79	124	●
D0910	9.1	79	124	●
D0920	9.2	79	127	●
D0930	9.3	79	127	●
D0940	9.4	79	127	●
D0950	9.5	79	127	●
D0960	9.6	85	130	●
D0970	9.7	85	130	●
D0980	9.8	85	130	●
D0990	9.9	85	130	●
D1000	10.0	85	130	●
D1010	10.1	85	133	●
D1020	10.2	85	133	●
D1030	10.3	85	133	●
D1040	10.4	85	133	●
D1050	10.5	85	137	●
D1060	10.6	85	137	●
D1070	10.7	92	137	●
D1080	10.8	92	140	●
D1090	10.9	92	140	●
D1100	11.0	92	140	●
D1110	11.1	92	140	●
D1120	11.2	92	143	●
D1130	11.3	92	143	●
D1140	11.4	92	143	●
D1150	11.5	92	143	●
D1160	11.6	92	146	●
D1170	11.7	92	146	●
D1180	11.8	92	146	●
D1190	11.9	99	146	●
D1200	12.0	99	149	●
D1210	12.1	99	149	●
D1220	12.2	99	149	●
D1230	12.3	99	149	●
D1240	12.4	99	152	●
D1250	12.5	99	152	●
D1260	12.6	99	152	●
D1270	12.7	99	152	●
D1280	12.8	99	152	●

Order Number	Dia. D1	Flute Length L3	Overall Length L1	Stock
VSDD1290	12.9	99	152	●
D1300	13.0	99	152	●

VIOLET DRILLS

Ø 8.1~
13.0

CUTTING CONDITIONS



D216

D215

VIOLET DRILLS

VSD

VIOLET DRILLS, Straight shank

VSD

Work material	Structural steel		Carbon steel Ck55		Stainless steel X20Cr13		Stainless steel X5CrNi1810 Tool steel X210Cr12 (Low-hardness materials) Heat-treated steel W.Nr. 1.2344(H13) (- 40HRC)	
Cutting speed	40m/min		30m/min		20m/min		10– 14m/min	
Dia. (mm)	Revolution (min ⁻¹)	Feed rate (mm/rev)	Revolution (min ⁻¹)	Feed rate (mm/rev)	Revolution (min ⁻¹)	Feed rate (mm/rev)	Revolution (min ⁻¹)	Feed rate (mm/rev)
0.5	15,000	0.01	11,250	0.01	7,500	0.01	5,620	0.01
1.0	10,000	0.02	7,500	0.02	5,000	0.02	3,750	0.02
1.5	8,200	0.03	6,150	0.03	4,100	0.03	2,800	0.03
2.0	6,370	0.05	4,780	0.05	3,180	0.05	2,200	0.04
3.0	4,250	0.10	3,180	0.10	2,120	0.07	1,400	0.06
4.0	3,180	0.13	2,390	0.13	1,590	0.09	1,100	0.08
5.0	2,550	0.15	1,910	0.15	1,270	0.11	860	0.10
6.0	2,120	0.18	1,590	0.18	1,060	0.13	720	0.11
7.0	1,820	0.20	1,360	0.20	910	0.14	610	0.12
8.0	1,590	0.22	1,190	0.21	800	0.15	540	0.13
9.0	1,420	0.24	1,060	0.22	710	0.17	480	0.14
10.0	1,270	0.26	960	0.23	640	0.18	430	0.15
11.0	1,160	0.28	870	0.24	580	0.19	390	0.16
12.0	1,060	0.30	800	0.25	530	0.20	360	0.17
13.0	980	0.30	730	0.26	490	0.20	330	0.17

- 1) Please reduce the revolutions when the workpiece clamping lacks rigidity.
- 2) Do not peck drill and reduce the cutting conditions when drilling depths exceed 3×D (D : drill diameter).
- 3) The above-mentioned cutting conditions are standard when using water-soluble cutting fluid.
Please reduce the revolutions when using non-water-soluble cutting fluid.

VIOLET DRILLS



CUTTING DATA



VAPDSCB

Innovative cutting edge geometry!
For high performance counter boring.



PRECISION
FOR SUCCESS

CHOOSE JAPAN'S NO. 1

MITSUBISHI
MITSUBISHI MATERIALS

www.mitsubishicarbide.com

Violet Series, High Precision Drills for Counter Boring

VAPDSCB

Features

Special point geometry for excellent chip breaking

Thinning geometry

Unique thinning geometry is employed to offer excellent chip breaking.

High precision flat surface

Can obtain the same level of flatness (under 0.05mm) as that of conventional counter boring tools.

Centre cutting edge

Ensures stable, high feed machining.

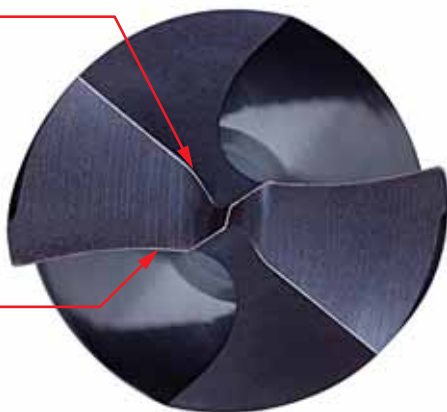

Process consolidation for drilling of flat bottom holes

Ideal chip geometry

VAPDSCB
DRILLING

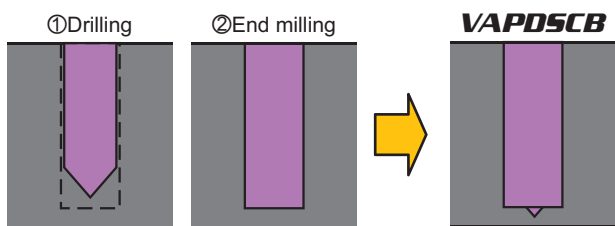

Conventional cutting method

Possible to machine 3xD hole depths with continuous feed.

* A dimple will be left in the centre.



■ Cutting conditions

Drill	VAPDSCBD0800 (φ8)
Workpiece	DIN Ck50
Cutting speed	35m/min
Feed rate	280mm/min
Feed	0.20mm/rev
Pilot drilling	None
Coolant	W.S.O.

FEATURES

Achieves high speed machining

The VAPDSCB delivers longer tool life than a carbide counter boring end mill. Also gives longer tool life than standard HSS tools when high speed machining.

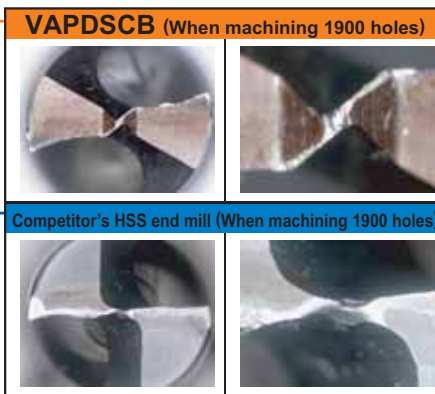
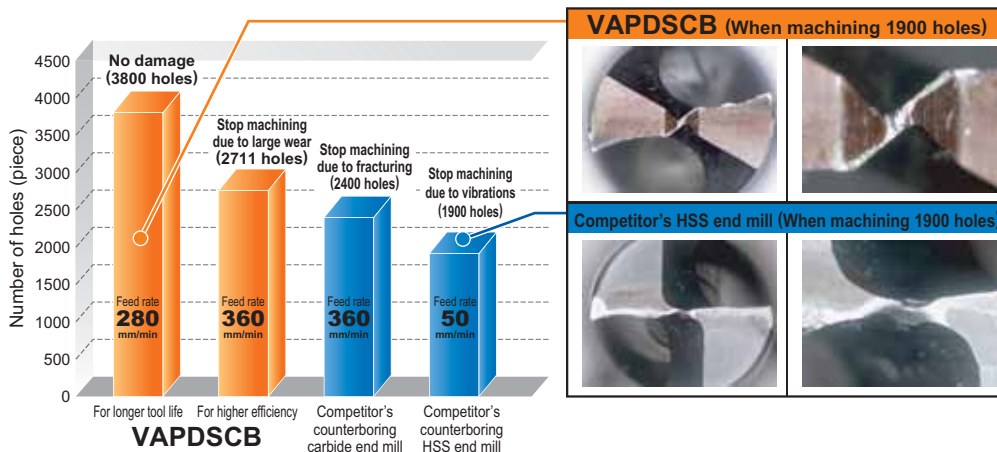

■ Cutting conditions

Drill	VAPDSCBD0800 (φ8)
Workpiece	DIN Ck50
Cutting speed	35m/min (for longer tool life) 45m/min (for higher efficiency)
Feed rate	280mm/min (for longer tool life) 360mm/min (for higher efficiency)
Feed	0.20mm/rev
Pilot drilling	None
Coolant	W.S.O.

P	M	K	S	N	H
✓	✓	✓		✓	

	D1=3	3<D1≤6	6<D1≤10	10<D1≤18	18<D1≤20
D1 Tolerance (mm)	0 -0.014	0 -0.018	0 -0.022	0 -0.027	0 -0.033

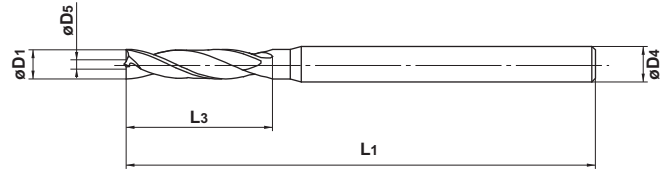

Unit : mm

Order Number	Dia. D1	Dia. (118°) D5	Flute Length L3	Overall Length L1	Shank Dia. D4	Stock
VAPDSCBD0300	3.0	0.8	15	60	3	★
D0350	3.5	0.8	19	70	4	★
D0400	4.0	1.0	21	70	4	★
D0450	4.5	1.0	23	80	6	★
D0500	5.0	1.4	25	80	6	★
D0550	5.5	1.4	27	80	6	★
D0600	6.0	1.4	27	80	6	★
D0650	6.5	1.4	30	80	8	★
D0700	7.0	1.8	32	80	8	★
D0750	7.5	1.8	32	80	8	★
D0800	8.0	2.0	35	85	8	★
D0850	8.5	2.0	35	90	10	★
D0900	9.0	2.8	38	93	10	★
D0950	9.5	2.8	38	93	10	★
D1000	10.0	3.2	41	93	10	★

Order Number	Dia. D1	Dia. (118°) D5	Flute Length L3	Overall Length L1	Shank Dia. D4	Stock
VAPDSCB1050	10.5	3.2	41	101	12	★
D1100	11.0	3.7	45	105	12	★
D1150	11.5	3.7	45	105	12	★
D1200	12.0	3.7	49	109	12	★
D1250	12.5	3.7	49	109	12	★
D1300	13.0	4.2	49	109	12	★
D1350	13.5	4.2	51	121	16	★
D1400	14.0	4.2	51	121	16	★
D1500	15.0	5.5	58	123	16	★
D1600	16.0	5.5	60	125	16	★
D1700	17.0	5.5	62	132	20	★
D1750	17.5	5.5	63	133	20	★
D1800	18.0	6.5	63	133	20	★
D1900	19.0	6.5	65	135	20	★
D2000	20.0	7.5	67	137	20	★

VAPDSCB DRILLS



Ø 3.0~
20.0

● : Stock Standard
 ★ : Stock Standard in Japan.
 □ : Non stock, produced to order only

CUTTING CONDITIONS



Recommended Cutting Conditions

Work Material	Structural steel		Carbon steel Ck55 Alloy steel 070M55 Ductile Cast Iron		Alloy tool steel X210Cr12 (Low-hardness materials) Ferritic stainless steel X10CrA118, X10CrA113 Martensitic stainless steel X20Cr13, X10CrA113		Alloy tool steel W.Nr. 1.2344(H13) (-40HRC) Hardened stainless steel X7CrNiAl177	
	Dia. (mm)	Revolution (min ⁻¹)	Feed rate (mm/rev)	Revolution (min ⁻¹)	Feed rate (mm/rev)	Revolution (min ⁻¹)	Feed rate (mm/rev)	Revolution (min ⁻¹)
3.0	3700	0.10	3200	0.10	2100	0.10	1900	0.05
4.0	2800	0.12	2400	0.12	1600	0.12	1400	0.06
5.0	2200	0.14	1900	0.14	1300	0.14	1150	0.07
6.0	1850	0.15	1600	0.15	1050	0.15	950	0.08
8.0	1400	0.20	1200	0.20	800	0.20	720	0.10
10.0	1100	0.23	960	0.23	640	0.21	570	0.11
12.0	950	0.26	800	0.26	530	0.24	470	0.12
14.0	800	0.27	680	0.27	450	0.25	410	0.13

- The above cutting conditions are for drilling 2xD hole depths without a pilot hole.
When drilling holes smaller than 1xD hole depths, it is possible to increase the RPM by 20%.
- Drilling without a pilot hole is recommended.
If there is a pilot hole, the chips may not be broken. Use a peck feed when chip breaking is necessary.
- For counter boring of a sloped face, a carbide end mill is recommended.
- When machining austenitic stainless steels (X5CrNi1810), reduce the revolutions by 30 - 60% and reduce the feed rate by 40 - 60%.
- Please use a collet type drill chuck.
- Please reduce the revolution and feed rate depending on the drilling situation when the installation of workpiece or machine lacks rigidity.
- Use sufficient cutting fluid.

The above mentioned cutting conditions are a guide when using water soluble cutting fluid.
Please reduce the revolution when using non-water soluble cutting fluid.

VAPDSCB DRILLS

Recommended Cutting Method

The VAPDSCB achieves high efficiency machining without chip jamming.

General cutting method		VAPDSCB cutting method	
<p>① Bolt hole drilling</p>	<p>Chip geometry</p> <p>Good</p>	<p>① Counter boring</p>	<p>Chip geometry</p> <p>Good</p>
<p>② Counter boring</p>	<p>Tangled chips</p>	<p>② Bolt hole drilling</p>	<p>Good</p>

Note) When counter boring using the VAPDSCB, drilling with a pilot hole may produce continuous chips that can wrap around the tool.

DRILLING

CUTTING DATA

Memo

A series of horizontal dashed lines for writing.



MEMO

FORMULAE FOR DRILLING

CUTTING SPEED (vc)

$$v_c = \frac{\pi \cdot D_1 \cdot n}{1000} \text{ (m/min)}$$

v_c (m/min) : Cutting Speed
 π (3.14) : Pi

D_1 (mm) : Drill Diameter
 n (min⁻¹) : Rotational Speed of the Main Spindle

*Unit transformation (from "mm" to "m")

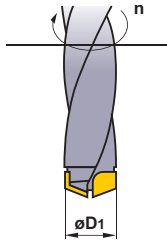

(Problem) What is the cutting speed when the main axis spindle speed is 1350min⁻¹ and drill diameter is 12mm ?

(Answer) Substitute $\pi=3.14$, $D_1=12$, $n=1350$ into the formula

$$v_c = \frac{\pi \cdot D_1 \cdot n}{1000} = \frac{3.14 \times 12 \times 1350}{1000} = 50.9 \text{ m/min}$$

The cutting speed is 50.9m/min.

FEED OF THE MAIN SPINDLE (vf)

$$v_f = f \cdot n \text{ (mm/min)}$$

v_f (mm/min) : Feed Speed of the Main Spindle (Z axis)
 f (mm/rev) : Feed per Revolution
 n (min⁻¹) : Rotational Speed of the Main Spindle

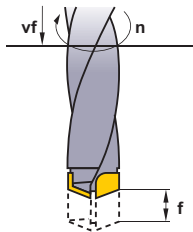

(Problem) What is the spindle feed (vf) when the feed per revolution is 0.2mm/rev and the main axis spindle speed is 1350min⁻¹ ?

(Answer) Substitute $f=0.2$, $n=1350$ into the formula

$$v_f = f \cdot n = 0.2 \times 1350 = 270 \text{ mm/min}$$

The spindle feed is 270mm/min.

DRILLING TIME (Tc)

$$T_c = \frac{l_d \cdot i}{n \cdot f}$$

T_c (min) : Drilling Time
 n (min⁻¹) : Spindle Speed
 l_d (mm) : Hole Depth
 f (mm/rev) : Feed per Revolution
 i : Number of Holes

(Problem) What is the drilling time required for drilling a 30mm length hole in alloy steel at a cutting speed of 50m/min and a feed 0.15mm/rev ?

(Answer) Spindle Speed $n = \frac{50 \times 1000}{15 \times 3.14} = 1061.57 \text{ min}^{-1}$

$$T_c = \frac{30 \times 1}{1061.57 \times 0.15} = 0.188$$

$$= 0.188 \times 60 \approx 11.3 \text{ sec}$$

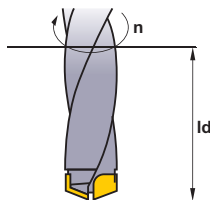

TROUBLE SHOOTING FOR DRILLING

DRILLING

Solution Trouble		Cutting Conditions							Style and Design of the Tool							Machine, Installation of Tool							
		Cutting Speed		Feed	Lower feed at initial cutting	Lower feed when breaking through	Step feed	Coolant			Point Angle	Flank Angle	Back Taper	Land Width	Honing Width	Core Thickness	Body Diameter	Groove Length (Overhang)	Tool installation accuracy	Shorten tool overhang	Flat workpiece face	Workpiece installed securely	Machine Stability, Rigidity
		Up ↗	Down ↘					Increase oil ratio	Increase volume	Increase coolant pressure													
Damage on the Body	● Drill Breakage		●															●		●		●	
	● Abnormal Scratches on the Body		●														●		●				
Damage at Cutting Edge	● Chisel Edge Fracture			●										●						●			
	● Shoulder Fracture				●									●				●					
	● Chipping		●				●							●					●		●		
	● Thermal Crack	●	●					●	●			●	●										
	● Flaking along land						●				●												
	● Abnormal Wear along land	●						●	●									●					
	● Abnormal Wear at Centre	●						●	●														
Chip	● Chip Jamming	●	●			●		●	●							●							
	● Long Chips	●	●					●					●										
	● Chip Discoloration	●						●															
Hole Accuracy	● Large Over Size			●						●				●	●			●					
	● Poor Surface Roughness	●	●	●			●					●	●						●				
	● Poor Roundness	●		●						●	●			●	●			●					
	● Bent, not Vertical			●		●					●	●				●		●	●				
	● Burring		●		●					●			●										
Others	● Chattering, Vibration		●										●						●	●	●	●	
	● Abnormal Noise	●									●	●											

Memo

A series of horizontal dashed lines for writing.

MEMO

DRILLING

